

Z-D22621

KEY NO.	PART NUMBER	DESCRIPTION
	55	SSF-6627 Stud 3/8"-16 both ends (1 used)
	56	CAC-4213 Head assembly (includes valves and screws)
	57	SSF-955 Screw, 3/8"-16 x 1 1/2" (5 used)
	60	SSP-9401 Connector body
✓	61	CAC-291-1 Head gasket
•	62	— Intake flapper valve - square corners (2 used on head)
•	63	— Screw #5-40 x 1/4" (8 used)
	64	CAC-294 Restrictor plate (2 used)
•	65	— Exhaust flapper valve - beveled corners (2 used on valve plate)
	66	CAC-4212-1 Valve plate assembly (includes valves, restrictors and screws)
✓	67	CAC-54-2 Valve plate gasket
✗	68	— Compression ring (2 used)
✗	69	— Compression ring (2 used)
✗	70	— Oil rings and expanders
	71	CAC-55-1 Piston (2 used)
	72	265-19 Piston pin (2 used)
	73	CAC-207 Piston pin plug (4 used)
	74	265-410 Connecting rod assembly (2 used)
	75	SSF-927 Screw, 1/4-20 x 1 1/8" (4 used)
	76	AC-0205 Crankcase and cylinder
	77	SSN-1018 Wavy washer
	78	AC-0169 Oil Seal
	79	SSF-925 Screw, 1/4"-20 x 7/8" (8 used)
	80	DAC-276 Base
✓	81	265-16-1 Base gasket
	82	AC-0203 Crankshaft
	83	SST-104 Ball bearing (2 used)
	84	SSP-486 Pipe plug (2 used)
	85	SSP-505 Oil plug
	86	265-2 Flywheel
	87	SSN-1014-ZN Belleville washer
	88	SSF-3039-ZN Cap screw
	90	265-6 Vent Filter (2 used)

NOT SHOWN

265-17	Filter
265-18	Retaining Filter
SSF-935	Screws

- ✗ Available as part of Ring Kit KK-4313.
- ✓ Available as part of Gasket Kit K-0159.
- Available in Valve Kit KK-4275.

KeyNo.	Torque
55	25 to 30 Ft. Lbs.
57	25 to 30 Ft. Lbs.
63	13 to 17 In. Lbs.
75	7 to 10 Ft. Lbs.
79	9 to 12 Ft. Lbs.
88	15 to 20 Ft. Lbs.

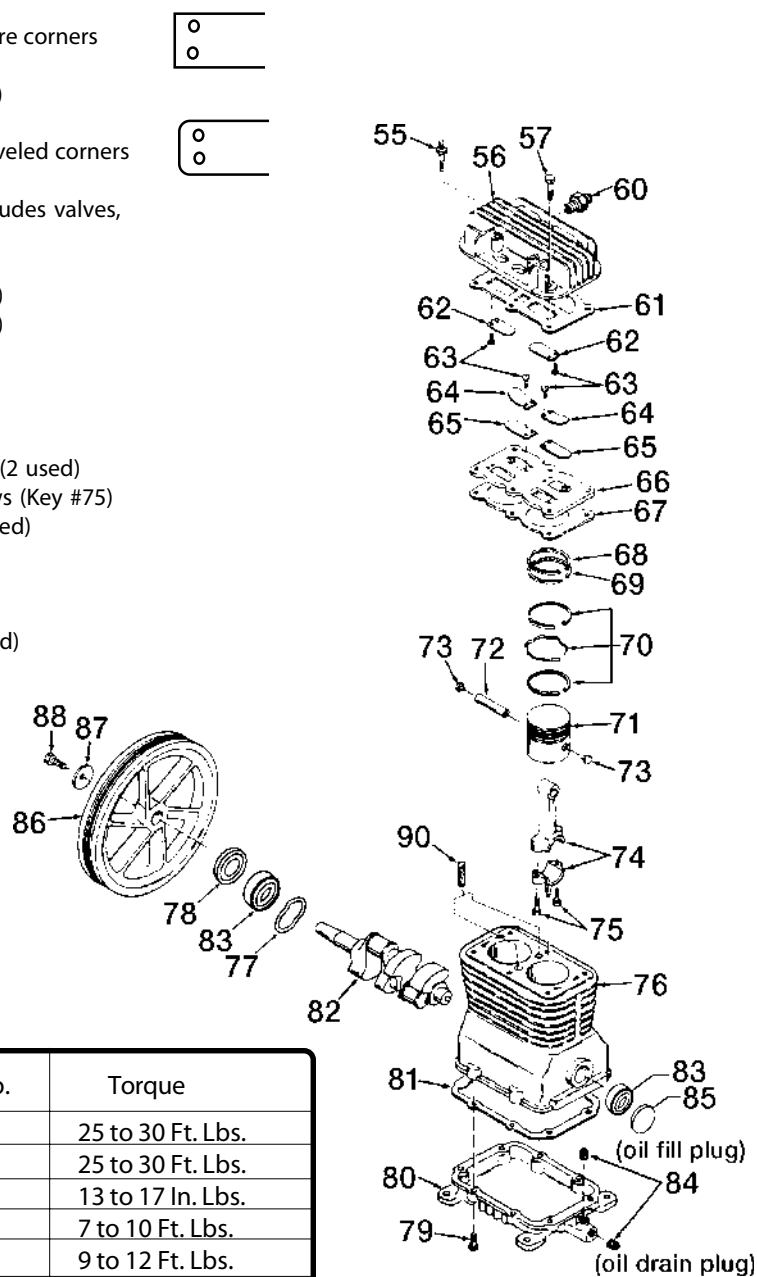

Recommended Oils - One Stage Compressor Units
 Use a compressor oil such as SAE 20-20W SF motor oil. (Crankcase oil capacity is 16 fluid ounces.) Under extreme winter conditions use 10 weight oil. Multiviscosity oil, 10W30, will leave carbon deposits on critical components, reducing performance and compressor life.