

XC2800

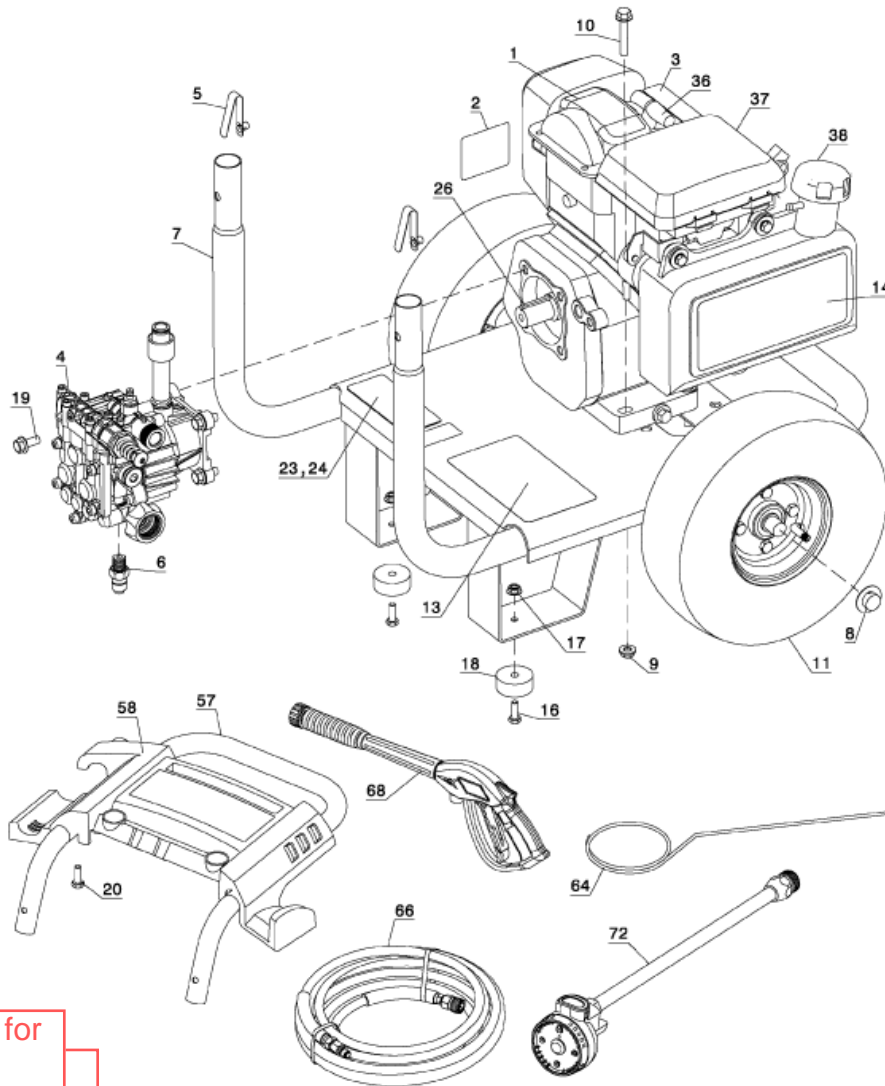

Click highlighted text for Pump Breakdown

Item #	Part #	Description	Qty	Item #	Part #	Description	Qty
2	D23124	LABEL,WARNING	1	19	A06113	SCREW	4
3	A16263	DECAL	1	20	A01519	SCREW .250-10 X .75	2
4	A20102	PUMP ASSEMBLY	1	23	A20138	NAMEPLATE	1
5	D30492	BUTTON SNAP .302 DIA	2	24	A16264	PROTECTION CAP	1
6	17658	VALVE THERMAL RELIEF	1	26	P448	KEY	1
7	A20144	FRAME	1	36	285800-98	SPARK PLUG	1
8	F464	NUT .625 PAL PRESS W	2	37	A07041	FILTER HONDA	1
9	16087	NUT .313-18 UNC FLAN	4	38	285807-50	FUEL CAP	1
10	18297	BOLT .313-18X1.75 FL	4	57	A20161	HANDLE	1
11	A14448	TIRE PNEU 10	2	58	A20194	PANEL	1
13	A16034	DECAL	1	64	NCT001	TOOL NOZZLE CLEANING	1
14	A16035	DECAL	1	66	A20246	HOSE	1
16	D21436	SCREW .250-20X.750 U	2	68	A09154	GUN	1
17	D21437	NUT.250-20 FLANGEHEA	2	72	A20038	GUN	1
18	D22268	ISOLATOR RECESSED RU	2	109	5140046-92	VENT KIT	1

Use Mobil 15 W50 Synthetic Oil in your pump.