



9.956.028 R00

584 PROFLAME Instruction Book Collection



584 PROFLAME ELITE System

4 - 17

584 PROFLAME PLUS System

18 - 29

584 PROFLAME System

30 - 39

Appendix: DIP SWITCH NUMBER (0=ON 1=OFF)

40 - 41

584 PROFLAME ELITE System

4 - 17



Fig. 1

The SIT 584 PROFLAME ELITE System is a device that allows, in conjunction with the Combination Gas Control, to command appliances like fireplaces and logs.

With the Remote Control it is possible to turn the gas fireplace on and off, increase or decrease the flame height manually or select among three pre-programmed flame patterns, use a timer to shut down the fireplace automatically. Room thermostat and Backup functions are included. Auxiliary device and fan can also be controlled.

The 584 PROFLAME ELITE System consists of the 584 PROFLAME ELITE Transmitter, the 584 PROFLAME Line Receiver and the necessary harness to connect the Receiver to the Gas Valve; see Fig. 1.

The 584 PROFLAME ELITE System is designed to only command the 820 NOVA mV converted with the STEP MOTOR modulating kit or the 825 NOVA PROFLAME Combination Gas Control; see Fig. 2.

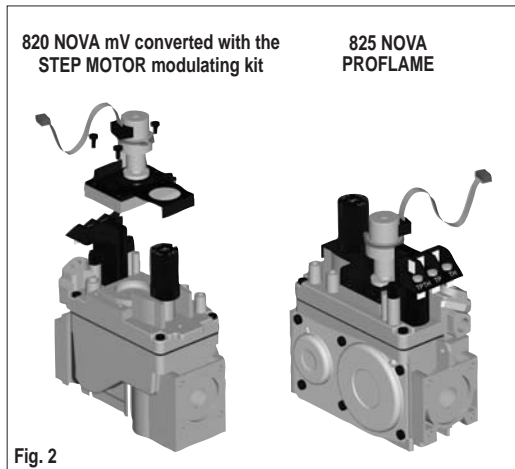

Fig. 2

TECHNICAL DATA

Remote Control

Supply voltage	4.5 V (three 1.5 V AAA batteries)
Ambient temperature ratings	0 - 60 °C (32 - 140 °F)
Number addresses	128
Radio frequency	433.92 MHz
Set temperature range	0 - 37 °C (32 - 99 °F)

Receiver

Supply voltage / frequency	115 V / 60 Hz
Power:	
Without fan	10 VA
With fan	160 VA
Internal fuse	5x20 mm 250 Vac 2 A Fast
Fan (voltage / frequency / current)	115 V / 60 Hz / 1.5 A maximum
Ambient temperature ratings	0 - 60 °C (32 - 140 °F)
Number addresses	128
Radio frequency	433.92 MHz
Auxiliary output:	
Voltage	120 Vac maximum
Current	2 A maximum
Power factor	> 0.8

FCC NOTICE

This equipment has been tested and found to comply with the limits for a Class B digital device, pursuant to Part 15 of FCC Rules. These limits are designed to provide reasonable protection against harmful interference in a residential installation.

This equipment generates, uses and can radiate radio frequency energy and, if not installed and used in accordance with the instructions, may cause harmful interference to radio communications. However, this is no guarantee that interference will not occur in a particular installation.

If this equipment does cause harmful interference to radio or television reception, which can be determined by turning the equipment off and on, the user is encouraged to try to correct the interference by one or more the following measures:

- Reorient or relocate the receiving antenna.
- Increase the separation between the equipment and Receiver.
- Connect the equipment into an outlet on a circuit different from that to which the Receiver is connected.
- Consult the dealer or an experienced radio/TV technician for help.

INSTALLATION

Installation of the Receiver

The Receiver must be screwed up to the appliance using the holes that are present on two sides of the Receiver, see Fig. 3. The mounting hardware is not supplied.

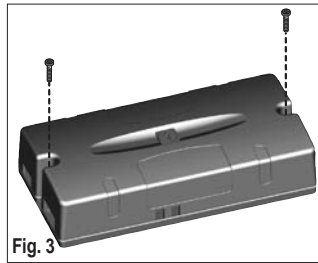

Fig. 3

Automatic / Manual selection

Set the BACKUP switch to AUTO position; see Fig. 4.



Fig. 4: BACKUP switch

Step Motor connection

Connect the step motor cable of the gas valve to the proper connector of the Receiver; see Fig. 5.



Fig. 5: Step Motor connector

Thermopile connection

Connect the "+" (positive) terminal of the thermopile to the TP terminal of the gas valve. Connect the "-" (negative) terminal of the thermopile to the TPTH terminal of the gas valve; see Fig. 6.

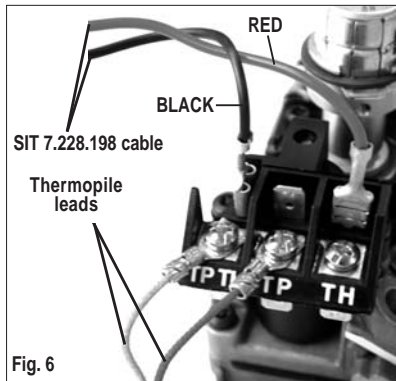

Fig. 6

Connection of the Receiver to the gas valve

Connect the SIT 7.228.198 cable (supplied with the package) to the receiver GAS VALVE connector; see Fig. 7.

Then the red wire must be connected to the TH terminal of the gas valve while the black wire must be connected to the TPTH terminal of the gas valve; see Fig. 6.

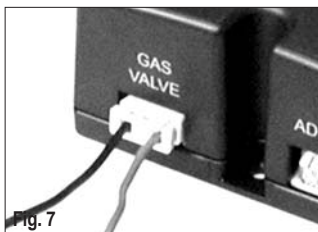

Fig. 7

Receiver setting address

Select, with the proper dip-switches, the address of the Receiver; see Fig. 8. See table in the



Fig. 8

Appendix for the proper setting of the switches to select a particular address number. Switch #8 must always be in ON position (down).

Fan Connection

Connect the fan of the appliance (if present) to the socket on the Receiver. It must be used a NEMA15 plug; see Fig. 9. The cable to connect the fan to the Receiver is not supplied.



Fig. 9

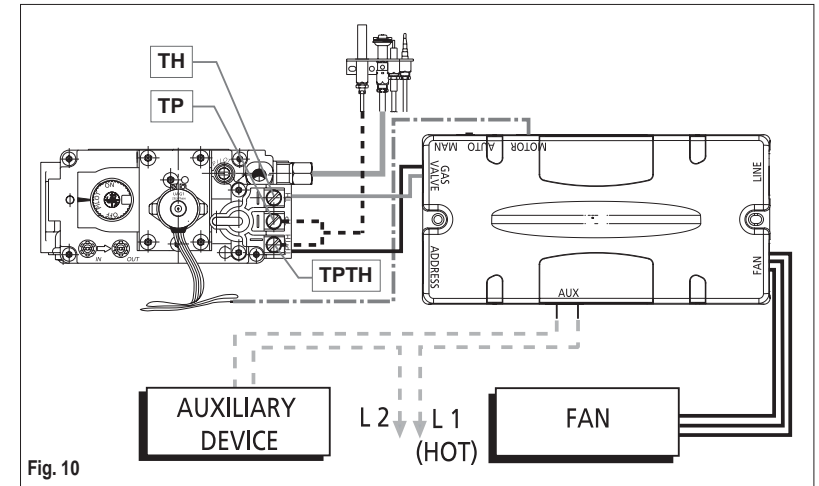

Fig. 10

Auxiliary device connection

An auxiliary device can be turned on and off by the Remote Control; connect it to the Receiver as per Fig. 10. Two 1/4 in. spade terminals are required for the connection; see Fig. 11.

Check voltage and current required by the auxiliary device; they shall be 120 V, 50/60 Hz, 1.5 A maximum.



Fig. 11

Receiver power

Connect the power cable (not supplied) to the plug on the Receiver and to the power socket; see Fig. 12. Use a CEE22 cable for the Receiver side.

At this time the Receiver is powered and after few seconds, needed to perform the calibration of the step motor, an acoustic signal is generated to indicate the ready state of the Receiver.



Fig. 12

SYSTEM CONTROL OPERATION

Preliminary check of the Receiver

Operations to be done, before switching on the Remote Control:

- Check that the electrical connections are in accordance with Fig. 10.
- Connect the cable to the power plug of the Receiver and wait for the generation of the acoustic signal ("beep") as a confirmation that the Receiver is working; see Fig. 12.
- Check that the BACKUP switch is in AUTO position (to the left) to let the Remote Control operate the gas valve; see Fig. 4.

Note: All the above operations can be done without turning on the pilot flame in the appliance.

Check the functionality of the Remote Control

The Remote Control is powered by three 1.5 V AAA batteries. When the batteries are installed into the proper compartment (see Fig. 13), the icon "little house" with the measurement of the room temperature will be shown by the display; see Fig. 14. This indication will always be present when the Remote Control has battery power.

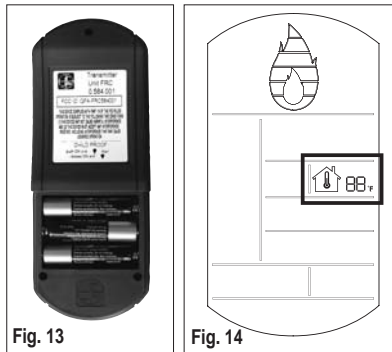

Fig. 13

Fig. 14

Check the communication between the Remote Control and the Receiver

When the ON/OFF key is pressed to switch on the Remote Control, the "transmission" icon is activated to indicate the transmission of a command to the Receiver; see Fig. 15 and Fig. 16. Other icons will become visible on the LCD display. This indicates that the Remote Control is switched on.

At the same time the Receiver will generate an acoustic signal to indicate the reception of the command. If the acoustic signal isn't generated switch the Remote Control off, move at a lower

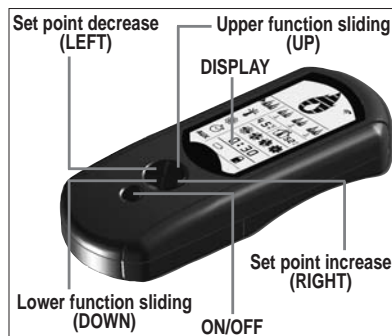

Fig. 15: 584 PROFLAME ELITE Transmitter

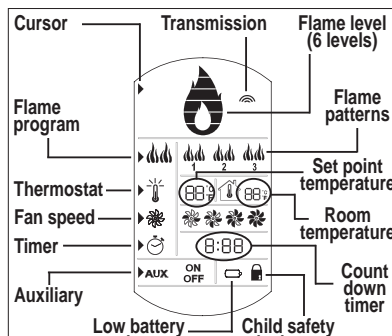

Fig. 16: Remote Control Display

distance from the Receiver and switch the Remote Control on again.

If again the acoustic signal is not generated it is necessary to execute the address setting procedure described below.

Address setting procedure

Use the UP or DOWN key on the Transmitter until the cursor (small triangle) is left of the clock icon, see Fig. 17. From time 0:00 press the LEFT key ten times. The display will show then the transmitter address, see Fig. 18. Press the LEFT key to exit this function.

The transmitter address is required to be equal to the Receiver. Select, through setting of the dip switches, the address of the Receiver. See the table in the Appendix for the proper setting of the switches. Switch #8 must always be in the ON position (down).

It is also possible to start a receiver address search sequence through the Transmitter. To enter this function use the DOWN or UP keys until the cursor (small triangle) is left of the clock icon, see Fig. 17. From time 0:00 press the LEFT key ten times. The display will then show the present transmitter address (see Fig. 18). To alter the address of the Transmitter press the UP key to increase and DOWN key to decrease it.

A "beep" from the Receiver will confirm the same address as the Transmitter. Press LEFT key to exit this function.

Note: The address of the Receiver is acquired only at its power on. Changing the address while the Receiver is powered will not have any effect. To change the address of the Receiver, disconnect the power cable from the Receiver, change the address and reconnect the power cable to the Receiver.

Fahrenheit - Celsius temperature indication

It is possible to set the Remote Control to display the temperatures in either Fahrenheit or Celsius.

Use the UP or DOWN key on the Transmitter until the cursor (small triangle) is left of the clock icon, see Fig. 17. From time 0:00 press the LEFT key ten times. The display will show the transmitter address, see Fig. 18. Use the RIGHT key to toggle from °F to °C and vice versa. The display will show the selected unit of measure, see Fig. 19 and Fig. 20.

Press the LEFT key to exit this function.

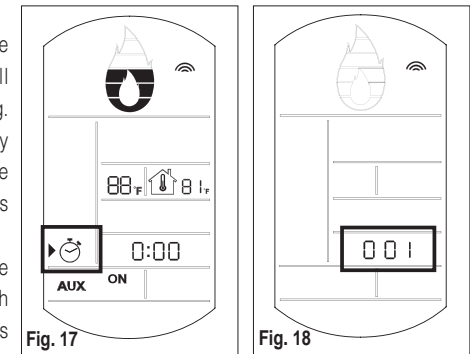

Fig. 17

Fig. 18

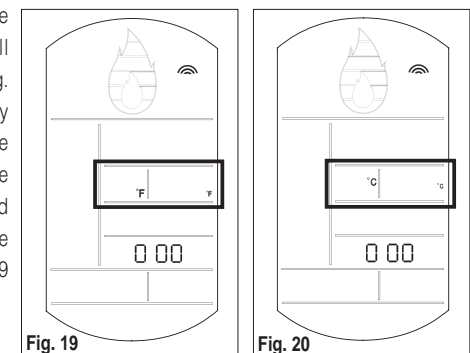

Fig. 19

Fig. 20

VALVE OPERATION

WARNING**Fire or Explosion Hazard. Can cause damage to property and severe injury or death.**

Do not force the control knob. Use only your hand to turn the knob. If the knob does not move by hand, the valve should be replaced by a trained service technician.

Set the Remote Control OFF. Press slightly and turn the control knob clockwise to the "OFF" position and wait five minutes; thus allowing any gases to escape which may have accumulated in the combustion chamber.

Note: LP gases do not vent upward.

**Pilot flame ignition**

Press slightly and rotate the control knob to the "PILOT" position. Press the knob and light the pilot flame, keeping the knob fully depressed for at least thirty (30) seconds until air in the pilot line vents and a strong pilot flame is present. Release the knob and verify that the pilot flame remains lit.

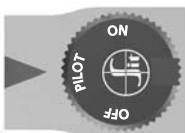
**Igniting the main burner**

Turn the control knob to the "ON" position. With the knob in this position the gas valve is ready to be operated by the Receiver.

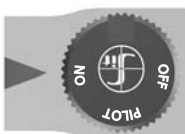
**Pilot position**

To maintain flame to the pilot burner with the main burner off, turn the control knob to the "PILOT" position.

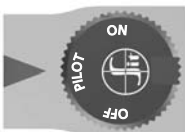
**Turning off**

Turn the control knob to the "OFF" position to switch OFF both main and pilot burner.

**CAUTION**

After shutting off, wait at least five minutes before re-igniting. This will allow the safety interlock to reset.

OPERATING PROCEDURES

Note: To operate the appliance with the Remote Control, it is necessary that the pilot flame is turned on and that the thermopile is hot enough to supply the power required by the gas valve. Furthermore the gas valve operating knob is required to be in the ON position.

Note: The Receiver has a temporary memory to store the commands sent by the Remote Control. When a command is received, an acoustic signal is generated to confirm the reception of the command and the command is stored. The command will be executed as soon as allowed by the control logic of the Receiver.

For instance an "ON" command sent immediately after the appliance has been turned off will be only executed after that the step motor modulator has returned to its maximum flame height position.

In the same way a command to set the flame level sent just after the appliance has been turned on will be executed only after the 5 second main burner ignition time at maximum flame height has elapsed.

With reference to the four keys arranged in a circle (see Fig. 15), the upper and lower keys (scrolling) allow the selection of the functions included in the Remote Control. The left and right keys (increase and decrease of the set points) allow modification of the working levels/states of the selected function.

The single push button is used to turn the appliance on and off.

The Remote Control will transmit when a key is pressed and the time of each transmission selection will not be longer than one second.

Turn on the appliance

If the appliance and the Remote Control are switched off, the icon "little house" with the measurement of the room temperature is shown on the LDC display; see Fig. 14. When the ON/OFF key is pressed, the other icons will become visible on the LCD display. This indicates that the Remote Control is switched on. At the same time the Receiver connects the power of the thermopile to the gas valve millivolt coil and the appliance main burner turns on. An acoustic signal from the Receiver confirms the reception of the command.

Note: Upon turning the Transmitter to on be aware that the system holds the flame height to the maximum value for 5 seconds to allow a proper ignition of the burner. Attempts to increase or decrease the flame height during this period will be ignored.

Turn off the appliance

If the appliance and the Remote Control are switched on, when the ON/OFF key is pressed, the Remote control is turned off. At the same time the Receiver removes power from the gas valve millivolt coil and the appliance main burner turns off. An acoustic signal from the Receiver confirms the reception of the command.

Note: Upon turning the Transmitter to off, the system will drive the step motor modulator to the maximum flame height position, preparing the system for the next ignition. Therefore if during this time an "ON" command is sent, it will be executed once the step motor modulator has reached the maximum flame height position.

Flame height

This function allows remote control of the flame height.

Check that the Remote Control is on, otherwise, turn on the Remote Control and wait 5 seconds.

Select the manual flame height function using the UP or DOWN key until the cursor (small triangle) is to the left of the big flame (see Fig. 21). Use the RIGHT or LEFT key to set the desired flame height. Six flame levels are included, from 1 (minimum) to 6 (maximum), see Fig. 22. An acoustic signal from the Receiver confirms the reception of the command.

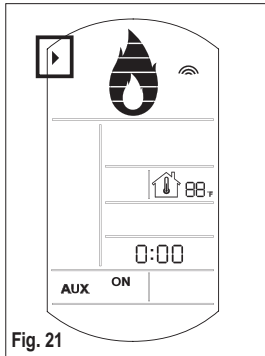

Fig. 21

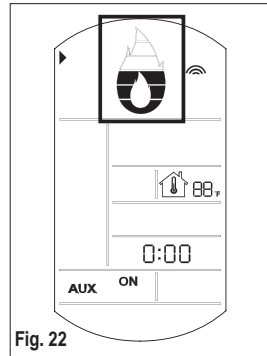

Fig. 22

Automatic change of the flame height

The system is provided with three automatic sequences to change continuously the flame height. Thirty steps compose each sequence with an interval between one step and the other of 5 seconds, for a total duration of 2.5 minutes; see Fig. 23. At the end the sequence repeats continually until the sequence function is changed to an alternate pattern or turned off.

The Remote Control can select one of the predefined sequences. Use the UP or DOWN until the cursor (small triangle) is to the left of the two small flames; see Fig. 24.

Use the LEFT or RIGHT key to select sequence 1, 2 or 3; see Fig. 25.

When using the sequence function the room thermostat is active.

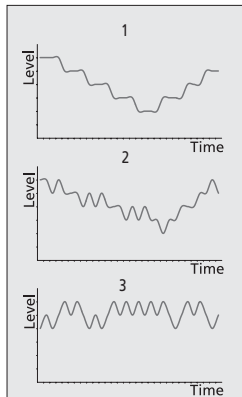

Fig. 23: Flame patterns

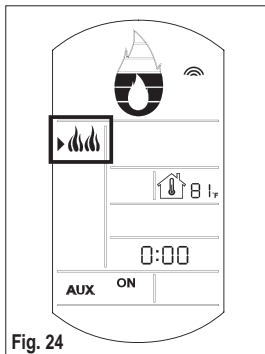

Fig. 24

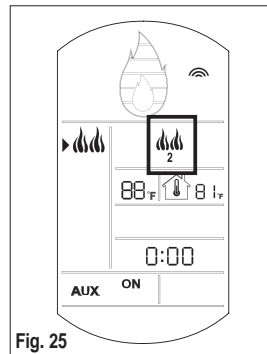

Fig. 25

Room thermostat

The Remote Control can operate as a room thermostat.

To activate this function use the UP or DOWN key until the cursor (small triangle) is left of the thermometer icon, see Fig. 26.

Then use the RIGHT or LEFT key to set the desired room temperature, see Fig. 27.

The control system will cycle automatically the appliance on or off to maintain the selected temperature.

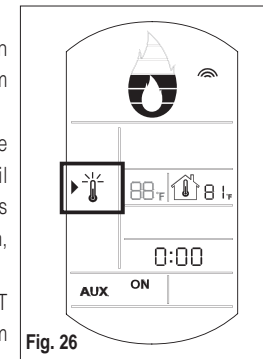

Fig. 26

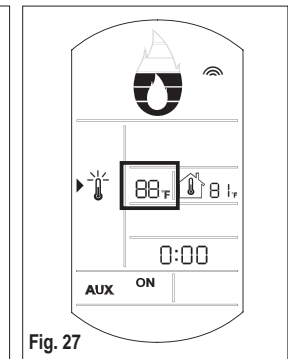

Fig. 27

Fan speed setting

This function controls the speed of the hot air circulating fan if the appliance is provided with a fan. The fan speed can be set to one of 4 levels included or turned off (level 4 means full speed).

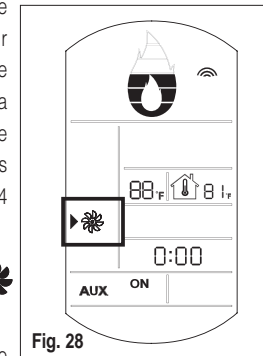

Fig. 28

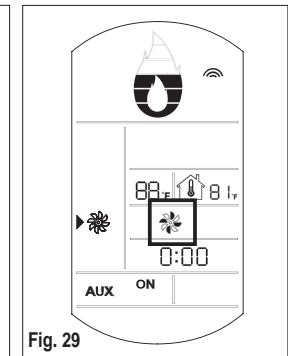

Fig. 29

To set the fan speed use the UP or DOWN key until the cursor (small triangle) on the left will be near the fan icon; see Fig. 28.

Then use the LEFT or RIGHT key to set the desired fan speeds; see Fig. 29. An acoustic signal is generated to confirm the reception of the command.

Timer setting

The Remote Control has a sleep function. With this function it is possible to set a sleep time. After this time has elapsed the appliance is automatically switched off.

To activate the function use the UP or DOWN key until the cursor (small triangle) is to the left of the clock icon, see Fig. 30.

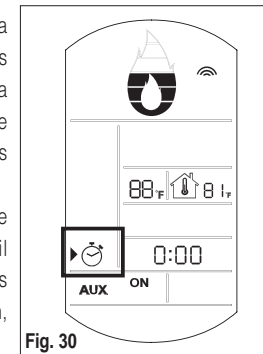

Fig. 30

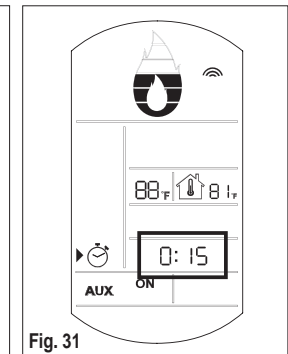

Fig. 31

Then use the RIGHT or LEFT key to set the desired sleep time, see Fig. 31.
It is possible to set a maximum time of 90 minutes with 15 minutes steps.
After the desired time has been set press the UP or DOWN key to start the timer.

Auxiliary output

The auxiliary function allows switching of one additional electrical accessory on and off. The connection of the auxiliary device shall be made as per Fig. 10.
To control the auxiliary device use the UP or DOWN key until the cursor (small triangle) is to the left of the AUX word; see Fig. 32.
Then use the RIGHT key to operate the device (see Fig. 33) or LEFT key to disconnect it (see Fig. 34).
An acoustic signal is generated to confirm the reception of the command.

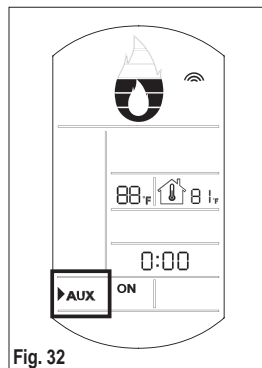

Fig. 32

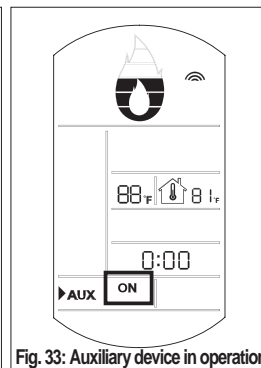

Fig. 33: Auxiliary device in operation

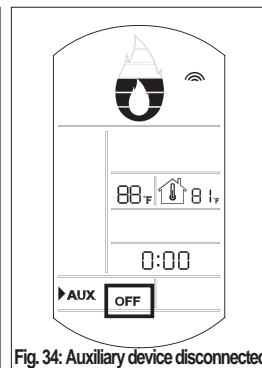

Fig. 34: Auxiliary device disconnected

Child safety lock-out

This function is to deactivate the remote control keys. The function is active when the lock icon is lit, see Fig. 35.
To activate this function press the ON/OFF key and within one second the UP key.
To reactivate the remote control keys follow the same sequence, press ON/OFF key and within one second press the UP key.

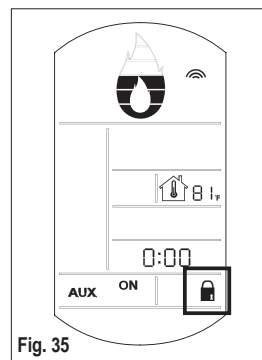

Fig. 35

Power failure

During main power loss it is not possible to turn on the appliance with the Remote Control. It is possible to turn the appliance on manually using the Backup switch of the Receiver set to the MAN position.
When set to MAN, the power of the thermopile is connected to the gas valve coil allowing ignition of the main burner of the appliance.

Note: On subsequent restoration of the main power and with the BACKUP switch in AUTO position, the Receiver leaves the appliance turned off even if the Remote Control is turned on. In this case, to switch on the appliance, press the ON/OFF button of the Remote Control twice.

Low battery detection

The duration of the batteries depends on many factors: the quality of the batteries used, the number of ignitions of the appliance, the number of changes to the flame height, etc.
When the transmitter batteries are low, an icon will be displayed on the LCD display (see Fig. 36) to alert of a low battery condition before losing battery power at all. As soon as the depleted batteries are replaced, the Transmitter will restart its normal operation.

Timeout

If the appliance is turned on and the Receiver does not receive any command for 24 hours, it automatically turns the appliance and the Remote Control off.

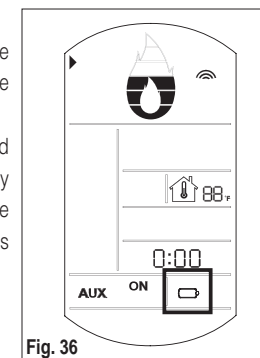

Fig. 36

WARNINGS AND CAUTIONS

WARNING

Fire Hazard. Can cause severe injury or death

The Receiver causes the ignition of the fireplace. The fireplace can turn on suddenly. Keep away from the burner, especially when operating on the BACKUP switch.

WARNING

Shock Hazard. Can cause severe injury or death

This device is powered with line voltage. Do not try to repair this device
No service need to be made on the internal components. The box must be opened only after the disconnection of the power cable and in any case only by specialized trained personnel.

CAUTION

Property Damage Hazard.

Excessive heat can cause property damage

The fireplace can stay ignited for many hours. Take care to turn off the fireplace if it is unattended by adult people.
Do not leave the Remote Control where children can reach it.

DIMENSIONAL DRAWINGS

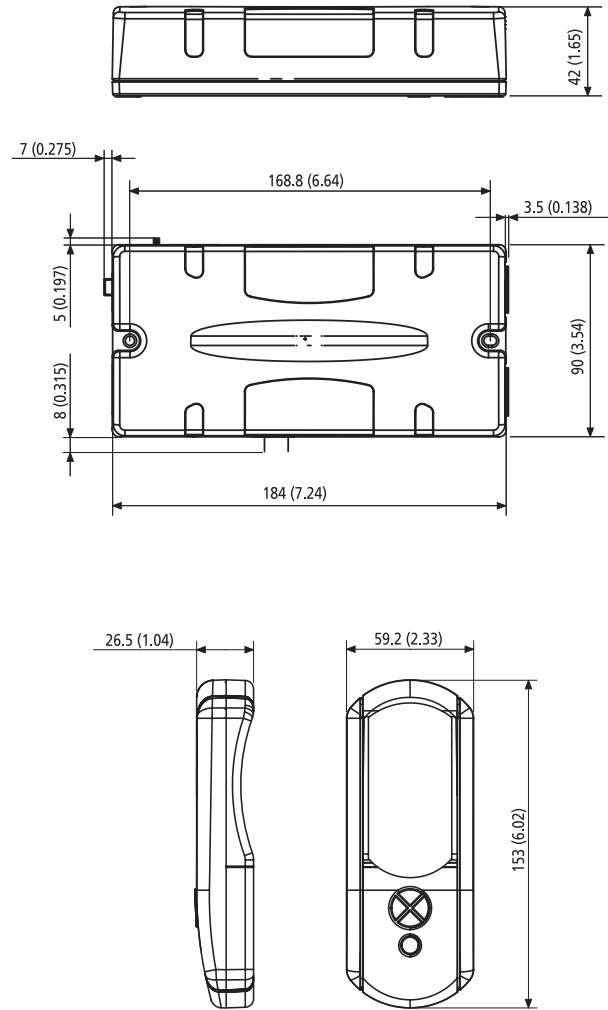

NOTE: All the dimensions are expressed in millimeters (inches).



Fig. 1

The SIT 584 PROFLAME PLUS System is a device that allows, in conjunction with the Combination Gas Control, to command appliances like fireplaces and logs.

With the Remote Control it is possible to turn the gas fireplace on and off, increase or decrease the flame height and use a timer to shut down the fireplace automatically. Room thermostat and Backup functions are also included.

The 584 PROFLAME PLUS System consists of the 584 PROFLAME PLUS Transmitter, the 584 PROFLAME Battery Receiver and the necessary harness to connect the Receiver to the Gas Valve; see Fig. 1.

The 584 PROFLAME PLUS System is designed to only command the 820 NOVA mV converted with the STEP MOTOR modulating kit or the 825 NOVA PROFLAME Combination Gas Control; see Fig. 2.

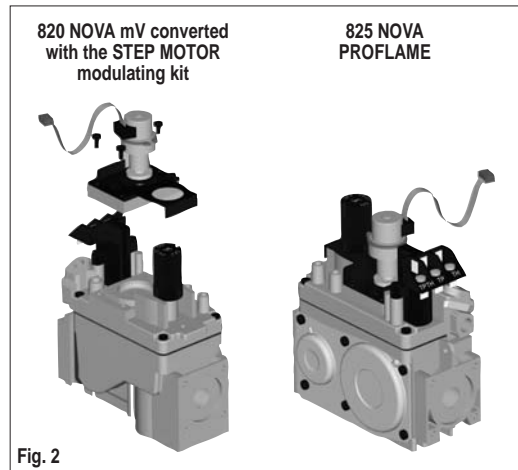

Fig. 2

TECHNICAL DATA

Remote Control

Supply voltage	4.5 V (three 1.5 V AAA batteries)
Ambient temperature ratings	0 - 60 °C (32 - 140 °F)
Number addresses	128
Radio frequency	433.92 MHz
Set temperature range	0 - 37 °C (32 - 99 °F)

Receiver

Supply voltage	6 V (four 1.5 V AA batteries)
Ambient temperature ratings	0 - 60 °C (32 - 140 °F)
Number addresses	128
Radio frequency	433.92 MHz

WARNING

Fire Hazard. Can cause severe injury or death

The Receiver causes the ignition of the fireplace. The fireplace can turn on suddenly. Keep away from the burner, especially when operating on the BACKUP switch.

CAUTION

Property Damage Hazard.

Excessive heat can cause property damage

The fireplace can stay ignited for many hours. Take care to turn off the fireplace if it is unattended by adult people.

Do not leave the Remote Control where children can reach it.

FCC NOTICE

This equipment has been tested and found to comply with the limits for a Class B digital device, pursuant to Part 15 of FCC Rules. These limits are designed to provide reasonable protection against harmful interference in a residential installation.

This equipment generates, uses and can radiate radio frequency energy and, if not installed and used in accordance with the instructions, may cause harmful interference to radio communications. However, this is no guarantee that interference will not occur in a particular installation.

If this equipment does cause harmful interference to radio or television reception, which can be determined by turning the equipment off and on, the user is encouraged to try to correct the interference by one or more the following measures:

- Reorient or relocate the receiving antenna.
- Increase the separation between the equipment and Receiver.
- Connect the equipment into an outlet on a circuit different from that to which the Receiver is connected.
- Consult the dealer or an experienced radio/TV technician for help.

INSTALLATION

Installation of the Receiver

The Receiver must be screwed up to the appliance using the holes that are present on two sides of the Receiver, see Fig. 3. The mounting hardware is not supplied.

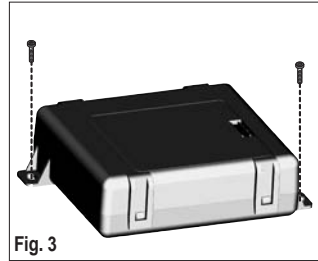

Fig. 3

Automatic / Manual Selection

Set the BACKUP switch to AUTO position; see Fig. 4.



Fig. 4: BACKUP switch

Step Motor connection

Connect the step motor cable of the gas valve to the proper connector of the Receiver; see Fig. 5.



Fig. 5: Step Motor connector

Thermopile connection

Connect the "+" (positive) terminal of the thermopile to the TP terminal of the gas valve. Connect the "-" (negative) terminal of the thermopile to the TPTH terminal of the gas valve; see Fig. 6.

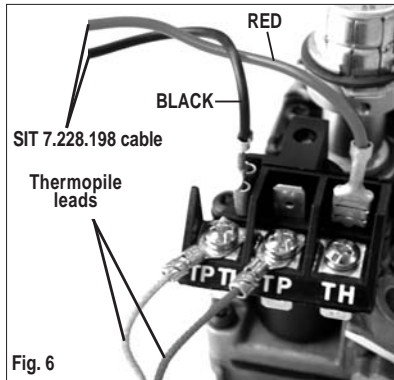

Fig. 6

Connection of the Receiver to the gas valve

Connect the SIT 7.228.198 cable (supplied with the package) to the receiver GAS VALVE connector; see Fig. 7. Then the red wire must be connected to the TH terminal of the gas valve while the black wire must be connected to the TPTH terminal of the gas valve; see Fig. 6.



Fig. 7



Fig. 8

Receiver setting address

Select, with the proper dip-switches, the address of the Receiver, see Fig. 8. See table in the Appendix for the proper setting of the

switches to select a particular address number. Switch #8 must always be in ON position (down).

Batteries installation

Insert in the proper compartment four 1.5 V AA type batteries. Do not reverse the polarity of the batteries; see Fig. 9.



Fig. 9

At this time the Receiver is powered and after few seconds, needed to perform the step motor calibration, a short sound will be generated to indicate that the device is ready to receive commands from the Remote Control.

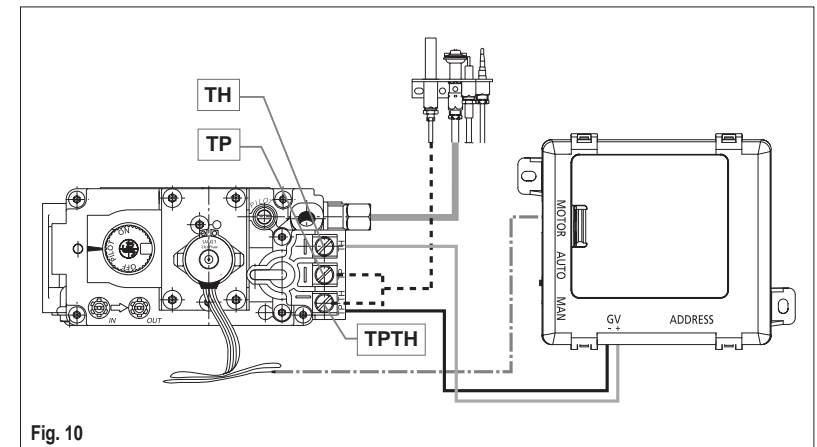

Fig. 10

SYSTEM CONTROL OPERATION

Preliminary check of the Receiver

Operations to be done, before switching on the Remote Control:

- Check that the electrical connections are in accordance with Fig. 10.
- Insert the batteries (4 x 1.5 V AA style) in the proper compartment and wait for the generation of the acoustic signal ("beep") as a confirmation that the Receiver is working; see Fig. 9.
- Check that the BACKUP switch is in AUTO position (to the left) to let the Remote Control operate the gas valve; see Fig. 4.

Note: All the above operations can be done without turning on the pilot flame in the appliance.

Check the functionality of the Remote Control

The Remote Control is powered by three 1.5 V AAA batteries. When the batteries are installed into the proper compartment (see Fig. 11), the icon "little house" with the measurement of the room temperature will be shown by the display; see Fig. 12. This indication will always be present when the Remote Control has battery power.

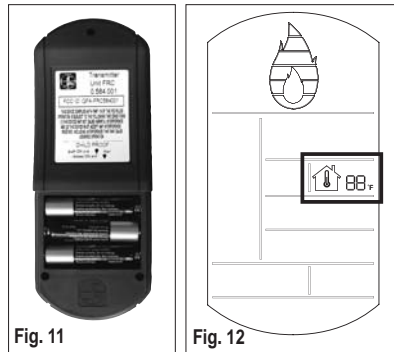

Fig. 11

Fig. 12

Check the communication between the Remote Control and the Receiver

When the ON/OFF key is pressed to switch on the Remote Control, the "transmission" icon is activated to indicate the transmission of a command to the Receiver; see Fig. 13 and Fig. 14. Other icons will become visible on the LCD display. This indicates that the Remote Control is switched on.

At the same time the Receiver will generate an acoustic signal to indicate the reception of the command.

If the acoustic signal isn't generated switch the Remote Control off, move at a lower distance from

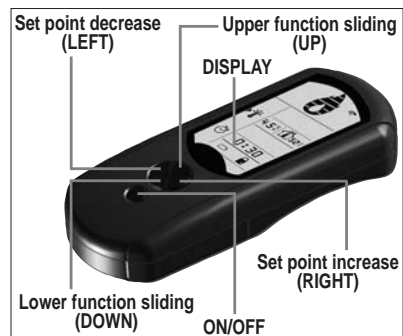

Fig. 13: 584 PROFLAME PLUS Transmitter

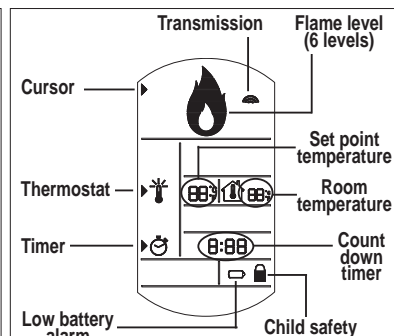

Fig. 14: Remote Control Display

the Receiver and switch the Remote Control on again.

If again the acoustic signal is not generated it is necessary to execute the address setting procedure described below.

Address setting procedure

Use the UP or DOWN key on the Transmitter until the cursor (small triangle) is left of the clock icon, see Fig. 15. From time 0:00 press the LEFT key ten times. The display will show then the transmitter address, see Fig. 16. Press the LEFT key to exit this function.

The transmitter address is required to be equal to the Receiver. Select, through setting of the dip switches, the address of the Receiver. See the table in the Appendix for the proper setting of the switches. Switch #8 must always be in the ON position (down).

It is also possible to start a receiver address search sequence through the Transmitter. To enter this function use the DOWN or UP keys until the cursor (small triangle) is left of the clock icon, see Fig. 15. From time 0:00 press the LEFT key ten times. The display will then show the present transmitter address (see Fig. 16). To alter the address of the Transmitter press the UP key to increase and DOWN key to decrease it.

A "beep" from the Receiver will confirm the same address as the Transmitter. Press LEFT key to exit this function.

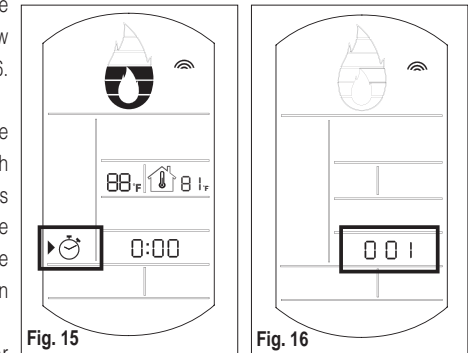

Fig. 15

Fig. 16

Note: The address of the Receiver is acquired only at its power on. Changing the address while the Receiver is powered will not have any effect. To change the address of the Receiver, disconnect the batteries from the Receiver, change the address and reconnect the batteries again.

Fahrenheit - Celsius temperature indication

It is possible to set the Remote Control to display the temperatures in either Fahrenheit or Celsius.

Use the UP or DOWN key on the Transmitter until the cursor (small triangle) is left of the clock icon, see Fig. 15. From time 0:00 press the LEFT key ten times. The display will show the transmitter address, see Fig. 16. Use the RIGHT key to toggle from °F to °C and vice versa. The display will show the selected unit of measure, see Fig. 17 and Fig. 18.

Press the LEFT key to exit this function.

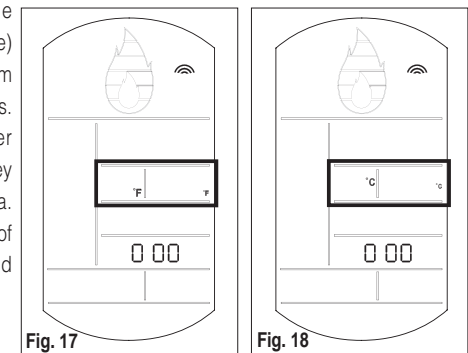

Fig. 17

Fig. 18

VALVE OPERATION

WARNING**Fire or Explosion Hazard. Can cause damage to property and severe injury or death.**

Do not force the control knob. Use only your hand to turn the knob. If the knob does not move by hand, the valve should be replaced by a trained service technician.

Set the Remote Control OFF. Press slightly and turn the control knob clockwise to the "OFF" position and wait five minutes; thus allowing any gases to escape which may have accumulated in the combustion chamber.

Note: LP gases do not vent upward.

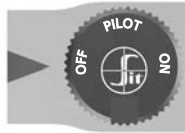
**Pilot flame ignition**

Press slightly and rotate the control knob to the "PILOT" position. Press the knob and light the pilot flame, keeping the knob fully depressed for at least thirty (30) seconds until air in the pilot line vents and a strong pilot flame is present. Release the knob and verify that the pilot flame remains lit.

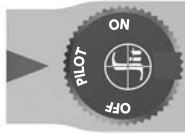
**Igniting the main burner**

Turn the control knob to the "ON" position. With the knob in this position the gas valve is ready to be operated by the Receiver.

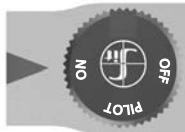
**Pilot position**

To maintain flame to the pilot burner with the main burner off, turn the control knob to the "PILOT" position.

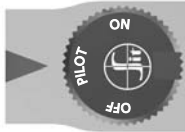
**Turning off**

Turn the control knob to the "OFF" position to switch OFF both main and pilot burner.

**CAUTION**

After shutting off, wait at least five minutes before re-igniting. This will allow the safety interlock to reset.

OPERATING PROCEDURES

Note: To operate the appliance with the Remote Control, it is necessary that the pilot flame is turned on and that the thermopile is hot enough to supply the power required by the gas valve. Furthermore the gas valve operating knob is required to be in the ON position.

Note: The Receiver has a temporary memory to store the commands sent by the Remote Control. When a command is received, an acoustic signal is generated to confirm the reception of the command and the command is stored. The command will be executed as soon as allowed by the control logic of the Receiver.

For instance an "ON" command sent immediately after the appliance has been turned off will be only executed after that the step motor modulator has returned to its maximum flame height position.

In the same way a command to set the flame level sent just after the appliance has been turned on will be executed only after the 5 second main burner ignition time at maximum flame height has elapsed.

With reference to the four keys arranged in a circle (see Fig. 13), the upper and lower keys (scrolling) allow the selection of the functions included in the Remote Control. The left and right keys (increase and decrease of the set points) allow modification of the working levels/states of the selected function.

The single push button is used to turn the appliance on and off.

The Remote Control will transmit when a key is pressed and the time of each transmission selection will not be longer than one second.

Turn on the appliance

If the appliance and the Remote Control are switched off, the icon "little house" with the measurement of the room temperature is shown on the LCD display; see Fig.12. When the ON/OFF key is pressed, the other icons will become visible on the LCD display. This indicates that the Remote Control is switched on. At the same time the Receiver connects the power of the thermopile to the gas valve millivolt coil and the appliance main burner turns on. An acoustic signal from the Receiver confirms the reception of the command.

Note: Upon turning the Transmitter to on be aware that the system holds the flame height to the maximum value for 5 seconds to allow a proper ignition of the burner. Attempts to increase or decrease the flame height during this period will be ignored.

Turn off the appliance

If the appliance and the Remote Control are switched on, when the ON/OFF key is pressed, the Remote control is turned off. At the same time the Receiver removes power from the gas valve millivolt coil and the appliance main burner turns off. An acoustic signal from the Receiver confirms the reception of the command.

Note: Upon turning the Transmitter to off, the system will drive the step motor modulator to the maximum flame height position, preparing the system for the next ignition. Therefore if during this time an "ON" command is sent, it will be executed once the step motor modulator has reached the maximum flame height position.

Flame height

This function allows remote control of the flame height.

Check that the Remote Control is on, otherwise, turn on the Remote Control and wait 5 seconds.

Select the manual flame height function using the UP or DOWN key until the cursor (small triangle) is to the left of the big flame (see Fig. 19).

Use the RIGHT or LEFT key to set the desired flame height. Six flame levels are included, from 1 (minimum) to 6 (maximum), see Fig. 20.

An acoustic signal from the Receiver confirms the reception of the command.

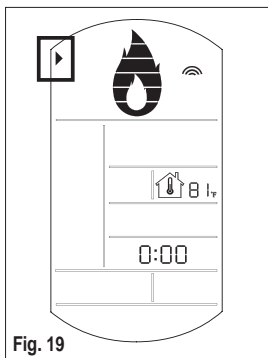

Fig. 19

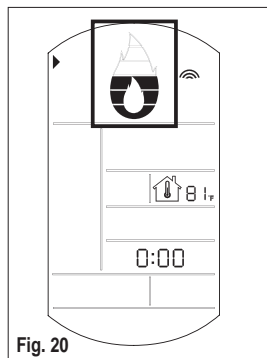

Fig. 20

Room thermostat

The Remote Control can operate as a room thermostat.

To activate this function use the UP or DOWN key until the cursor (small triangle) is left of the thermometer icon, see Fig. 21.

Then use the RIGHT or LEFT key to set the desired room temperature, see Fig. 22.

The control system will cycle automatically the appliance on or off to maintain the selected temperature.

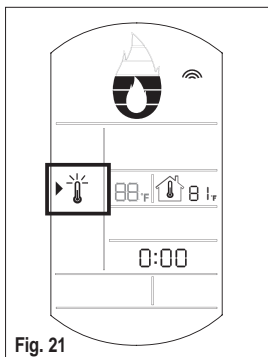

Fig. 21

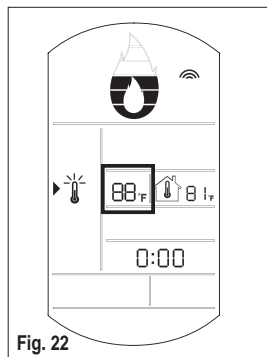

Fig. 22

Timer setting

The Remote Control has a sleep function. With this function it is possible to set a sleep time. After this time has elapsed the appliance is automatically switched off.

To activate the function use the UP or DOWN key until the cursor (small triangle) is to the left of the clock icon, see Fig. 23.

Then use the RIGHT or LEFT key to set the desired sleep time, see Fig. 24

It is possible to set a maximum time of 90 minutes with 15 minutes steps.

After the desired time has been set press the UP or DOWN key to start the timer.

Child safety lock-out

This function is to deactivate the remote control keys. The function is active when the lock icon is lit, see Fig. 25.

To activate this function press the ON/OFF key and within one second the UP key.

To reactivate the remote control keys follow the same sequence, press ON/OFF key and within one second press the UP key.

Low battery detection and Backup

The duration of the batteries depends on many factors: the quality of the batteries used, the number of ignitions of the appliance, the number of the flame height, etc.

When the Receiver detects a low battery condition, it operates in the following way:

- Three acoustic signals are generated
- The appliance is turned off and the modulator motor is driven to the maximum flame height position
- The execution of any command received is ignored while the low battery condition remains.

As soon as the depleted batteries are replaced, the Receiver will restart its normal operation.

During a low battery condition it is not possible to turn on the appliance with the Remote Control. It is possible to turn the appliance on manually using the Backup switch of the Receiver set to the MAN position.

When set to MAN, the power of the thermopile is connected to the gas valve coil allowing ignition of the main burner of the appliance.

Note: As soon as the exhausted batteries are replaced and with the BACKUP switch in AUTO position, the Receiver leaves the appliance turned off even if the Remote Control is turned on. In this case, to switch on the appliance, press the ON/OFF button of the Remote Control twice.

When the transmitter batteries are low, an icon will be displayed on the LCD display (see Fig. 26) to alert of a low battery condition before losing battery power at all. As soon as the depleted

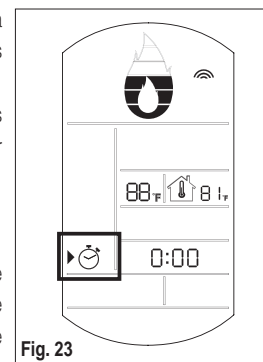

Fig. 23

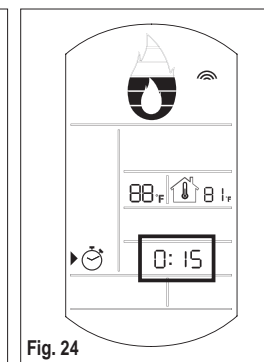

Fig. 24

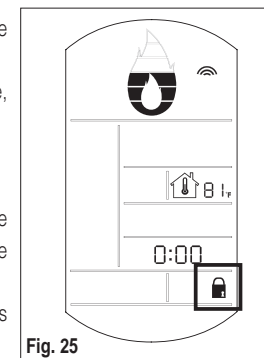

Fig. 25

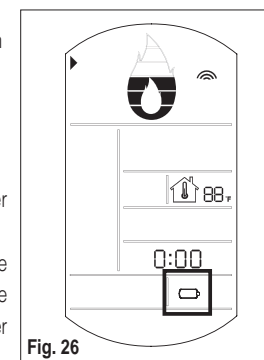

Fig. 26

batteries are replaced, the Transmitter will restart its normal operation.

Timeout

If the appliance is turned on and the Receiver does not receive any command for 24 hours, it automatically turns the appliance and the Remote Control off.

DIMENSIONAL DRAWINGS

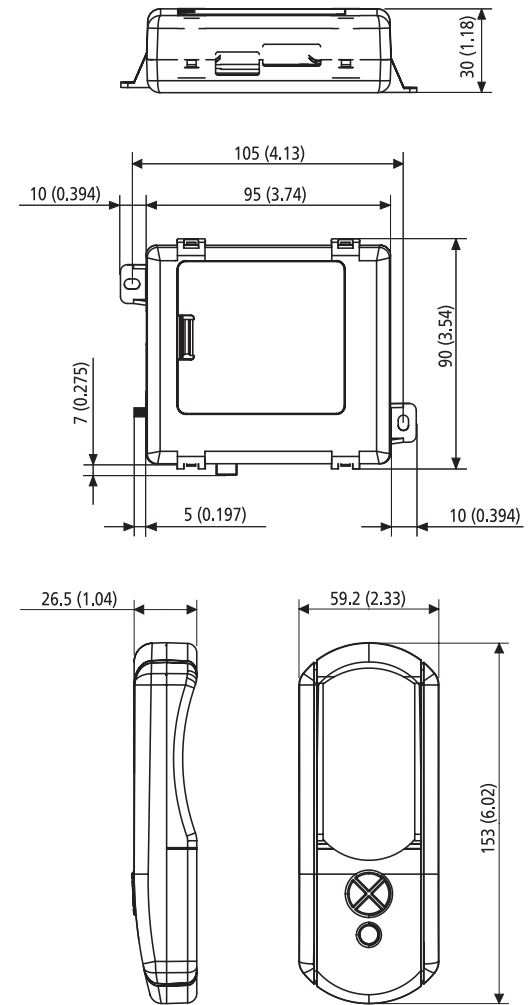

NOTE: All the dimensions are expressed in millimeters (inches).



Fig. 1

The SIT 584 PROFLAME System is a device that allows, in conjunction with the Combination Gas Control, to command appliances like fireplaces and logs.

Using a simple Transmitter it is possible to turn the appliance on and off, furthermore the flame height can be manually incremented up and down to one of six settings. Backup function is also included.

The 584 PROFLAME System consists of the 584 PROFLAME Transmitter, the 584 PROFLAME Battery Receiver and the necessary harness to connect the Receiver to the Gas Valve; see Fig. 1.

The 584 PROFLAME System is designed to only command the 820 NOVA mV converted with the STEP MOTOR modulating kit or the 825 NOVA PROFLAME Combination Gas Control; see Fig. 2.

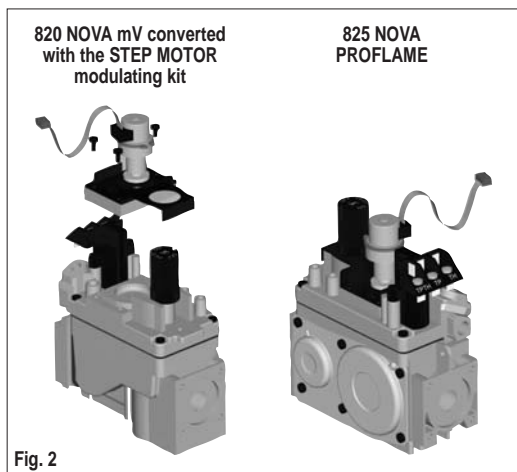

Fig. 2

TECHNICAL DATA

Remote Control

Supply voltage	12 V (one V23A battery)
Ambient temperature ratings	0 - 60 °C (32 - 140 °F)
Number addresses	128
Radio frequency	433.92 MHz

Receiver

Supply voltage	6 V (four 1.5 V AA batteries)
Ambient temperature ratings	0 - 60 °C (32 - 140 °F)
Number addresses	128
Radio frequency	433.92 MHz

WARNING

Fire Hazard. Can cause severe injury or death

The Receiver causes the ignition of the fireplace. The fireplace can turn on suddenly. Keep away from the burner, especially when operating on the BACKUP switch.

CAUTION

Property Damage Hazard.

Excessive heat can cause property damage

The fireplace can stay ignited for many hours. Take care to turn off the fireplace if it is unattended by adult people.

Do not leave the Remote Control where children can reach it.

FCC NOTICE

This equipment has been tested and found to comply with the limits for a Class B digital device, pursuant to Part 15 of FCC Rules. These limits are designed to provide reasonable protection against harmful interference in a residential installation.

This equipment generates, uses and can radiate radio frequency energy and, if not installed and used in accordance with the instructions, may cause harmful interference to radio communications. However, this is no guarantee that interference will not occur in a particular installation.

If this equipment does cause harmful interference to radio or television reception, which can be determined by turning the equipment off and on, the user is encouraged to try to correct the interference by one or more the following measures:

- Reorient or relocate the receiving antenna.
- Increase the separation between the equipment and Receiver.
- Connect the equipment into an outlet on a circuit different from that to which the Receiver is connected.
- Consult the dealer or an experienced radio/TV technician for help.

INSTALLATION

Installation of the Receiver

The Receiver must be screwed up to the appliance using the holes that are present on two sides of the Receiver, see Fig. 3. The mounting hardware is not supplied.

Automatic / Manual Selection

Set the BACKUP switch to AUTO position; see Fig. 4.

Step Motor connection

Connect the step motor cable of the gas valve to the proper connector of the Receiver; see Fig. 5.

Thermopile connection

Connect the "+" (positive) terminal of the thermopile to the TP terminal of the gas valve. Connect the "-" (negative) terminal of the thermopile to the TPTH terminal of the gas valve; see Fig. 6.

Connection of the Receiver to the gas valve

Connect the SIT 7.228.198 cable (supplied with the package) to the receiver GAS VALVE connector; see Fig. 7. Then the red wire must be connected to the TH terminal of the gas valve while the black wire must be connected to the TPTH terminal of the gas valve; see Fig. 6.

Receiver setting address

The Remote Control and the Receiver shall have the same address. Select, with the proper dip-switches, addresses of the Receiver and that of the Remote Control; see Fig. 8 and Fig. 9. See table in the Appendix for the proper settings. Switch #8 must always be in the ON position (down).

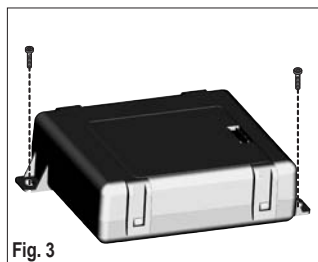

Fig. 3



Fig. 4: BACKUP switch



Fig. 5: Step Motor connector

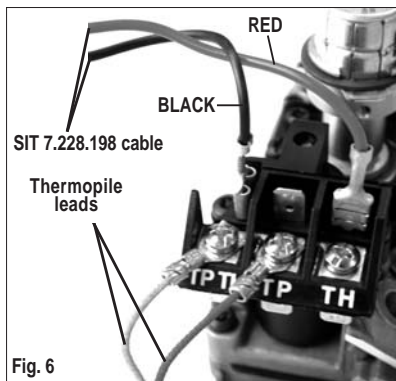

Fig. 6



Fig. 7

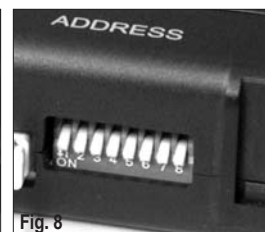

Fig. 8



Fig. 9

Receiver batteries installation

Insert in the proper compartment four 1.5 V AA batteries. Do not reverse the polarity of the batteries; see Fig. 10. At this time the Receiver is powered and after a few seconds, needed to perform the step motor calibration, a short sound will be generated to indicate that the device is ready to receive commands from the Remote Control.



Fig. 10

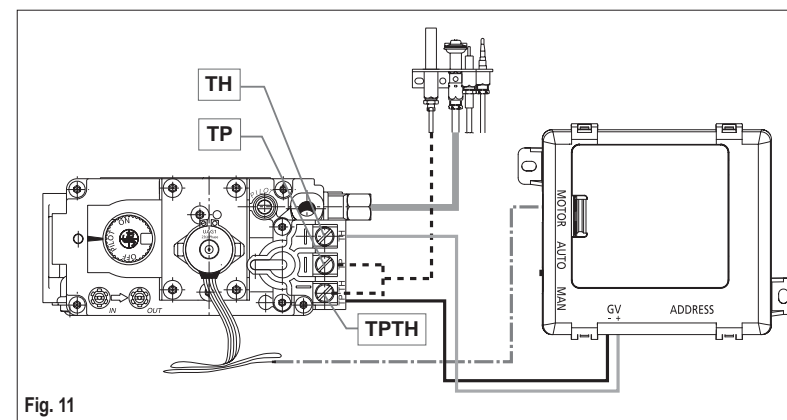

Fig. 11

SYSTEM CONTROL OPERATION

Preliminary check of the Receiver

Operations to be done, before switching on the Remote Control:

- Check that the electrical connections are in accordance with Fig. 11.
- Install the batteries (4 x 1.5 V AA) in the proper compartment and wait for the generation of the acoustic signal ("beep") as a confirmation that the Receiver is working; see Fig. 10.
- Check that the BACKUP switch is in AUTO position (to the left) to let the Remote Control operate the gas valve; see Fig. 4.

Note: All the above operations can be done without turning on the pilot flame in the appliance.

Check the functionality of the Remote Control

The Remote Control is powered by one miniature 12 V (V23A) battery in the proper compartment with the correct polarity; see Fig. 9. The correct power of the Remote Control can be checked observing the presence of the red light when one button is pressed; see Fig. 12.

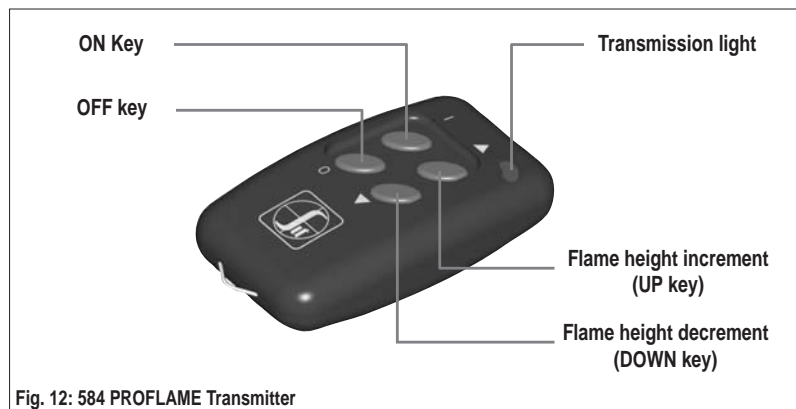

Fig. 12: 584 PROFLAME Transmitter

Check the communication between the Remote Control and the Receiver

When the I key is pressed the red light is activated to indicate the transmission of a command to the Receiver; see Fig. 12. At the same time the Receiver will generate an acoustic signal to indicate the reception of the command.

If the acoustic signal isn't generated, take place at a lower distance from the Receiver and press the I key.

If again the acoustic signal is not generated it is necessary to execute the address setting procedure described below.

Address setting procedure

The transmitter address is required to be equal to the Receiver. Select, through setting of the dip switches, the address of the Remote Control (see Fig. 8) and that of the Receiver (see Fig. 9).

See the table in the Appendix for the proper settings of the switches. Switch #8 must always be in the ON position (down).

Note: The address of the Receiver is acquired only at its power on. Changing the address while the Receiver is powered will not have any effect. To change the address of the Receiver, disconnect the batteries from the Receiver, change the address and reconnect the batteries again.

VALVE OPERATION

WARNING

Fire or Explosion Hazard. Can cause damage to property and severe injury or death.

Do not force the control knob. Use only your hand to turn the knob. If the knob does not move by hand, the valve should be replaced by a trained service technician.

Set the Remote Control OFF. Press slightly and turn the control knob clockwise to the "OFF" position and wait five minutes; thus allowing any gases to escape which may have accumulated in the combustion chamber.

Note: LP gases do not vent upward.



Pilot flame ignition

Press slightly and rotate the control knob to the "PILOT" position. Press the knob and light the pilot flame, keeping the knob fully depressed for at least thirty (30) seconds until air in the pilot line vents and a strong pilot flame is present. Release the knob and verify that the pilot flame remains lit.

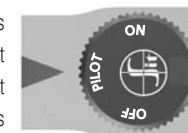

Igniting the main burner

Turn the control knob to the "ON" position. With the knob in this position the gas valve is ready to be operated by the Receiver.

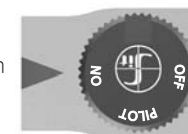

Pilot position

To maintain flame to the pilot burner with the main burner off, turn the control knob to the "PILOT" position.

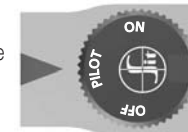

Turning off

Turn the control knob to the "OFF" position to switch OFF both main and pilot burner.

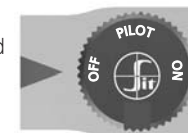

CAUTION

After shutting off, wait at least five minutes before re-igniting. This will allow the safety interlock to reset.

OPERATING PROCEDURES

Note: To operate the appliance with the Remote Control, it is necessary that the pilot flame is turned on and that the thermopile is hot enough to supply the power required by the gas valve. Furthermore the gas valve operating knob is required to be in the ON position.

Note: The Receiver has a temporary memory to store the commands sent by the Remote Control. When a command is received, an acoustic signal is generated to confirm the reception of the command and the command is stored. The command will be executed as soon as allowed by the control logic of the Receiver.

For instance an "ON" command sent immediately after the appliance has been turned off will be only executed after that the step motor modulator has returned to its maximum flame height position.

In the same way a command to set the flame level sent just after the appliance has been turned on will be executed only after the 5 second main burner ignition time at maximum flame height has elapsed.

The Remote Control will transmit when a key is pressed and the transmission time will not be longer than 1 second even if the key is maintained pressed.

Turn on the appliance

When the **I** key is pressed on the Remote Control, the Receiver connects the power of the thermopile to the gas valve millivolt coil and the appliance main burner turns on.

An acoustic signal from the Receiver confirms the reception of the command.

Note: Upon turning the Transmitter to on be aware that the system holds the flame height to the maximum value for 5 seconds to allow a proper ignition of the burner. Attempts to increase or decrease the flame height during this period will be ignored.

Turn off the appliance

When the **O** key is pressed on the Remote Control the Receiver removes power from the gas valve millivolt coil and the appliance main burner turns off. An acoustic signal from the Receiver confirms the reception of the command.

Note: Upon turning the Transmitter to off, the system will drive the step motor modulator to the maximum flame height position, preparing the system for the next ignition. Therefore if during this time an "ON" command is sent, it will be executed once the step motor modulator has reached the maximum flame height position.

Flame height

This function allows remote control of the flame height.

Check that the appliance is turned on, otherwise press the **I** key on the Remote Control and wait 5 seconds. Use the **▼** or **▲** key to set the desired flame height; see Fig. 12. Six flame levels are included. An acoustic signal from the Receiver confirms the reception of the command.

Low battery detection and backup

The duration of the batteries depends on many factors: the quality of the batteries used, the number of ignitions of the appliance, the number of changes to the flame height, etc.

When the Receiver detects a low battery condition, it operates in the following way:

- Three acoustic signals are generated
- The appliance is turned off and the modulator motor is driven to the maximum flame height position
- The execution of any command received is ignored while the low battery condition remains.

As soon as the depleted batteries are replaced, the Receiver will restart its normal operation.

During a low battery condition it is not possible to turn on the appliance with the Remote Control. It is possible to turn the appliance on manually using the Backup switch of the Receiver set to the MAN position.

When set to MAN, the power of the thermopile is connected to the gas valve coil allowing ignition of the main burner of the appliance.

Timeout

If the appliance is turned on and the Receiver does not receive any command for 24 hours, it turns the appliance off.

DIMENSIONAL DRAWINGS

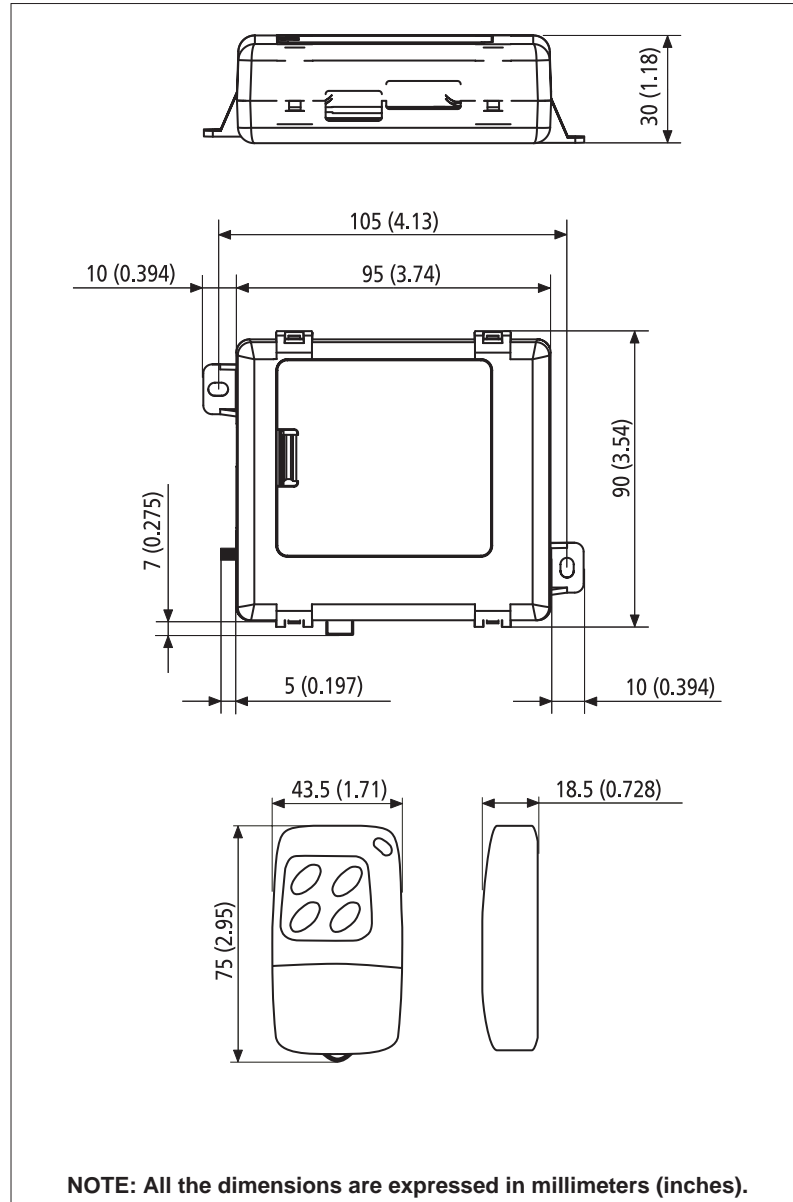

ADDRESS	1	2	3	4	5	6	7	8
0	0	0	0	0	0	0	0	0
1	1	0	0	0	0	0	0	0
2	0	1	0	0	0	0	0	0
3	1	1	0	0	0	0	0	0
4	0	0	1	0	0	0	0	0
5	1	0	1	0	0	0	0	0
6	0	1	1	0	0	0	0	0
7	1	1	1	0	0	0	0	0
8	0	0	0	1	0	0	0	0
9	1	0	0	1	0	0	0	0
10	0	1	0	1	0	0	0	0
11	1	1	0	1	0	0	0	0
12	0	0	1	1	0	0	0	0
13	1	0	1	1	0	0	0	0
14	0	1	1	1	0	0	0	0
15	1	1	1	1	0	0	0	0
16	0	0	0	0	1	0	0	0
17	1	0	0	0	1	0	0	0
18	0	1	0	0	1	0	0	0
19	1	1	0	0	1	0	0	0
20	0	0	1	0	1	0	0	0
21	1	0	1	0	1	0	0	0
22	0	1	1	0	1	0	0	0
23	1	1	1	0	1	0	0	0
24	0	0	0	1	1	0	0	0
25	1	0	0	1	1	0	0	0
26	0	1	0	1	1	0	0	0
27	1	1	0	1	1	0	0	0
28	0	0	1	1	1	0	0	0
29	1	0	1	1	1	0	0	0
30	0	1	1	1	1	0	0	0
31	1	1	1	1	1	0	0	0
32	0	0	0	0	0	1	0	0
33	1	0	0	0	0	1	0	0
34	0	1	0	0	0	1	0	0
35	1	1	0	0	0	1	0	0
36	0	0	1	0	0	1	0	0
37	1	0	1	0	0	1	0	0
38	0	1	1	0	0	1	0	0
39	1	1	1	0	0	1	0	0
40	0	0	0	1	0	1	0	0
41	1	0	0	1	0	1	0	0
42	0	1	0	1	0	1	0	0
43	1	1	0	1	0	1	0	0
44	0	0	1	1	0	1	0	0
45	1	0	1	1	0	1	0	0
46	0	1	1	1	0	1	0	0
47	1	1	1	1	0	1	0	0
48	0	0	0	0	1	1	0	0
49	1	0	0	0	1	1	0	0
50	0	1	0	0	1	1	0	0
51	1	1	0	0	1	1	0	0
52	0	0	1	0	1	1	0	0
53	1	0	1	0	1	1	0	0
54	0	1	1	0	1	1	0	0
55	1	1	1	0	1	1	0	0
56	0	0	0	1	1	1	0	0
57	1	0	0	1	1	1	0	0
58	0	1	0	1	1	1	0	0
59	1	1	0	1	1	1	0	0
60	0	0	1	1	1	1	0	0
61	1	0	1	1	1	1	0	0
62	0	1	1	1	1	1	0	0
63	1	1	1	1	1	1	0	0

ADDRESS	1	2	3	4	5	6	7	8
64	0	0	0	0	0	0	1	0
65	1	0	0	0	0	0	1	0
66	0	1	0	0	0	0	1	0
67	1	1	0	0	0	0	1	0
68	0	0	1	0	0	0	1	0
69	1	0	1	0	0	0	1	0
70	0	1	1	0	0	0	1	0
71	1	1	1	0	0	0	1	0
72	0	0	0	1	0	0	1	0
73	1	0	0	1	0	0	1	0
74	0	1	0	1	0	0	1	0
75	1	1	0	1	0	0	1	0
76	0	0	1	1	0	0	1	0
77	1	0	1	1	0	0	1	0
78	0	1	1	1	0	0	1	0
79	1	1	1	1	0	0	1	0
80	0	0	0	0	1	0	1	0
81	1	0	0	0	1	0	1	0
82	0	1	0	0	1	0	1	0
83	1	1	0	0	1	0	1	0
84	0	0	1	0	1	0	1	0
85	1	0	1	0	1	0	1	0
86	0	1	1	0	1	0	1	0
87	1	1	1	0	1	0	1	0
88	0	0	0	1	1	0	1	0
89	1	0	0	1	1	0	1	0
90	0	1	0	1	1	0	1	0
91	1	1	0	1	1	0	1	0
92	0	0	1	1	1	0	1	0
93	1	0	1	1	1	0	1	0
94	0	1	1	1	1	0	1	0
95	1	1	1	1	1	0	1	0
96	0	0	0	0	0	1	1	0
97	1	0	0	0	0	1	1	0
98	0	1	0	0	0	1	1	0
99	1	1	0	0	0	1	1	0
100	0	0	1	0	0	1	1	0
101	1	0	1	0	0	1	1	0
102	0	1	1	0	0	1	1	0
103	1	1	1	0	0	1	1	0
104	0	0	0	1	0	1	1	0
105	1	0	0	1	0	1	1	0
106	0	1	0	1	0	1	1	0
107	1	1	0	1	0	1	1	0
108	0	0	1	1	0	1	1	0
109	1	0	1	1	0	1	1	0
110	0	1	1	1	0	1	1	0
111	1	1	1	1	0	1	1	0
112	0	0	0	0	1	1	1	0
113	1	0	0	0	1	1	1	0
114	0	1	0	0	1	1	1	0
115	1	1	0	0	1	1	1	0
116	0	0	1	0	1	1	1	0
117	1	0	1	0	1	1	1	0
118	0	1	1	0	1	1	1	0
119	1	1	1	0	1	1	1	0
120	0	0	0	1	1	1	1	0
121	1	0	0	1	1	1	1	0
122	0	1	0	1	1	1	1	0
123	1	1	0	1	1	1	1	0
124	0	0	1	1	1	1	1	0
125	1	0	1	1	1	1	1	0
126	0	1	1	1	1	1	1	0
127	1	1	1	1	1	1	1	0

