

1-269-685-4123

www.allpartsinc.com

Instructions for Reseating Thermocouple & Cleaning Pilot/ODS

Symptom: Pilot/ODS lights when the pilot/control knob is pressed but flame goes out as soon as the pilot/control knob is released.

WARNING

Only a state licenced or qualified service technician should service and repair appliance. Turn off gas and electric to appliance and let cool before servicing. Never service an appliance while the unit is still in operation or still hot. Never service any appliance, fireplace or heater that is plugged in to any electrical source. Always test appliance, fireplace or heater for gas leaks after repair. Follow instructions to help prevent risk of electrical shock or severe burns.

This is one of the most commonly asked questions our service technicians receive in our customer service department.

The goal with this publication is to try and answer this question from both the technical service side of the problem as well as the everyday application and understanding answer side.

The easy answer is just to replace the Thermocouple or the Pilot/ODS Assembly and this will typically solve the problem...but why did that solve the problem?

Many times this resolves the problem because the thermocouple has developed a bad seating connection between the thermocouple fixing nut and the Thermo-Electric valve located inside of your actual control valve assembly and when the new thermocouple fixing nut is tightened into Thermo-Electric valve it will cause what is called a "New Seat". Meaning the connection between the end of the thermocouple wire just above the thermocouple fixing nut and the seat which is inside the Thermo-Electric valve have now made a new connection that now allows current to pass through the connection and into the Thermo-Electric valve. Which then allows the control valve to stay open and allow gas to pass through the control valve into both the pilot and the main burner once again.

When this connection happens properly the thermocouple and the control valve basically "talk" to each other, the thermocouple says to the control valve "Hey I have a good flame here so lock the Thermo-Electric valve open and let's turn on the gas to the burner and make some heat"

Now in technical terms the thermocouple sends a small milliamp (mA) current to the Thermo-Electric Unit inside the control valve. This mA current needs to be between a certain Hold-In and Drop-Out current level that is different depending on what type of appliance; heater or fireplace the thermocouple and control valve are being used on.

This milliamp current is produced when two dissimilar metallic materials are heated together along with a conducting material, thus producing a milliamp (mA) current.

For more technical information on this process see the Seebeck effect developed by Thomas Johann Seebeck 1821.

With all of that being stated what should I do first to determine if my thermocouple is defective or if my Pilot/ODS is just dirty or if my thermocouple has a poor connection.

Symptom: Pilot/ODS lights when the pilot/control knob is pressed but flame goes out as soon as the pilot/control knob is released.

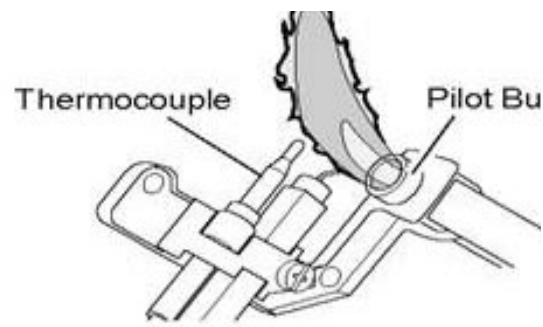
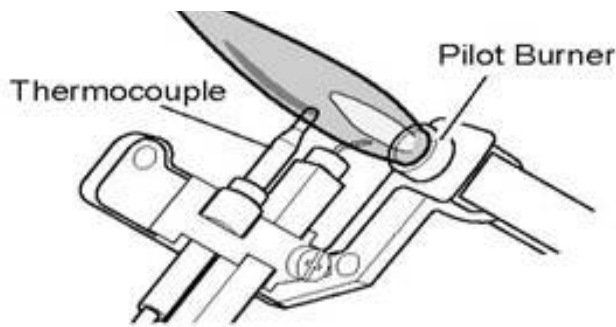

Figure 18: Correct Pilot Flame Pattern Figure 19: Incorrect Pilot Flame Pattern

First we must determine if our Pilot Flame is correct and heating our thermocouple properly.

PILOT FLAME PATTERN:

Figure 18 shows a correct pilot flame pattern. Figure 19 shows an incorrect pilot flame pattern.

The incorrect pilot flame is not touching the thermocouple properly and this will cause the thermocouple to cool and reach the Drop-Out temperature. When the thermocouple cools down to the Drop-Out temperature the Thermal Electric valve will release and the heater will shut down.

"Basically the thermocouple and the Control valve have quit talking to each other"

WARNING:

Turn off heater and let cool before cleaning.

CAUTION:

You must keep control areas, burner and circulating air passageways of heater clean. Inspect these areas of heater before each use. Have heater inspected yearly by a qualified service person. Heater may need more frequent cleaning due to excessive lint from carpeting, bedding material, pet hair, etc.

Let's start the cleaning and reconnection process before purchasing any new and costly replacement parts that may not be required to repair my appliance.

1. First we must make sure our appliance is clean.

ODS/PILOT AND BURNER:

- Use a vacuum cleaner, pressurized air, or small, soft bristled brush to clean.

It is recommended that you clean your appliance every season before use and depending upon climate and conditions this could be as frequently as every 2,500 hours of operation or every three months.

It is also recommended that you keep the burner assembly and Pilot/ODS assembly clean and free of dust and dirt as well as the rest of the appliance.

To clean these parts it is recommended that you use compressed air no greater than 30 PSI. Your local hardware store or home center may carry compressed air in a small can or you can use a vacuum cleaner in the blow position with a small nozzle.

If using compressed air in a can, please follow the directions on the can. If you don't follow directions on the can, you could damage the pilot assembly.

Shut off the appliance including the pilot and the main gas valve as well as unplug the appliance from any source of power.

Allow the appliance, heater, fireplace to cool for at least thirty minutes before proceeding to clean and inspect the unit.

CAUTION:

Use of a shield or safety glasses to protect your eyes and face from dust and debris is recommended during the cleaning process.

CAUTION:

Use of a dust mask is recommended during the cleaning process to help prevent and ingestion of dust and debris which can carry bacteria.

Start by blowing dust, dirt and any other accumulated particles or debris from the cabinet and body of the appliance, heater or fireplace box.

Inspect the Burner and Pilot/ODS for dust and dirt.

Blow air lightly through the gas ports holes and air slots in the burner.

Clean the Pilot/ODS assembly:

A yellow tip on the pilot flame normally indicates dust and dirt in the pilot assembly. There is a small pilot air inlet hole about two inches from where the pilot flame comes out of the pilot assembly (see Figure 22). With the gas off, lightly blow air through the air inlet hole to insure there is no obstructions in the Pilot Air Inlet Hole.

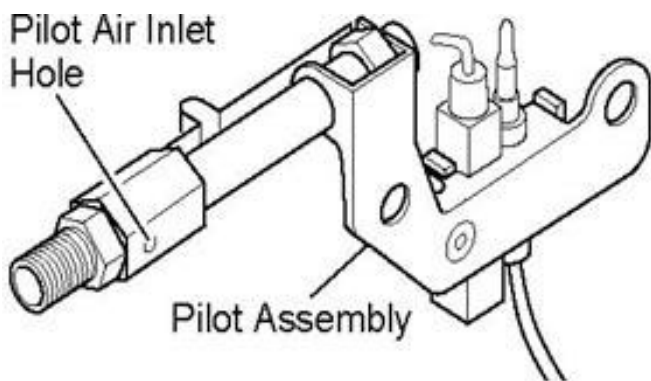

Figure 22: Pilot Inlet Air Hole

2. Secondly we must make sure we are achieving a proper contact between our thermocouple and our Thermo-Electric unit.

Remember the Thermo-Electric unit in the part that allows the thermocouple and the control valve to talk to each other and let gas come through the system and into the pilot and burner.

"When this connection happens properly the thermocouple and the control valve basically "talk" to each other, the thermocouple says to the control valve 'Hey I have a good flame here so lock the Thermo-Electric valve open and let's turn on the gas to the burner and make some heat'"

Remove the thermocouple wire from the gas control valve Thermo-Electric unit by turning fitting counter clockwise with a 5/16 wrench. (See Figure 1)

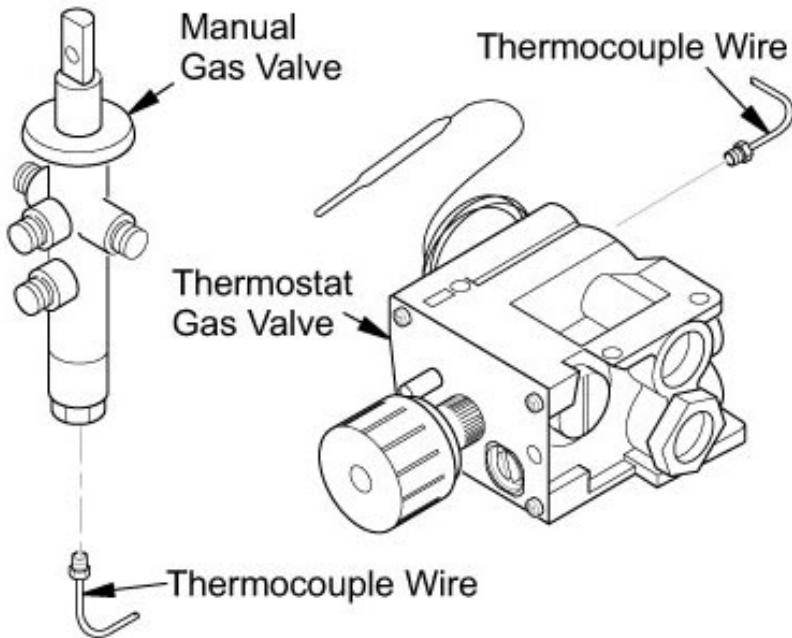

Figure 1: Thermocouple Connection to gas Valves

Once the thermocouple fitting has been loosened and the thermocouple has been removed inspect the thermocouple Power Unit Connector Contact (PUCC). (See Figure 1A)

Although the PUCC may appear clean many times the PUCC has developed a thin layer of corrosion that prevents the thermocouple from sending the needed current to the Thermo-Electric unit resulting in a pilot flame that may only remain burning strong as long as the pilot button is being pushed by the operator.

After removing the thermocouple PUCC from the valve you will need to clean both the power unit connector contact and the Thermo-Electric valve seat contact.

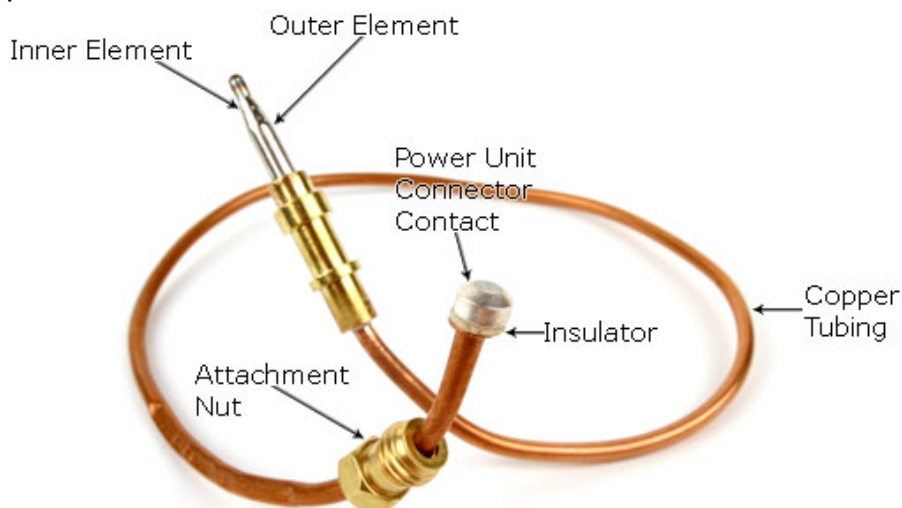

Figure 7: Thermocouple

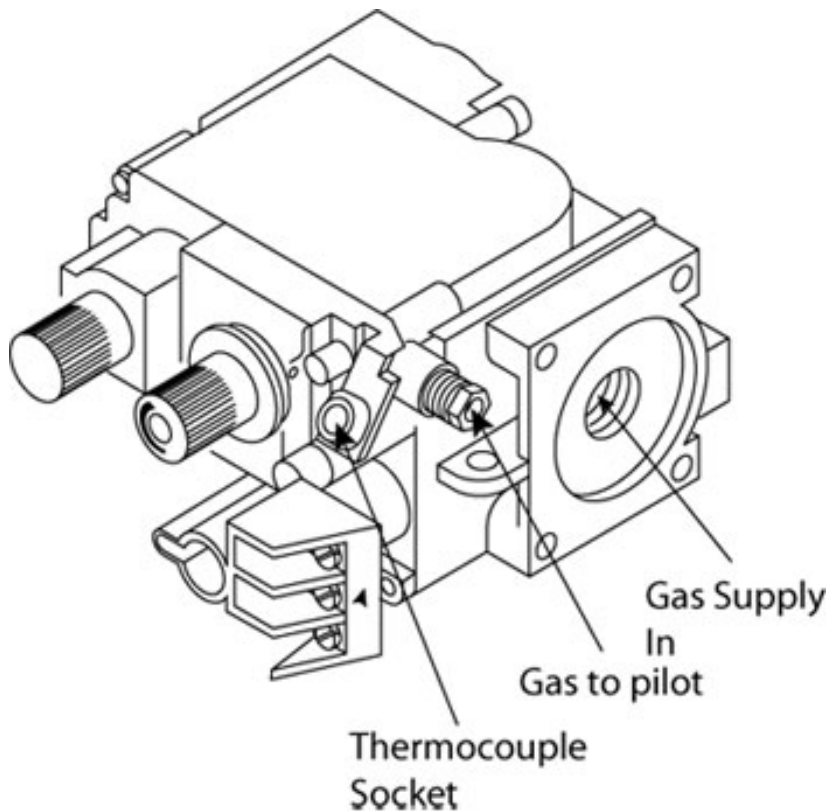

Figure 8

The connecting will require that a small amount of new clean metal be exposed providing a new fresh metal seat for the PUCC and the Thermo-Electric valve.

With some emery cloth or a metal pick expose some new metal on both the PUCC and then up inside the Thermal-Electric valve seat scraping just a small amount of old surface from each item.

This new fresh metal seat will allow the millivolt current generated from the thermocouple to energize the Thermo-Electric valve and allow the gas control valve to remain in the open position.