

IRSFA200

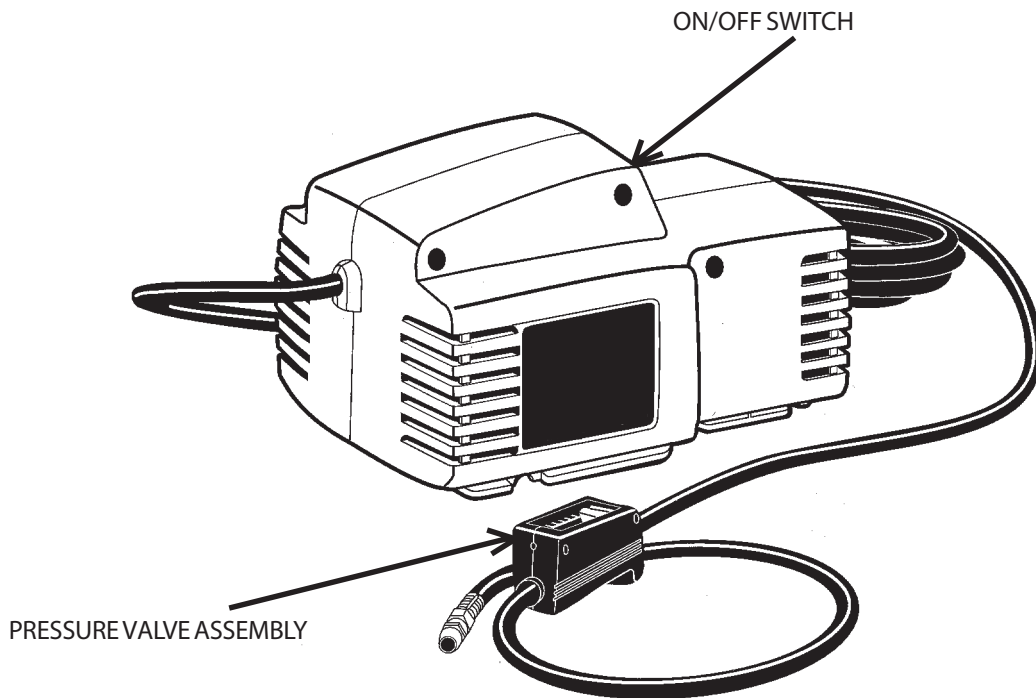

<u>DESCRIPTION</u>	<u>PART NUMBER</u>
Pressure Valve Assembly (hose included)	CAC-4324
Air Chuck	SSH-8
Adapter	H-2099

FAC200 (cont'd)

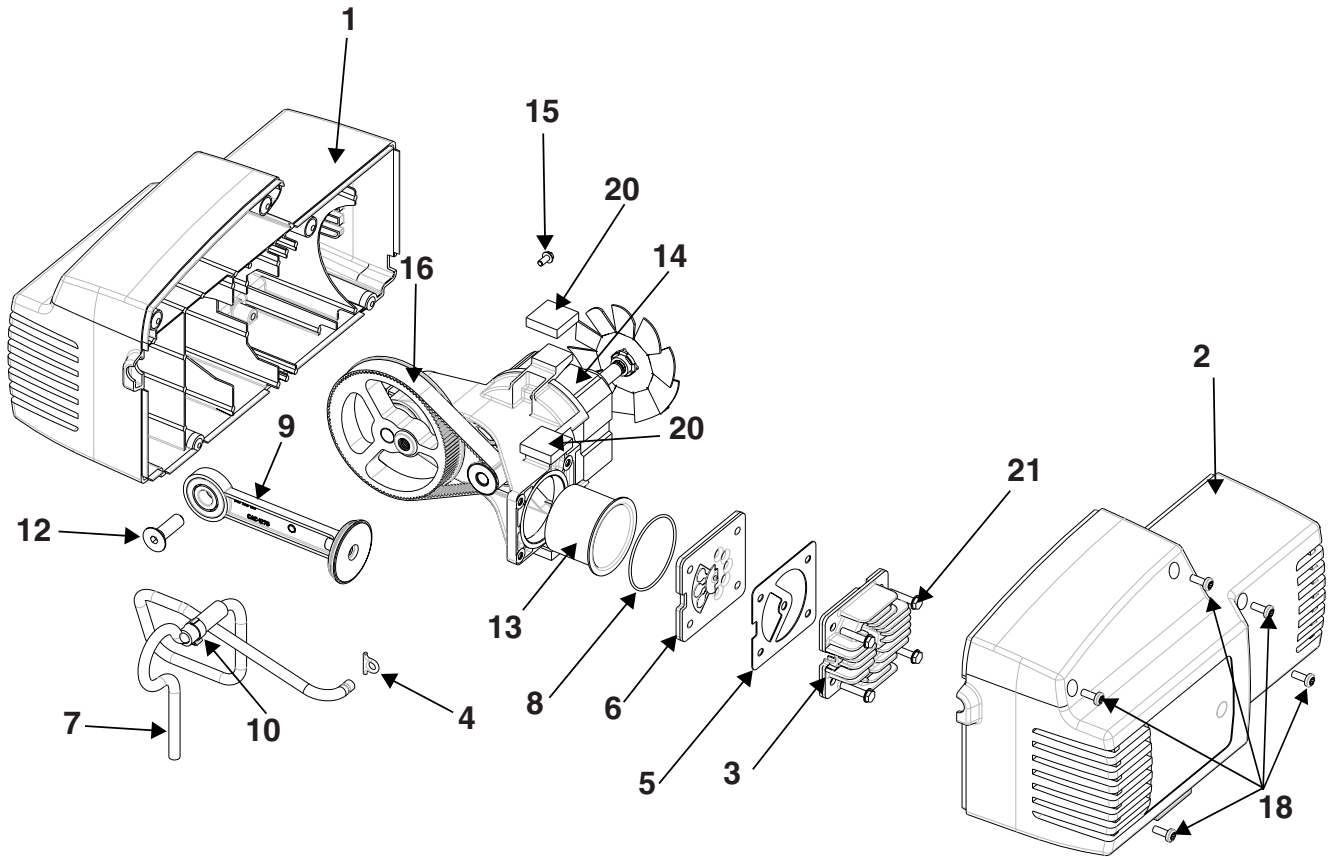

FAC200 (cont'd)

	<u>Part Number</u>	<u>Description</u>
1	AC-0471	Shroud, Left
2	AC-0470	Shroud, Right
3	CAC-1196	Cylinder Head
4	* CAC-1212	Tube Seal
5	* CAC-1199	Gasket Head
6	CAC-4323	Valve Plate Assembly
7	CAC-1194-1	Outlet Tube
8	* SSG-8169	O-ring
9	+ -----	Rod Assembly
10	CAC-1206-1	Clamp
11	-----	-----
12	x SSF-3147	Screw, 3/8-16 socket head
13	+ -----	Cylinder Sleeve
14	N/A	Endbell Assembly
15	x SUDL-9-1	Screw, 8-32x .375/.344
16	CAC-1342	Timing Belt
18	SSF-3156	Screw, 10-9x.50Plastite
19	AC-0475	Motor Cord
20	* CAC-1213	Pump Isolator (5 used)
21	x SSF-995	Screw #10-24 x 7/8 LG. Hex head thd forming (4 used)

NOT ILLUSTRATED

MGP-FAC200 Owners Manual

- * KK-4930– Isolator Kit
- + KK-4964 – Connecting Rod Kit
- x KK-4929 – Fastener Kit