

IRFB5520VP-WK-1

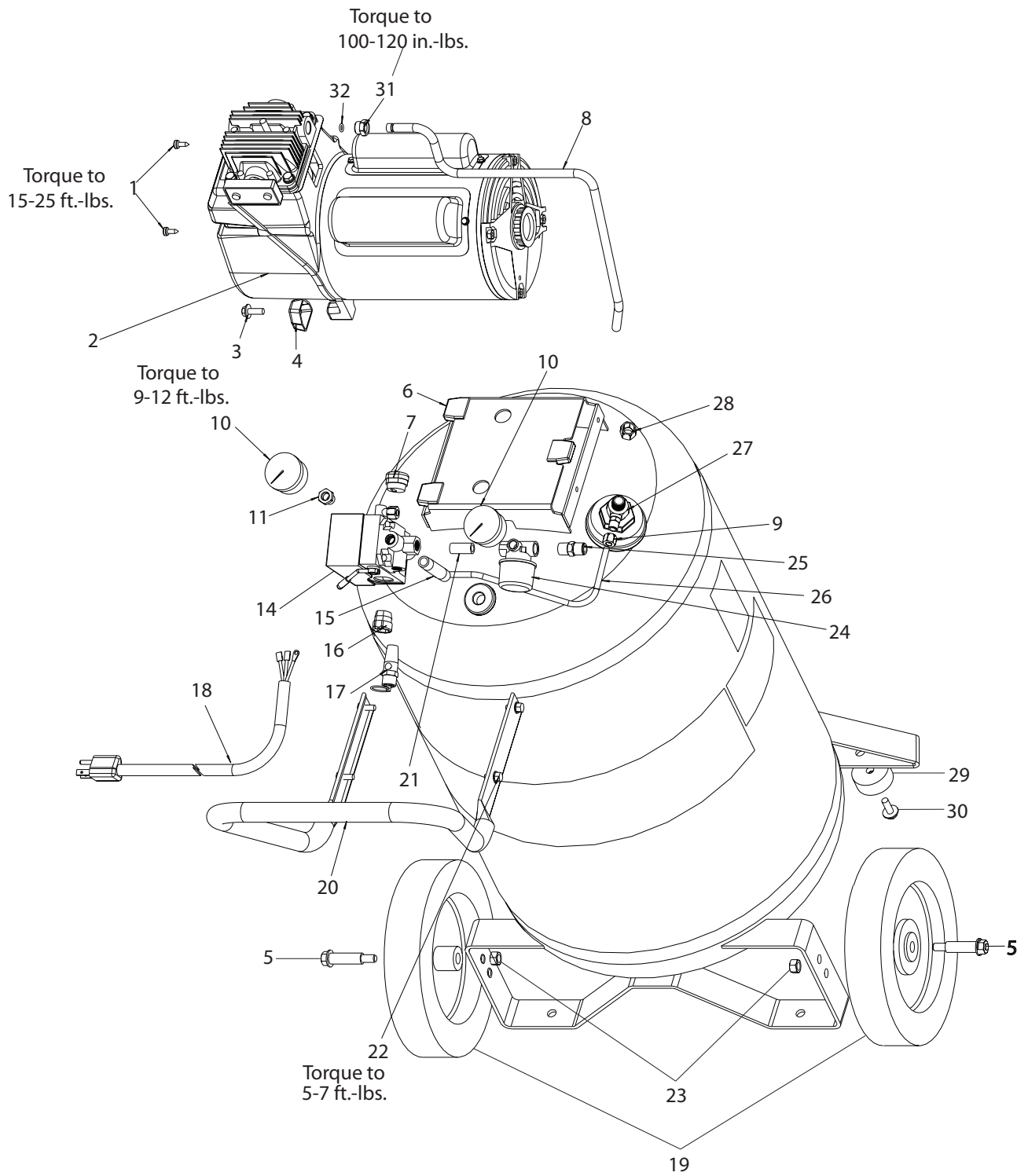

FB5525VP-1 (cont'd)

KEY NO.	PART NUMBER	DESCRIPTION
1	ACG-408	Fastener Assembly (2 used)
2	AC-0376	Mini Shroud
3	91895680	Screw, 1/4-20 x .75 (2 used)
4	ACG-18	Cup, Saddle Mount (2 used)
5	CAC-60	Shoulder Bolt (2 used)
6	AC-0774	Isolator (3 used)
7	SSW-7367	Bushing, Strain Relief
8	AC-0605-1	Outlet Tube
9	SSP-7811	Nut/Sleeve Assembly (1/4")
10	GA-352	Gauge (2 used)
11	SSP-6021	Reducer Bushing (1/8"-1/4NPT)
14	D21299	Pressure Switch
15	SSP-480	Nipple, 1/4 x 2.5"
16	SSW-7385	Bushing, Strain Relief
17	TIA-4150	Safety Valve
18	SUDL-413-2	Cord Assembly
19	AC-0014	Wheel - 9" (2 used)
20	AC-0609	Handle
21	SS-1286	Nipple 1/4" - 18 NPT
22	SSF-981	Screw (4 used)
23	SSF-8080-ZN	Nut, Hex 3/8-16 UNC - 2B (2 used)
24	CAC-4296-1	Regulator
25	H-2099	Adaptor (1/4" NPT x 1/4" NPSM)
26	AC-0630	Pressure Relief Tube
27	AC-0631	Check Valve
28	SSP-7813	Nut/Sleeve Assembly (3/8")
29	SST-107	Rubber Bumper (2 used)
30	SSF-630	Bumper Screw (2 used)
31	SSP-7821-1	Tube Nut
32	SSG-3105	O-Ring
	<u>NOT SHOWN</u>	
	SS-2707	Drain Valve

FB5525VP-1 (cont'd)

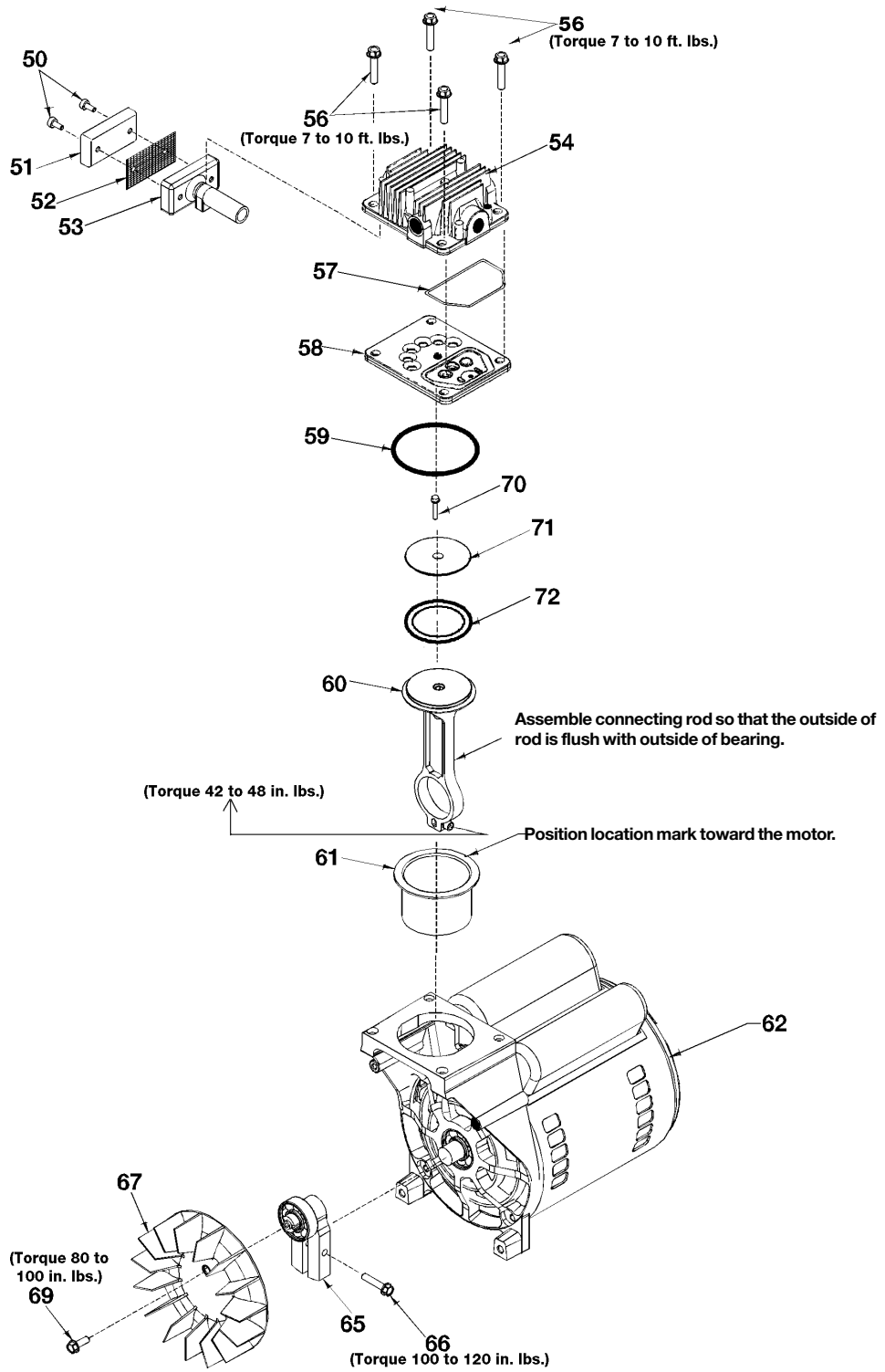

FB5525VP-1 (cont'd)

KEY		
NO.	PART NUMBER	DESCRIPTION
+ 50	---	Air filter fastener (2 used)
51	DAC-143	Air filter
+ 52	---	Muffler screen
+ 53	---	Intake muffler
54	AC-0037	Head
56	SSF-927	Screw 1/4-20 x 1 1/4" (4 used)
*✓ 57	ACG-45	O-Ring
58	AC-0032	Valve plate assembly (includes valves, restrictors & screws)
*✓ 59	SSG-8156	O-ring
* 60	---	Connecting rod assembly
* 61	---	Cylinder sleeve (position locating mark toward motor)
*✓ 62	M0-9086	Motor
65	AC-0140	Eccentric Flywheel Bearing Assy.
66	SSF-615	Screw (1/4-20 unc-2A)
67	AC-0108	Fan
69	SSF-586	Screw (1/4-20 unc x .75)
70	SSF-3158-1	Screw 10-24 X .75 T25 Torx
*✓ 71	---	Connecting Rod Cap
*✓ 72	---	Compression Ring

NOT ILLUSTRATED

D26368	General Manual
D20005	Parts Manual

- + KK-4981 (also includes Key Nos. 50, 51, 52, 53)
- * KK-4835 piston/cylinder kit (also includes Key Nos. 57, 59, 60, 61, 70, 71, 72)
- ✓ K-0058 cylinder sleeve/compression ring kit (also includes 57, 59, 61, 70, 72)