

IRF3520-1

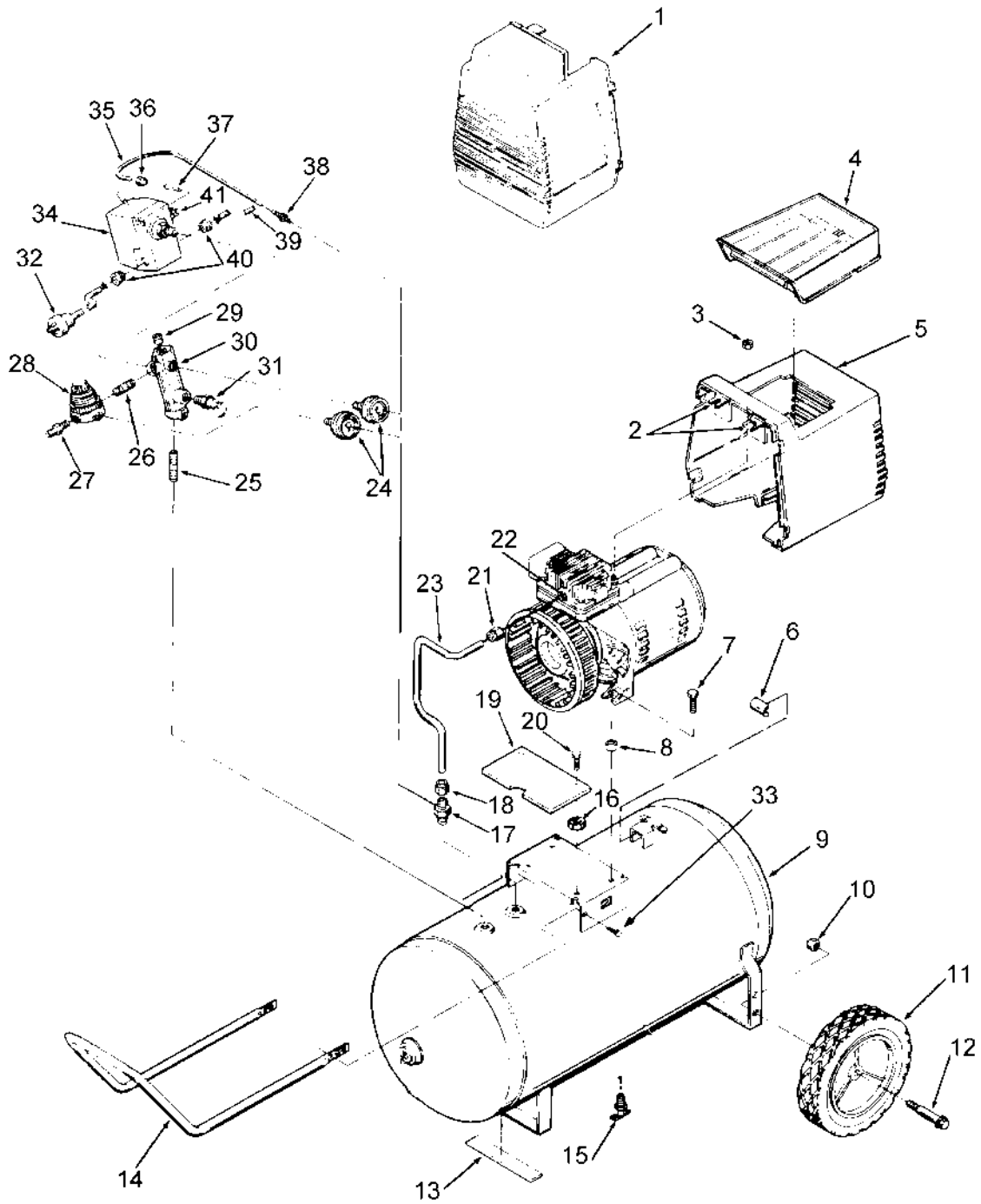

F3520-1

FC3520-1 (cont'd)

KEY NO.	PART NUMBER	DESCRIPTION
1	AC-0049	Shroud, Rear
2	CAC-0077	Shroud, Front
3	CAC-1121	Bracket (2 used)
4	CAC-1080	Tool Tray
5	SS-655-ZN	Hex Nut 1/4" - 20 (2 used)
12	AC-0011	Console, Cover
13	CAC-61	Ring, Panel Mounting
14	AC-0009-1	Gauge, RT Hand
15	AC-0010-1	Gauge, LT Hand
16	AC-0027-2	Manifold
17	SSP-480	Nipple, 1/4 x 2.5"
18	CAC-4290-3	Check Valve
20	AC-0007	Regulator
21	SSG-3105	Silicone Sleeve
22	H-2101	Adaptor
23	SSP-7813	Nut/Sleeve Assy.
24	AC-0008	Pressure Switch
25	SS-8553	Connector Body
26	SSP-7811	Nut/Sleeve Assy. (2 used)
27	AC-0160	Pressure Relief Tube
28	SUDL-413-2	Cord Assembly
29	CAC-1083-1	Outlet Tube
30	SSP-7821-1	Nut Brass Compression (3 used)
31	97503734	Safety Valve
32	91895680	Screw, 1/4-20 x .75 (2 used)
33	ACG-18	Cup, Saddle Mount (2 used)
35	ACG-19	Isolator (3 used)
36	SSF-953-ZN	Screw 10 x 5/8 (2 used)
37	AC-0047	Shroud Plate
40	SS-2707	Drain Valve
41	SUDL-6-1	Strip, Rubber Foot
42	CAC-60	Shoulder Bolt (2 used)
43	AC-0014	Wheel - 9" (2 used)
44	SSF-8080-ZN	Nut, Hex 3/8-16 unc - 2B (2 used)
45	AC-0563	Handle
46	SSF-981	Screw (4 used)

F3520-1 FC3520-1 (cont'd)

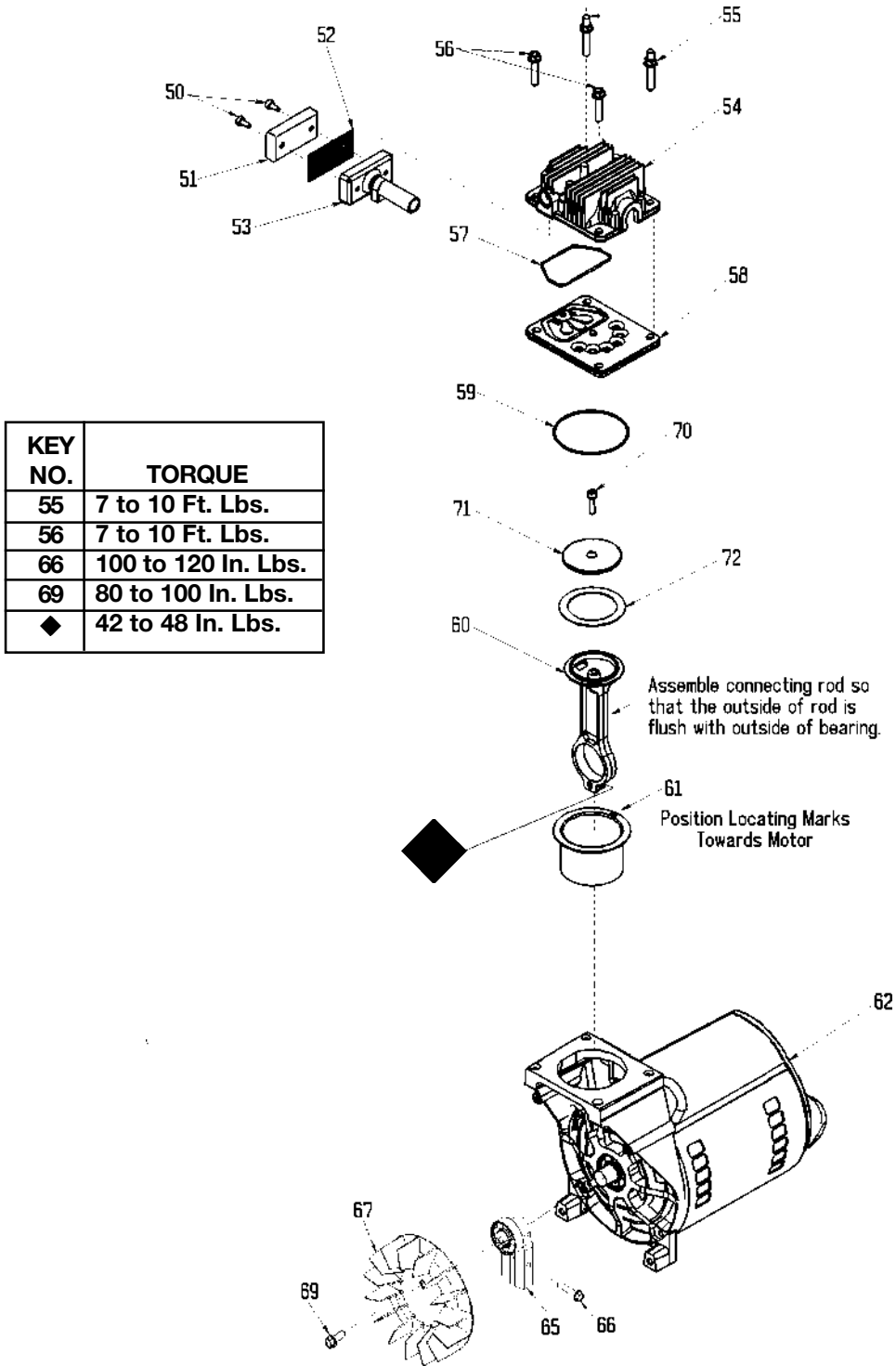

F3520-1

FC3520-1 (cont'd)

KEY		
NO.	PART NUMBER	DESCRIPTION
* 50	-----	Air filter fastener (2 used)
51	DAC-143	Air filter
* 52	-----	Muffler screen
* 53	-----	Intake muffler
54	ACG-26	Head
55	SSF-6640	Stud 1/4"-20 x 1 1/4"
56	SSF-990	Screw 1/4-20 x 1 1/4"
+✓ 57	ACG-45	O-Ring
58	Z-ACG-402	Valve plate assembly (includes valves, restrictors & screws)
+✓ 59	SSG-8156	O-ring
+ 60	-----	Connecting rod assembly
+✓ 61	-----	Cylinder sleeve (position locating mark toward motor)
62	Z-M0-9045	Motor
65	Z-AC-4086	Eccentric Flywheel Bearing Assy.
66	SSF-3153	Screw 1/4-20 unc-2A
\ 67	-----	Fan
\ 68	-----	Washer
\ 69	SSF-3155	Screw 1/4-20 unc x .75
+✓ 70	SSF-3158-1	Screw 10-24 X .75 T25 Torx
+ 71	-----	Compression Ring Connecting Rod Cap
+✓ 72	-----	Compression Ring

NOT ILLUSTRATED

H-7038	Air Hose
SSH-20	Air Chuck
H-7040-1	Air Hose
KK-4315	Pressure Relief Valve
MG2-OFTANK-4A	General Manual
MP2-F3520-2	Parts Manual

+ Keys 57, 59, 60, 61, 70, 71 and 72 can only be purchased as part of KK-4835 Connecting Rod Kit.

* Keys 50, 52 and 53 can only be purchased as part of KK-4981 (also includes Key #51).

\ Keys 67, 68 and 69 can be purchased as part of KK-5018 Fan Kit.

✓ Keys 57, 59, 61, 70 and 72 can be purchased as part of K-0058 Cylinder Sleeve/Compression Ring Kit.