

# PARTS MANUAL FOR OIL LUBRICATED AIR COMPRESSOR



## MODEL NO. IR5E20AD

### SPECIFICATION CHART

Model No.	5E30AD	5E20AD
Horsepower	5	5
Displacement CFM	15.2	15.2
Bore	2 7/8"	2 7/8"
Stroke	2"	2"
Voltage-Single Phase	240	240
Minimum Branch Circuit Requirement	15 amp	15 amp
*Fuse Type	Fusetron Type "T"	Fusetron Type "T"
Air Tank Capacity	30 gal. ASME	20 gal. ASME
Approximate Cut-in Pressure	100 PSIG	100 PSIG
Approximate Cut-out Pressure	125 PSIG	125 PSIG
SCFM @ 90 psig	10.2	10.2
SCFM @ 40 psig	12.2	12.2
U.L. Listed	Yes	Yes

\*A circuit breaker is preferred. Use only a fuse or circuit breaker that is the same rating as the branch circuit the air compressor is operated on. If the air compressor is connected to a circuit protected by fuses, use dual element time delay fuses (Buss Fusetron Type "T" only).

# Air Compressor Diagram

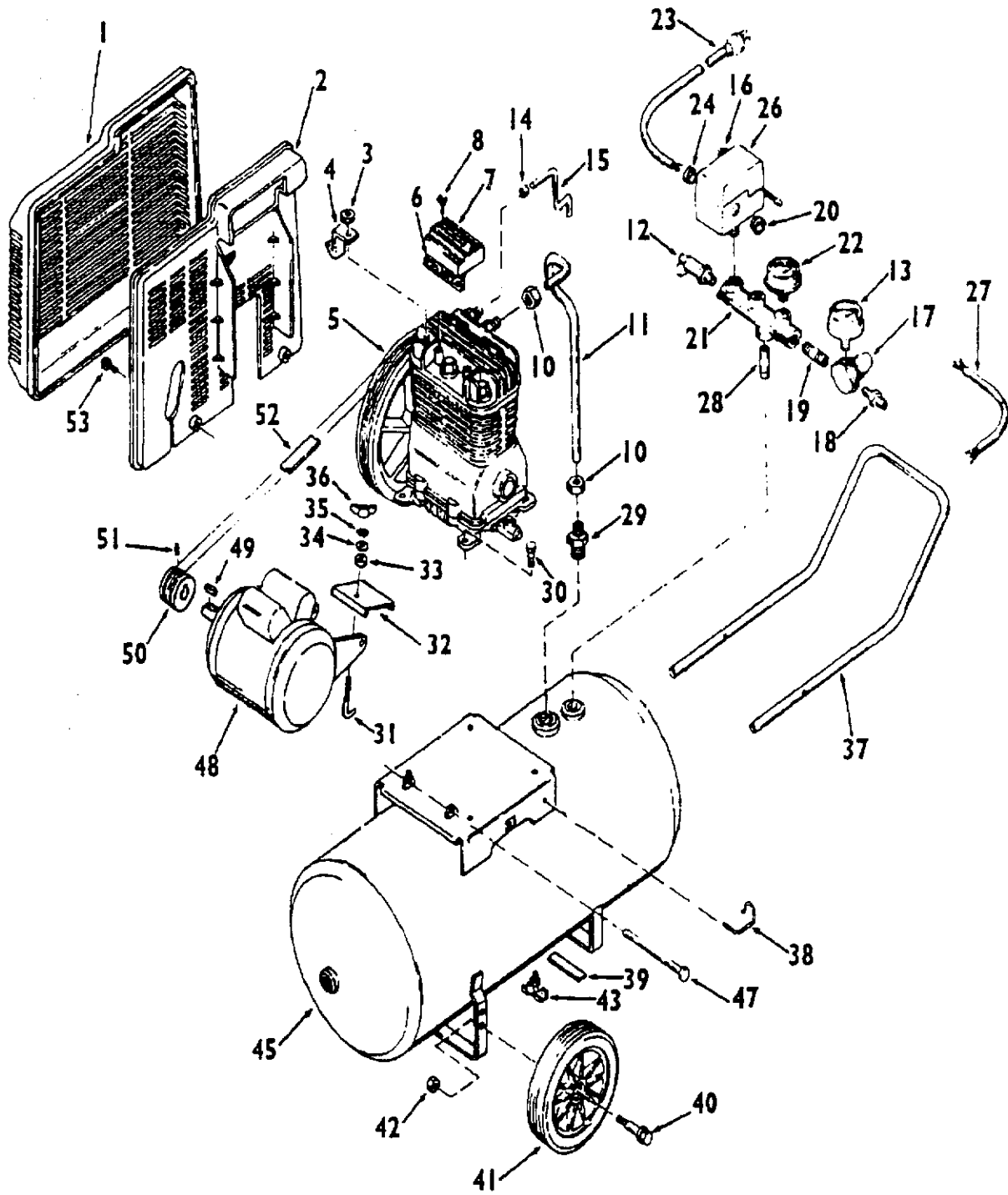

# Parts List

KEY NO.	PART NUMBER	DESCRIPTION
1	CAC-322	Belt guard, outside
2	CAC-323	Belt guard, inside
3	SSF-8113-ZN	Lock nut
4	CAC-327	Bracket
5	CAC-4003-1	Compressor Pump Assy.
✓ 6	265-17	Intake filter
7	CAC-356	Filter retainer
8	SSF-935	Screw, #8-32 x 3/8" (2 used)
10	SSP-7812	Nut Sleeve Assy. 1/2" (2 used)
11	CAC-1104	Outlet tube
12	TIA-4150	Safety valve ASME
13	C-GA-345	Pressure gauge
14	SSP-7811	Nut Sleeve Assy. 1/4" (2 used)
15	CAC-1105	Pressure release tube
16	KK-4315	Pressure release valve and mounting nut (included with #26)
17	CAC-4296	Pressure regulator
18	H-2099	Adapter
19	SS-2071	Nipple
20	SSW-7367	Strain relief
21	CAC-95	Manifold
22	C-GA-346	Gauge
23	SUDL-415-1	Cord Assembly
24	SSW-7385	Strain Relief
26	CAC-4221-1	Pressure switch
27	CAC-4241-1	Motor cord assembly
28	SS-2072	Nipple
29	CAC-437-2	Check valve
30	SSF-928	Screw 5/16"-18 x 7/8" (4 used)
31	CAC-1013	Hold-down screw
32	CAC-1012	Hold-down plate
33	CAC-1011	Elastomer spring
34	SSN-56-ZN	Washer
35	SSN-1619-ZN	Lockwasher
36	SS-2038-ZN	Wing nut
37	CAC-1159	Handle
38	CAC-1059	Retaining clip (2 used)
39	SUDL-6-1	Rubber foot strip
40	CAC-60	Shoulder bolt (2 used)
41	CAC-4313	10" wheel (2 used)
42	SSF-8080-ZN	Nut (2 used)
43	SS-2707	Drain cock
45	TA-4224	Air tank, 30 gallon ASME
	TA-4223	Air tank, 20 gallon ASME
47	CAC-287	Motor pin
48	C-MO-3013	Motor
49	SUDL-65	Motor shaft key (3/16" x 3/16" x 1 1/4")
50	C-PU-2861	Motor pulley
51	SS-391	Set screw
52	C-BT-223	Poly-V-Belt, 39" long
53	SSF-986	Self-tapping screw (2 used)

Kit  
KK-4820

# Compressor Pump Diagram

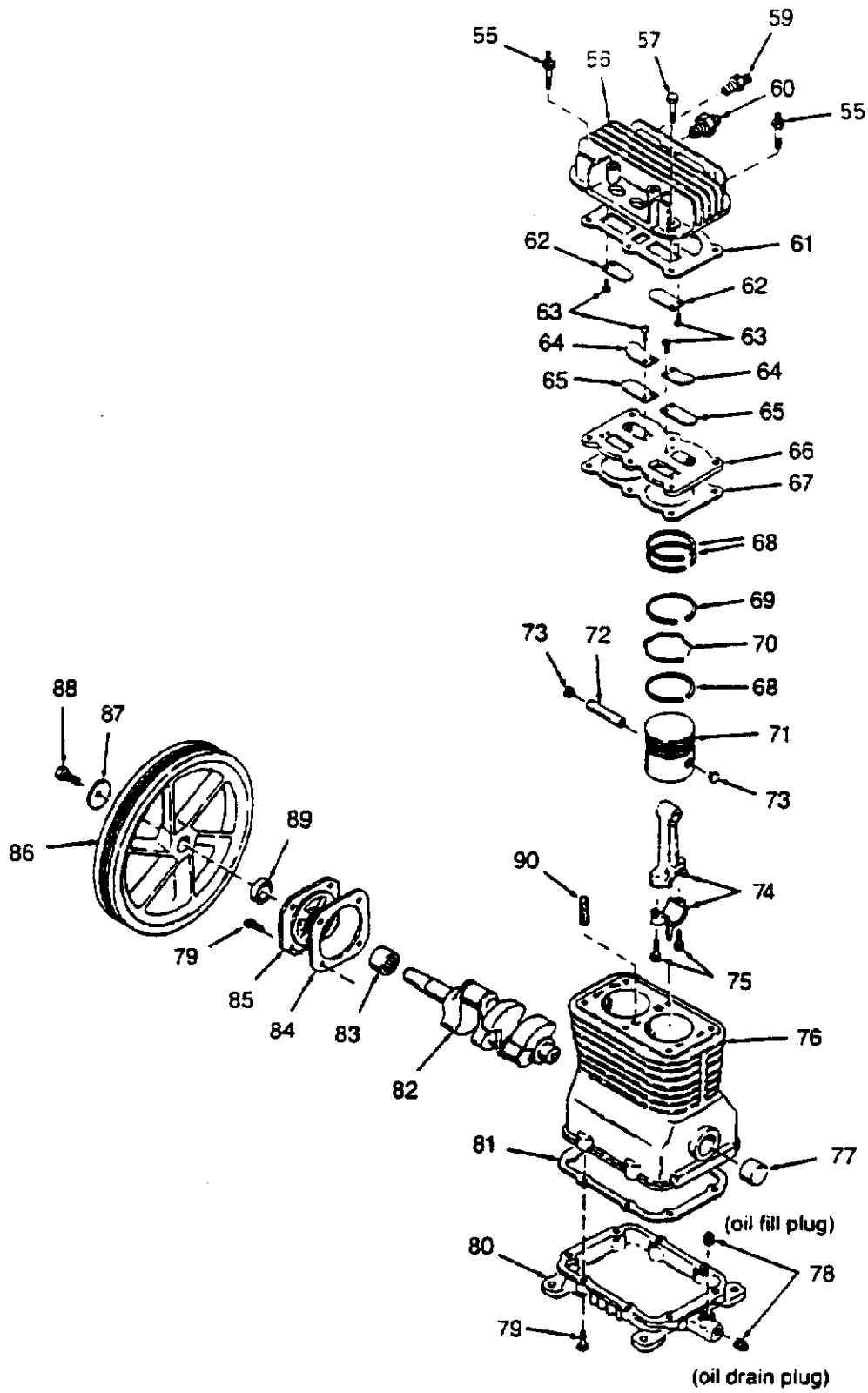

# Parts List

KEY NO.	PART NUMBER	DESCRIPTION
55	SSF-6627	Stud 3/8"-16 both ends (1 used)
56	CAC-293	Head
57	SSF-955	Screw, 3/8"-16 x 1 1/2" (5 used)
59	SS-8553	Adapter
60	SSP-9401	Adapter
✓ 61	CAC-291	Head gasket
● 62	265-25	Intake flapper valve - square corners (2 used on head) <span style="float: right; border: 1px solid black; padding: 2px;">o o</span>
● 63	SSF-9821	Screw #5-40 x 1/4" (8 used)
64	CAC-294	Restrictor plate (2 used)
● 65	265-196	Exhaust flapper valve - beveled corners (2 used on valve plate) <span style="float: right; border: 1px solid black; padding: 2px;">o o</span>
66	CAC-289	Valve plate
✓ 67	CAC-54-1	Valve plate gasket
+ 68	CAC-56	Compression ring (4 used)
+ 69	CAC-58	Oil ring (4 used)
+ 70	CAC-57	Oil ring expander (2 used)
71	CAC-55	Piston (2 used)
72	265-19	Piston pin (2 used)
73	CAC-207	Piston pin plug (4 used)
74	265-410	Connecting rod assembly (2 used) Includes (2) SSF-927 screws (Key #75)
75	SSF-927	Screw, 1/4"-20 x 1 1/8" (4 used)
76	CAC-51	Crankcase and cylinder
77	265-41	Needle bearing
78	SSP-1413	Pipe plug (2 used)
79	SSF-925	Screw, 1/4"-20 x 7/8" (12 used)
80	265-3	Base
✓ 81	265-16	Base gasket
82	CAC-373	Crankshaft
83	265-23	Needle bearing
✓ 84	265-13	End plate gasket
85	265-9	End plate
86	265-2	Flywheel
87	SSN-1014-ZN	Belleville washer
88	SSF-3039-ZN	Cap screw
✓ 89	265-111	Seal
✓ 90	265-6	Vent filter
		NOT ILLUSTRATED
	SSH-8	Air chuck
	H-5796	Air hose assembly (1/4" I.D. x 15')

+ Key No. 68, 69 and 70 only available as part of Ring Kit KK-4313.

✓ Key No. 6, 61, 67, 81, 84, 89 and 90 available as individual parts or part of Gasket Kit KK-4312-2.

● Key No. 62, 63 and 65 only available in Valve Kit KK-4275.

### Recommended Oils - One Stage Compressor Units

Use a compressor oil such as SAE 20-20W SF motor oil. (Crankcase oil capacity is 16 fluid ounces.) Under extreme winter conditions use 10 weight oil. Multiviscosity oil, 10W30, will leave carbon deposits on critical components, reducing performance and compressor life.