

# F312-5

KEY NO.	TORQUE
5	50 to 60 In. Lbs
30	100 to 120 In. Lbs.
36	60 to 75 In. Lbs.

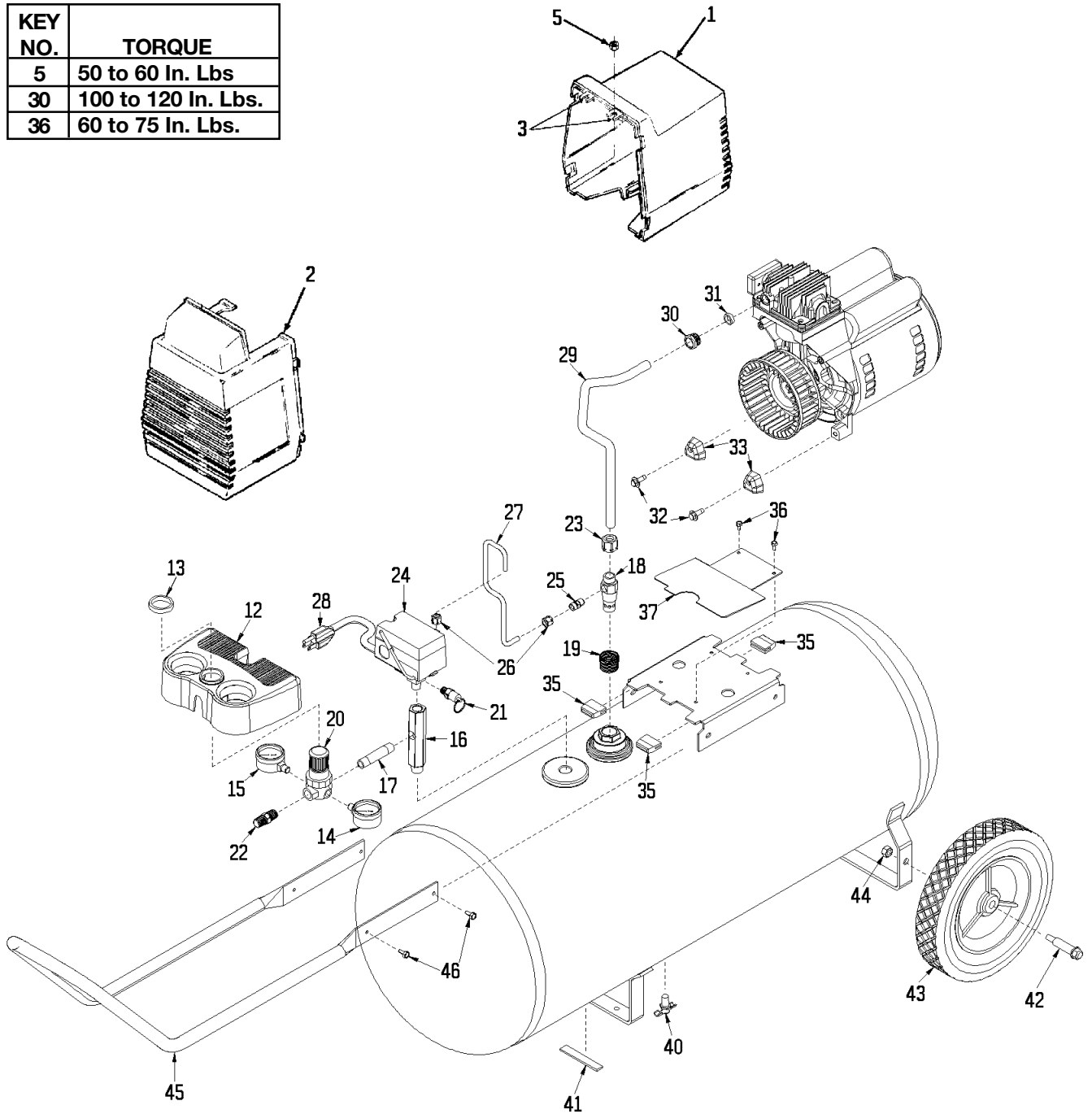

# F312-5 (cont'd)

<b><u>KEY NO.</u></b>	<b><u>PART NUMBER</u></b>	<b><u>DESCRIPTION</u></b>
1	AC-0055	Shroud, Rear
2	AC-0078	Shroud, Front
3	CAC-1121	Bracket (2 used)
4	CAC-1080	Tool Tray
5	SS-655-ZN	Hex Nut 1/4" - 20 (2 used)
12	AC-0011	Console, Cover
13	CAC-61	Ring, Panel Mounting
14	AC-0009-1	Gaugle, RT Hand
15	AC-0010-1	Gauge, LT Hand
16	AC-0027-2	Manifold
17	SSP-480	Nipple, 1/4 x 2.5"
18	CAC-4290-3	Check Valve
19	SSP-490	Reducer
20	AC-0007	Regulator
21	97503734	Safety Valve
22	H-2101	Adaptor
23	SSP-7813	Nut/Sleeve Assy.
24	AC-0008-2	Pressure Switch
25	SS-8553	Connector Body
26	SSP-7811	Nut/Sleeve Assy. (2 used)
27	AC-0160	Pressure Relief Tube
28	SUDL-403-1	Cord Assembly
29	AC-0125	Outlet Tube
30	SSP-7821-1	Nut Brass Compression (3 used)
31	SSG-3105	Silicone Sleeve
32	91895680	Screw, 1/4 - 2 ounce - 2A THD Forming (2 used)
33	ACG-18	Cup, Saddle Mount (2 used)
35	ACG-19	Isolator (3 used)
36	SSF-953-ZN	Screw 10 x 5/8 (2 used)
37	AC-0047	Shroud Plate
40	SS-2707	Drain Valve
41	SUDL-6-1	Strip, Rubber Foot
42	CAC-60	Shoulder Bolt (2 used)
43	AC-0014	Wheel - 6" (2 used)
44	SSF-8080-ZN	Nut, Hex 3/8" (2 used)
45	AC-0563	Handle
46	SSF-981	Screw (4 used)

# F312-5 (cont'd)

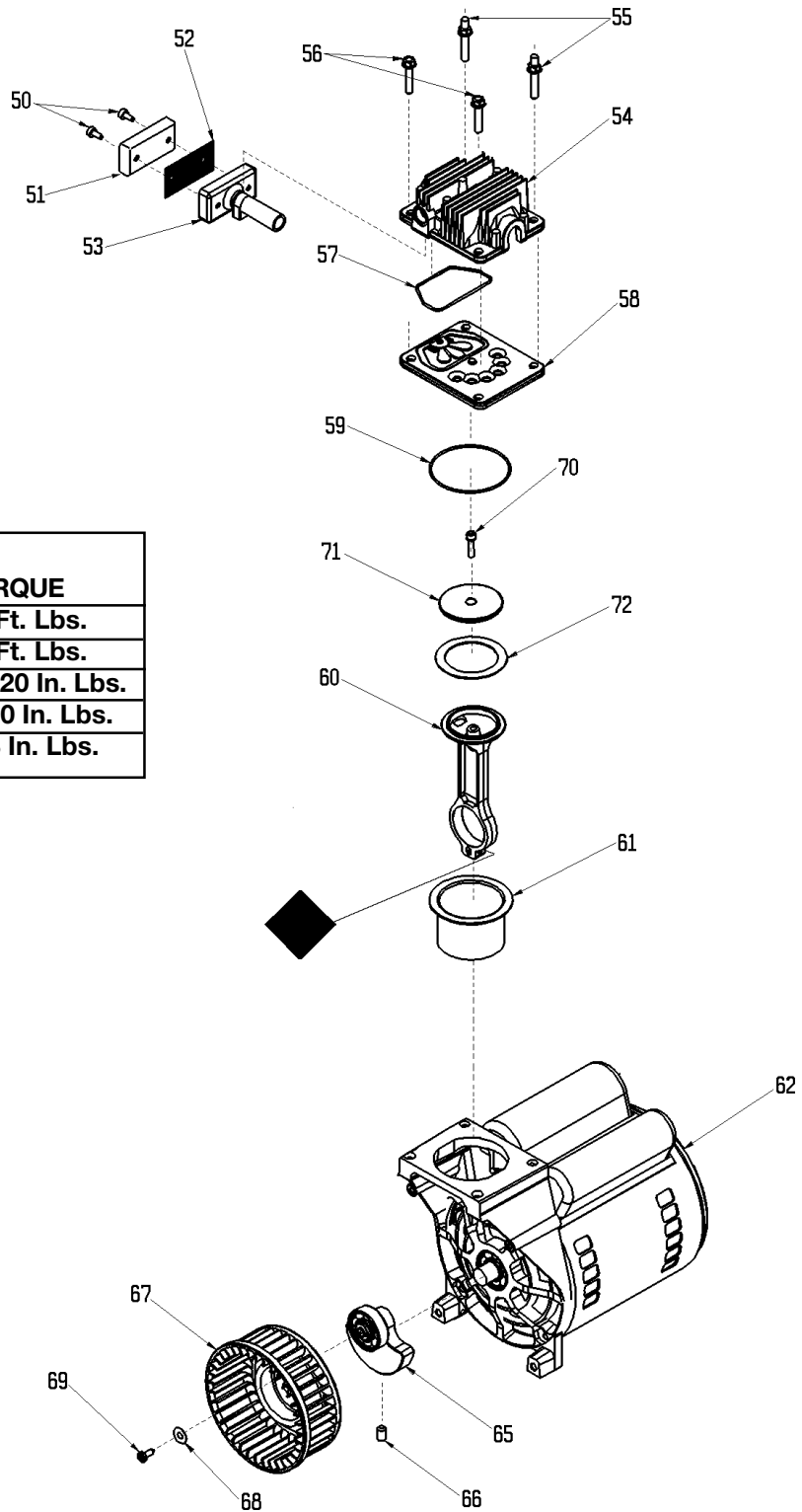

KEY NO.	TORQUE
55	7 to 10 Ft. Lbs.
56	7 to 10 Ft. Lbs.
66	100 to 120 In. Lbs.
69	80 to 100 In. Lbs.
◆	42 to 48 In. Lbs.

# F312-5 (cont'd)

<b>KEY NO.</b>	<b>PART NUMBER</b>	<b>DESCRIPTION</b>
+ 50	---	Air filter fastener (2 used)
51	DAC-143	Air filter
+ 52	---	Muffler screen
+ 53	---	Intake muffler
54	ACG-26	Head
55	SSF-6640	Stud 1/4"-20 x 1 1/4"
56	SSF-990	Screw 1/4-20 x 1 1/4"
*✓57	ACG-45	O-Ring
58	Z-ACG-402	Valve plate assembly (includes valves, restrictors & screws)
*✓59	SSG-8156	O-ring
* 60	---	Connecting rod assembly
*✓61	---	Cylinder sleeve (position locating mark toward motor)
62	Z-M0-9045	Motor
65	Z-CAC-4086	Eccentric Flywheel Bearing Assy.
66	SSF-3153	Screw
X 67	-----	Squirrel Cage Fan (also includes one of #69)
67	AC-0108	Alternate Cooling Fan
X 68	-----	Washer
X 69	-----	Screw 1/4-20 unc x .75
*✓70	SSF-3158-1	Screw 10-24 X .75 T25 Torx
* 71	---	Compression Ring Connecting Rod Cap
*✓72	---	Compression Ring

## **NOT ILLUSTRATED**

H-7038	Air Hose
SSH-20	Air Chuck
KK-4315	Pressure Relief Valve
MG2-OFTANK-4A	<b>General Manual</b>
MP2-F312-5A	<b>Parts Manual</b>

- + Keys 50, 52 and 53 can only be purchased as part of KK-4977 (also includes Key #51).
- \* Keys 57, 59, 60, 61, 70, 71, and 72 are purchased as part of KK-4835 piston/cylinder kit.
- ✓ Keys 57, 59, 70 and 72 can be purchased as part of K-0058 cylinder sleeve/compression ring kit.
- X Keys 67, 68 and 69 can only be purchased as part of KK-5018. The AC-0108 fan can also be substituted for this part.