

# INSTALLATION INSTRUCTIONS

**WARNING: IMPROPER INSTALLATION, ADJUSTMENT, ALTERATION, SERVICE OR MAINTENANCE CAN CAUSE INJURY OR PROPERTY DAMAGE. REFER TO THIS MANUAL. FOR ASSISTANCE OR ADDITIONAL INFORMATION CONSULT A QUALIFIED INSTALLER, SERVICE AGENCY OR THE GAS SUPPLIER.**

**WARNING: THE \_DVR6 SERIES FIREPLACES ARE DIRECT VENT DECORATIVE GAS APPLIANCES. DO NOT BURN WOOD OR OTHER MATERIAL IN THESE APPLIANCES.**

**WARNING: AT THE BEGINNING OF EACH HEATING SEASON HAVE THE GLASS DOOR GASKET INSPECTED FOR PROPER SEALING BY A QUALIFIED SERVICE TECHNICIAN.**

*Formerly Identified As Models*

*\_DVR-38RMN    \_DVR-38REN  
\_DVR-38RMP    \_DVR-38REP  
\_DVC-38RMN    \_DVC-38REN  
\_DVC-38RMP    \_DVC-38REP*

**Models Covered in This Document  
Are Part Of Superior's  
DVR-6000 SERIES**

## *Installation And Operating Instructions*

*For Direct Vent  
Decorative Gas  
Appliances*

*Millivolt Models  
\_DVR6-RMNS  
\_DVR6-RMPS  
\_DVR6-CMNS  
\_DVR6-CMPS*

*Electronic Models  
\_DVR6-RENS  
\_DVR6-REPS  
\_DVR6-CENS  
\_DVR6-CEPS*

*And Vent System  
Accessories  
\_DSF5-24  
\_DST5-12/18  
\_DST5-45ELB  
\_DST5-HTK  
\_DV-HTK  
\_DST5-EXT  
\_DST5-FSV  
\_DST5-VTK  
\_DV-ARK*

## FOR YOUR SAFETY

What to do if you smell gas:

- DO NOT light any appliance.
- DO NOT touch any electrical switches.
- DO NOT use any phone in your building.
- Immediately call your gas supplier from a neighbor's phone.
- If your gas supplier cannot be reached, call the fire department.

## FOR YOUR SAFETY

Do not store or use gasoline or other flammable vapors or liquids in the vicinity of this or any other appliance.

Due to high temperatures, the appliance should be located out of traffic and away from furniture or drapes. Do not place clothing or other materials on or near the appliance.

PLEASE RETAIN THIS MANUAL FOR FUTURE REFERENCE.



IAS Report No. L2970004

## TABLE OF CONTENTS

Introduction .....	page 2
General Information .....	page 3
Location .....	page 3
Clearances .....	page 3
Appliance Specifications .....	page 4
Framing Specifications .....	page 4
Exterior Vent Clearances .....	page 5
Assembly Steps .....	page 6
Installation .....	page 6
Standard Venting .....	page 7
Extended Venting .....	page 7
Vent Installation .....	page 7
Vertical Venting .....	page 9
Wiring .....	page 11
Connecting Gas Line .....	page 13
High Elevation Derating .....	page 13
Installing Logs and Rockwool .....	page 13
Appliance Operation .....	page 14
Millivolt Appliance Checkout .....	page 14
Electronic Appliance Checkout .....	page 14
Installing Glass Door Frame .....	page 14
Burner Adjustments .....	page 15
Finishing Requirements .....	page 15
Cold Climate Insulation .....	page 16
Direct Vent Series Options .....	page 16
Gas Conversion Kits .....	page 18
Operation/Care of Your Appliance .....	page 19
Maintenance .....	page 19
Gasket Inspection .....	page 19
Warranty .....	page 20
Replacement Parts .....	page 20
Accessories/Components .....	page 20
Lighting Instructions - Millivolt .....	page 24
Lighting Instructions - Electronic .....	page 26
Replacement Parts List - Millivolt .....	page 28
Replacement Parts List - Electronic .....	page 30
Troubleshooting Guide - Millivolt .....	page 32
Troubleshooting Guide - Electronic .....	page 33

This installation manual will help you obtain a safe, efficient, dependable installation for your appliance and vent system. Please read and understand these instructions before beginning your installation.

## INTRODUCTION

The \_DVR6 Series are sealed combustion, air circulating, vented decorative gas appliances designed for residential applications. These appliances must be installed with either the \_DST5 or \_DSF5 vent system that is routed horizontally or vertically to the outside atmosphere. Optional extended vent routing can include up to three (3) 90 degree elbows or six (6) 45 degree elbows.

The -CM and -RM (millivolt) appliances are designed to operate on natural or propane gas. A millivolt gas control valve with piezo ignition system provides safe, efficient operation. External electrical power is required to operate the optional blower if installed; electrical power must be wired during appliance installation.

The -CE and -RE (electronic) appliances are designed to operate on natural or propane gas. An electronic direct spark ignition system provides safe, efficient operation. External electrical power is required to operate these units.

These appliances comply with National Safety Standards and are tested and listed by IAS (Report No. L2970004) to ANSI Z21.50 - 1996 (in Canada, CAN/CGA-2.22-M96 and CAN/CGA-2.17-M91) as vented gas fireplaces.

Installation must conform to local codes. In the absence of local codes, installation must comply with the current National Fuel Gas Code, ANSI Z223.1. (In Canada, the current CAN-1 B149 installation code.) Electrical wiring must comply with the National Electrical Code ANSI/NFPA 70 - (latest edition). (In Canada, the current CSA C22-1 Canadian Electrical Code.)

**DO NOT ATTEMPT TO ALTER OR MODIFY THE CONSTRUCTION OF THE APPLIANCE OR ITS COMPONENTS. ANY MODIFICATION OR ALTERATION MAY VOID THE WARRANTY, CERTIFICATION AND LISTINGS OF THIS UNIT.**

## TYPICAL INSTALLATION

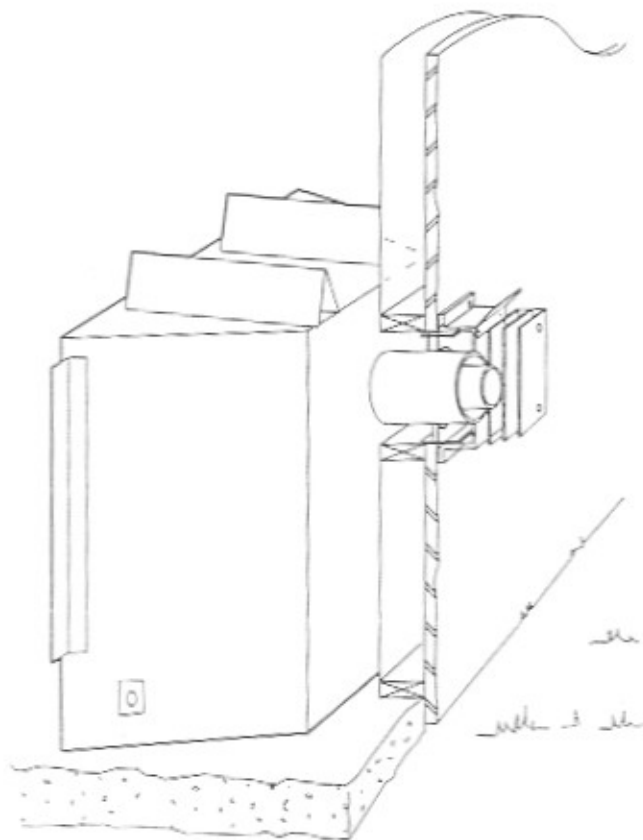

Figure 1

NOTE: DIAGRAMS & ILLUSTRATIONS NOT TO SCALE.

## GENERAL INFORMATION

*Note: Installation and repair should be performed by a qualified service technician. The appliance should be inspected annually by a qualified professional service technician. More frequent inspections and cleanings may be required due to excessive lint from carpeting, bedding material, etc. It is imperative that the control compartment, burners and circulating air passage ways of the appliance be kept clean.*

Provide adequate clearances around air openings and adequate accessibility clearance for service and proper operation. Never obstruct the front openings of the appliance.

These appliances are designed to operate on natural or propane gas only. The use of other fuels or combination of fuels will degrade the performance of this system.

Input of appliance is 28,000 BTU/HR for natural gas and 27,000 BTU/HR for propane gas.

Do not use these appliances if any part has been under water. Immediately call a qualified service technician to inspect the appliance and to replace any parts of the control system and any gas control which have been under water.

Test gage connections are provided on the front of the millivolt gas control valve (identified IN for the inlet and OUT for the manifold side). A 1/8" NPT test gage connection is provided on the electronic gas control valve adjacent to the outlet to the main burner.

Minimum inlet gas pressure to the appliance is 4.5 inches water column for natural gas and 11 inches water column for propane for the purpose of input adjustment.

Maximum inlet gas supply pressure to the appliance is 7.0 inches water column for natural gas and 13.0 inches water column for propane.

The appliance must be isolated from the gas supply piping system (by closing its individual manual shut-off valve) during any pressure testing of the gas supply piping system at test pressures equal to or less than 1/2 psig (3.5 kPa).

The appliance and its individual shut-off valve must be disconnected from the gas supply piping system during any pressure testing of that system at pressures in excess of 1/2 psig (3.5 kPa).

These appliances must not be connected to a chimney or flue serving a separate solid fuel burning appliance.

Do not place clothing or other materials on or near this appliance.

## LOCATION

In selecting the location, the aesthetic and functional use of the appliance are primary concerns. However, vent system routing to the exterior and access to the fuel supply are also important. Consideration should be given to traffic ways, furniture, draperies, etc., due to elevated surface temperatures. The location should also be free of electrical, plumbing or other heating/air conditioning ducting.

All of the direct vent appliances are uniquely suited for installations requiring a utility shelf positioned directly above the fireplace. Utility shelves like these are commonly used for locating television sets and decorative plants. To provide for the lowest possible shelf surface, combustible materials used to support a utility shelf directly above these appliances should be positioned just above the appliance top spacers. The minimum height from the base of the appliance to the underside of combustible materials used to construct a utility shelf is 39 1/2" (1003 mm).

The appliance should be mounted on a fully supported base extending the full width and depth of the unit. The appliance may be located on or near conventional construction materials. However, if installed on combustible materials, such as carpeting, vinyl tile, etc., a metal or wood barrier covering the entire bottom surface must be used.

All \_DVR6 appliances covered in this manual are listed for bedroom use.

## Mobile Home Installation

These fireplaces are listed for use in Mobile Homes.

## Clearances

Minimum clearance to combustibles are:

Appliance: side and back - 0"  
floor - 0"  
adjacent wall - 0"  
ceiling - 37 1/2" (953 mm)

Vent: top - 11" (279 mm)  
sides - 1" (25 mm)  
bottom - 1" (25 mm)

Outside Wall Framing at Termination:  
top - 3" (76 mm)  
sides - 2" (51 mm)  
bottom - 1" (25 mm)

The standard horizontal vent termination must have a minimum of 3" (76 mm) clearance to any overhead combustible projection of 2 1/2" (64 mm) or less. Maintain 12" (305 mm) clearance from projections exceeding the 2 1/2" (64 mm) (Figure 2). For additional vent locations restrictions refer to Figure 7.

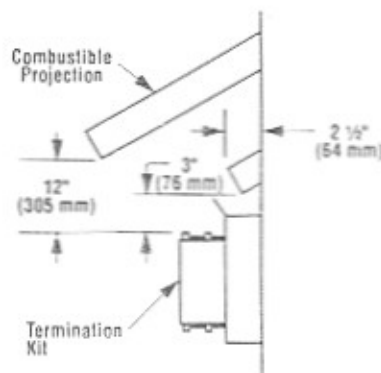
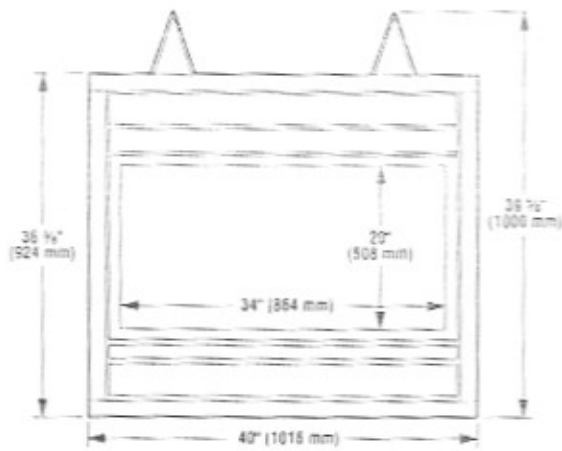
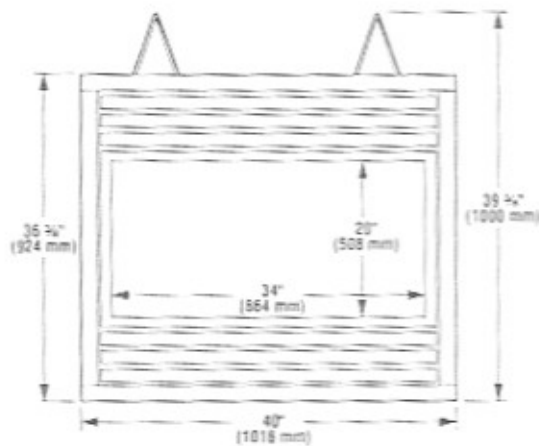

Figure 2

## APPLIANCE SPECIFICATIONS



Front View  
(DVR6-R)



Front View  
(DVR6-C)

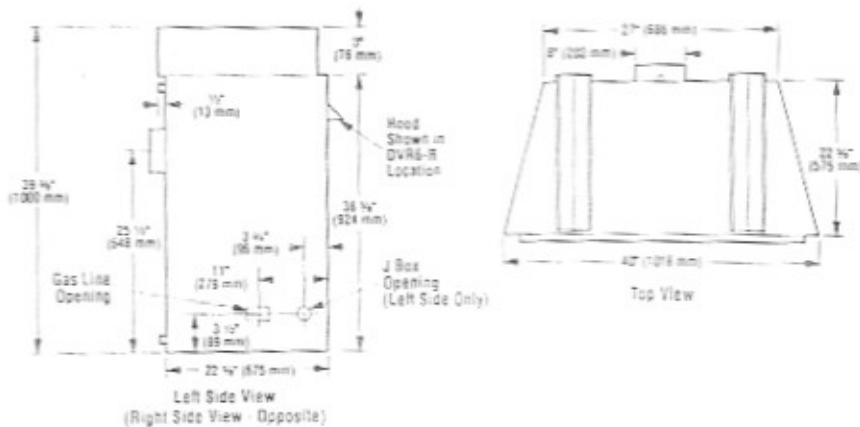

Figure 3

## FRAMING SPECIFICATIONS

Note: Framing dimensions are calculated for a nailing flange depth of 1/2"

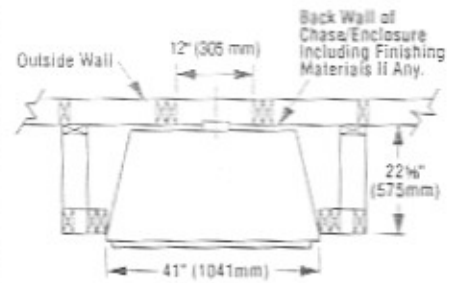

Figure 4

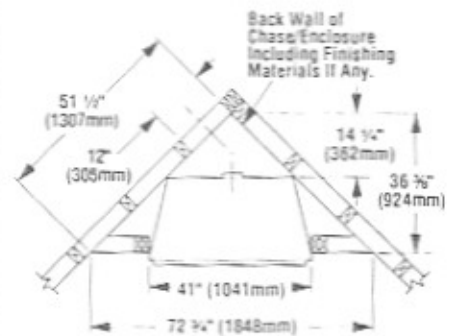

Figure 5

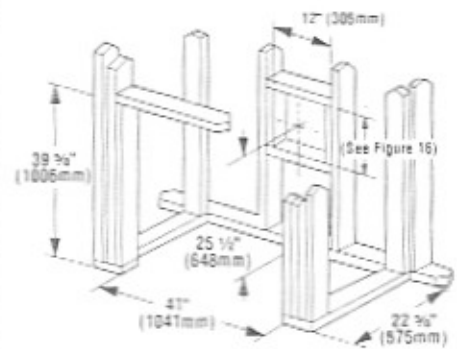
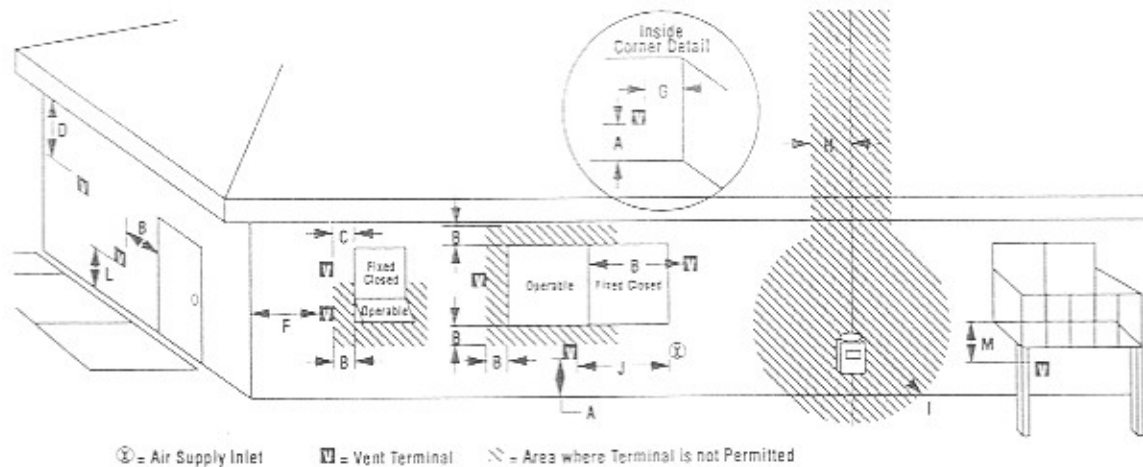

Figure 6

## EXTERIOR VENT CLEARANCE REQUIREMENTS



- |   |   |
|---|---|
| <p><b>A</b> = clearance above grade, veranda, porch, deck, or balcony<br/>12 inches (30 cm) minimum</p> <p><b>B</b> = clearance to window or door that may be opened<br/>U.S. - 9 inches (22.5 cm) minimum<br/>Canada - 12 inches (30 cm) minimum</p> <p><b>C</b> = clearance to permanently closed window - recommended to prevent condensation on window<br/>U.S. - 9 inches (22.5 cm) minimum<br/>Canada - 12 inches (30 cm) minimum</p> <p><b>D</b> = vertical clearance to soffit located above the terminal<br/>ventilated soffit 18 inches (46 cm) minimum<br/>unventilated soffit 12 inches (30 cm) minimum</p> <p><b>F</b> = clearance to outside corner<br/>9 inches (23 cm) minimum</p> <p><b>G</b> = clearance to inside corner<br/>6 inches (15.2 cm) minimum</p> <p><b>H</b> = not be installed above a gas meter/regulator assembly or within 3 feet (90 cm) horizontally from the center line of the regulator.</p> | <p><b>I</b> = clearance to gas service regulator vent outlet<br/>U.S. - 3 feet (90 cm) minimum<br/>Canada - 6 feet (1.8 m) minimum</p> <p><b>J</b> = clearance to air supply inlet to building or the combustion air inlet to any other appliance.</p> <p>non-mechanical inlet:<br/>U.S. - 9 inches (22.5 cm) minimum<br/>Canada - 12 inches (30 cm) minimum</p> <p>mechanical air supply:<br/>6 feet (1.8 m) minimum</p> <p><b>L</b> = clearance above paved sidewalk or paved driveway located on public property<br/>7 feet (2.1 m) minimum</p> <p><i>Note: A vent shall not terminate directly above a sidewalk or paved driveway which is located between two (2) single family dwellings and serves both dwellings.</i></p> <p><b>M</b> = clearance under veranda, porch, deck, or balcony where fully open on a minimum of two (2) sides beneath the floor<br/>12 inches (30 cm) minimum</p> |
|---|---|

*Note: Check local codes or regulations for variations.*

Figure 7

## ASSEMBLY STEPS

The typical sequence of installation follows; however, each installation is unique resulting in variations to those described.

1. Construct the appliance framing.
2. Route gas supply line to appliance location.
3. Remove and affix nailing flanges to the appliance. On \_DVR6-R models install the hood.
4. Position the appliance.
5. Install the vent system and exterior termination.
6. **Millivolt Appliances** – Install the operating control switch and bring in electrical service line for forced air circulating blower (optional equipment).
7. **Electrical Appliances** – Field wire and install operating control switch.
8. Mount forced air blower (optional equipment).
9. Make connection to gas supply.
10. Install the logs and Rockwool.
11. Checkout appliance operation.
12. Install glass door frame assembly.
13. Adjust burner to ensure proper flame appearance.

## INSTALLATION

The appliance is shipped with all gas controls and components installed and pre-wired. Remove the shipping carton, exposing the front glass door frame. Remove wood slats and remove and discard the wood slat mount brackets. Loosen and remove the three (3) 1/2"-20 x 1" Phillips pan head screws at the three (3) tabs located along the door frame top edge. Tilt the glass door frame assembly outward and disengage the three (3) tabs along the bottom of the door from the three (3) brackets at the bottom of the firebox opening. Remove the door and set the panel aside protecting it from inadvertent damage. Retain the three (3) screws for use on reassembly. Remove the logs packaged within the firebox and set aside.

Step 1. Frame appliance enclosure as illustrated in Figures 4 through 6.

**Note:** The framed depth, 22 3/8" (575 mm) from a framed wall, must always be measured from a finished surface. If a wall covering such as drywall is to be attached to the rear wall, then the 22 3/8" (575 mm) must be measured from the drywall surface. It is important that this dimension be exact in order for the vent terminal kit to be connected properly. Similarly, the 36 3/8" (924 mm) (51 1/8" (1307 mm)) framing dimension is important for corner vent connections.

If the appliance is to be elevated above floor level, a solid continuous platform must be constructed.

The header may be in direct contact with the top metal spacers, but must not rest on them or be notched to fit around them.

Step 2. Route a 1/2" (13 mm) gas line along the left or right side framing (Figure 8).

All appliances have a 3' long 3/8" NPT nipple installed at the valve. To quickly and easily complete the gas line routing, use the gas flex line kit, Model \_GFLV.

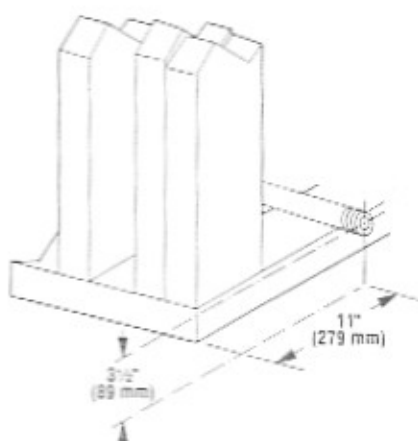

Figure 8

Step 3. Remove the nailing flanges from the lower control compartment and install in place with three (3) screws each. Align with the three holes on each side of the appliance (refer to Figure 9).

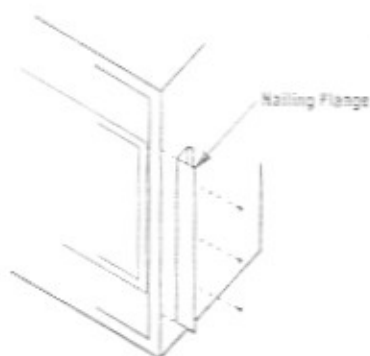

Figure 9

Install the hood on all \_DVR6-R units. Position the hood in the open area just above the appliance door. Locate the flange, found along the top edge of the hood, behind the upper radiant panel. Install the two (2) screws into the holes at the ends of the hood. Secure the hood to the appliance frame by tightening the screws.

Step 4. Position appliance into prepared framing, secure with 6d nails at the nailing flange along each side.

Step 5. **Installing the Venting** – The \_DVR6 Series appliance must be vented directly to the outside through its own double wall pipe assembly, 5" (127 mm) and 8" (203 mm) diameters. The vent system may not service multiple appliances and must never be connected to a flue serving a solid fuel burning appliance.

These appliances are designed, tested and listed for operation with, and only with, \_DST5 and \_DSF5 vent components. DO NOT use other manufacturers' components.

### Listed Vent Components:

_DST5-HTK	– Horizontal termination kit
_DV-HTK	– Horizontal termination kit
_DST5-VTK	– Vertical termination kit*
_DV-ARK	– Air restrictor kit*
_DST5-F	– Flashing and collar*
_DST5-FSV	– Firestop
_DST5-12/18/36	– Vent sections
_DST5-90ELB	– 90° Elbow*
_DST5-45ELB	– 45° Elbow
_DST5-EXT	– Adjustable extension
_DSF5-24	– Flexible vent section
_DVSP5-90ELB	– 90Degree Starter Elbow*

\*Note: These components are for use with extended venting options only.

### Adjustable Extension

The **\_DST5-EXT** vent extension is adjustable from 6" (152 mm) to 9 3/4" (248 mm). Use this component when there is a short distance to complete the vent system in lieu of cutting the uncrimped end of a vent section.

### STANDARD VENTING

Before positioning the appliance, determine the vent routing. These appliances may only be vented horizontally using the **\_DST5-HTK** or **\_DV-HTK** termination. Venting may be through the **\_DST5** vent components or through the **\_DSF5** flexible vent system. When using the **\_DSF5** system alone, only one (1) offset of no more than 45° is allowed.

The **\_DSF5-24** flexible vent section may be used to attach the **\_DST5-HTK** and **\_DV-HTK** terminations directly to the appliance collar. Never use the **\_DSF5-24** unless the end of this component is to be attached directly to the **\_DST5-HTK** or **\_DV-HTK**. The **\_DSF5-24** is designed to be used in place of **\_DST5** vent components. Flex vent ends are secured with provided hose clamps instead of the screws used with the **\_DST5** sections. The inner tube of the **\_DSF5-24** must be sealed at both ends with **\_Mill-Pac Black** (700°F) high temperature sealant. The **\_DSF5-24** must not be bent to an inside diameter smaller than 5" (127 mm) or more than 45° (Figure 10).

*Note: The **\_DSF5-24** vent component is rigid and self supporting; it does not require bracing. Do not allow any materials to be in contact with or rest upon the **\_DSF5-24** in the installation application. Attach the inner and outer flex vent collars to the termination end of the **\_DSF5-24** prior to connecting to the termination. The inner and outer flex vent collars will slide into the telescoping components of the termination.*

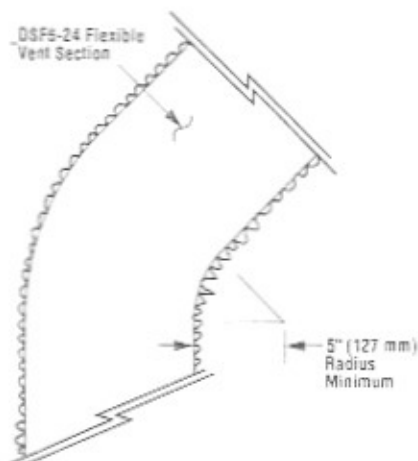

Figure 10

The following paragraphs detail installation using the **\_DST5** components. **\_DSF5** flexible vent is installed in exactly the same way utilizing the provided hose clamps to secure the components together.

When venting directly out the back of the appliance (standard venting) the total vent length for the **\_DVR6**, measured from the back surface of the appliance to the point where the exhaust gases exit the flue, must not exceed 30" (762 mm).

Standard venting may contain one (1) **\_DST5-45ELB** (45° elbow) if it is mounted directly against the back of the appliance. For standard venting options refer to Figures 11 and 12. Maximum allowable wall thickness is 23 1/2" when venting straight out the back of the appliance.

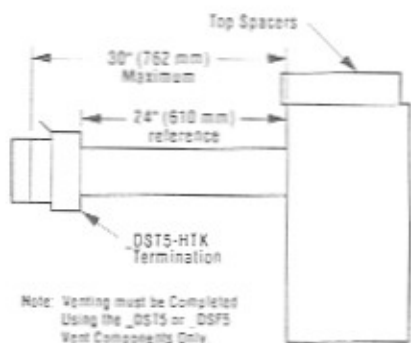

Figure 11



Figure 12

### EXTENDED VENTING

These Units may also be installed with extended venting configurations that allow for a variety of installation options. As in the standard venting configurations all extended vent runs may terminate through either a **\_DST5-HTK** or **\_DV-HTK** horizontal termination, however extended venting configurations may also terminate with a vertical termination.

Most extended venting configurations include two **\_DST5** 90° elbows. However some vent configurations may include up to three 90° elbows. **DO NOT USE THE **\_DSF5-24** FLEXIBLE VENT SECTION IN PLACE OF A 90° ELBOW.** Extended venting configurations may not start with a horizontal component in excess of eighteen (18") inches (457mm). The maximum vertical height of any extended vent configuration is 20' (6M). Maximum horizontal length for any extended venting configuration is 20' (6M). Intermediate vertical and horizontal dimensions can be calculated through a ratio not exceeding one (1) foot of horizontal length for every one (1) foot of vertical height. For extended venting options refer to Figures 13 and 14.

Contact the factory for approval before proceeding with any horizontally terminated vent system employing more than two (2) 90 degree elbows (4, 45 degree elbows) and any vertically terminated vent system employing more than one (1) 90 degree elbow (2, 45 degree elbows).

The minimum vertical height for extended vent configurations is sixteen (16") inches (406mm) measured centerline to centerline, refer to Figure 13. A **\_DVSP5** 90° starter elbow must be used at the top of the vertical vent run until the vertical height reaches a minimum of 52" (1321mm) measured centerline to centerline, refer to Figures 13 and 14. The vertical component of an extended venting configuration must be perpendicular (straight up), it may not be angled or offset.

### VENT INSTALLATION

Before proceeding determine the vent configuration to be used. Ensure vent clearance for standard venting configuration is 11" (279mm) at the top, 1" (25mm) at the sides and 1" (25 mm) at the bottom. If the appliance is to be installed in a corner as shown in Figure 12, do not allow any materials to occupy the space between the back of the appliance and the perpendicular walls.

Ensure vent clearance for extended venting configurations is 3" (76mm) at the top, 10" (254mm) at the top of horizontal components extended directly out from the back of the appliance, 1" (25mm) at the sides and 1" (25mm) at the bottom. Clearance to horizontal termination at the exterior wall remains as specified on page 3.

*Note: All venting height and length dimensions are measured from centerline to centerline and from the back surface of the appliance to the point where exhaust gas exits the flue within the termination.*

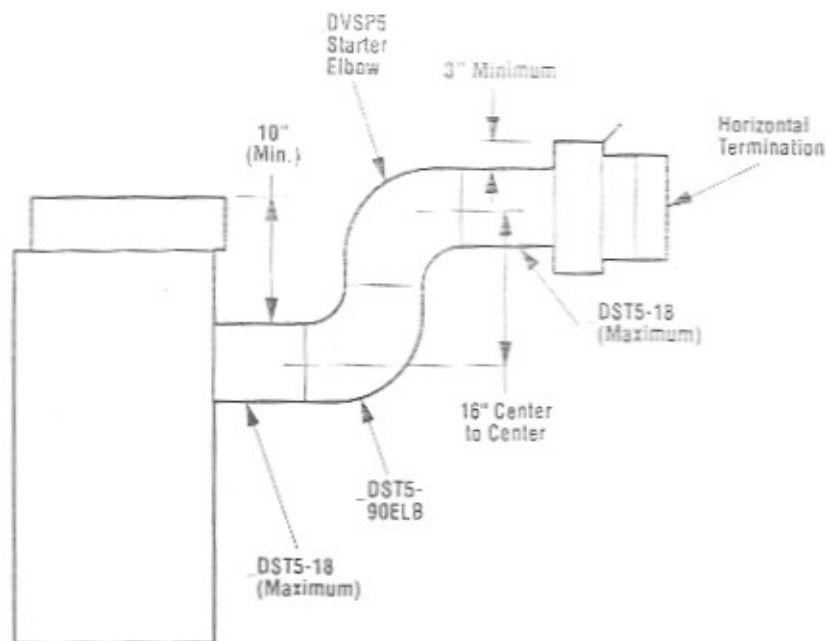
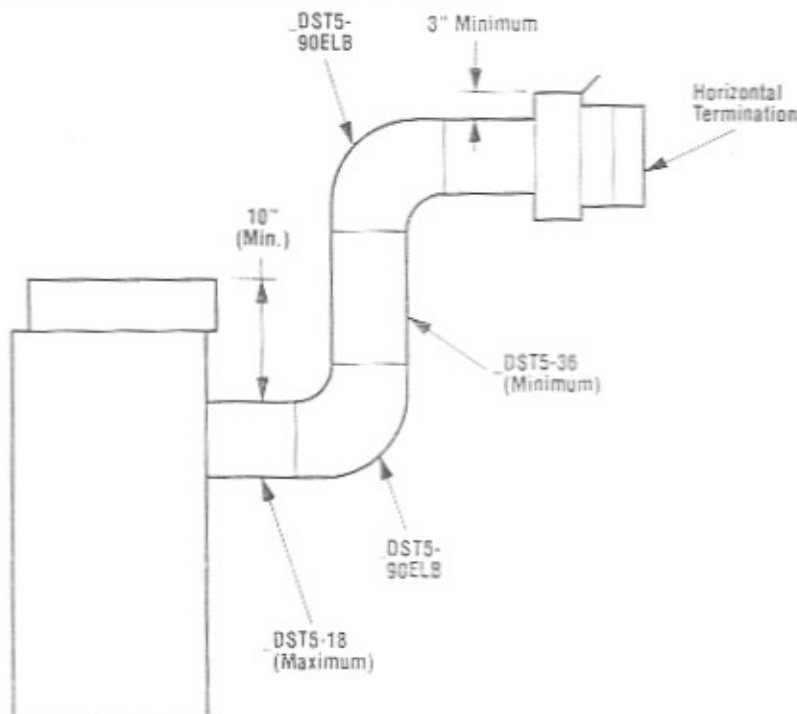

Figure 13

Note: The total horizontal and total vertical run components may continue at a 1 to 1 ratio. The maximum total combined length of either the horizontal or vertical run may not exceed 20 feet. Extended vent configurations may include up to three (3) 90 degree elbows. One (1) 90 degree elbow = two (2) 45 degree elbows.



Note: The first vertical leg must be 3 feet minimum before a DST5-90ELB may be used at the top of the run. These longer extended runs may terminate with a vertical termination, provided all the restrictions placed on the installation are met. Refer to extended venting options.

Figure 14

**WARNING: A 3/8" (10 MM) BEAD OF MILL-PAC BLACK (700°) HIGH TEMPERATURE SEALANT MUST BE APPLIED TO THE INNER APPLIANCE COLLAR BEFORE THE FIRST VENT COMPONENT IS ATTACHED (FIGURE 15) AND TO ALL SUBSEQUENT INNER VENT CONNECTIONS. FAILURE TO SEAL ALL OF THE INNER JOINTS WITH THE HIGH TEMPERATURE SEALANT MAY CAUSE THE APPLIANCE TO OPERATE IMPROPERLY.**

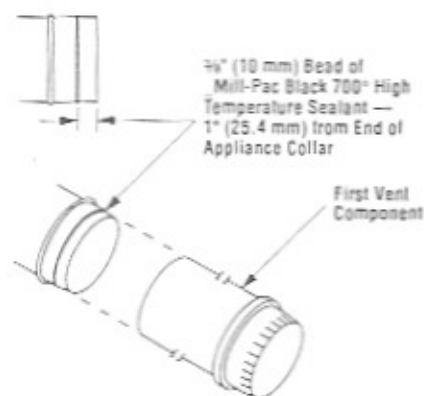

Figure 15

Note: Mill-Pac Black (700°) high temperature sealant must be applied to both ends of the inner mating components of the DST5 flexible vent component before completing any connections. Ensure seal is complete.

Vent components can be easily installed by simply fitting them together, inner flue components first. The DST5 and DSF5 flexible vent system components slide over the collars on the back of the appliance and bottom out on the beads. The DST5-45ELB connector components slide into the vent system components. Secure each end of the DST5 vent components with two (2) No. 8 x 1/2" sheet metal screws located 180° apart. Secure each end of the DSF5 flexible vent components with the hose clamps provided. Apply Mill-Pac Black (700°) high temperature sealant to all of the joints of the inner vent before fitting components together.

Attach the DST5-HTK connector tubes to the vent components and route the venting through the wall prior to installing the termination.

Note: The uncrimped end of the vent may be trimmed when necessary or the adjustable extension, Model DST5-EXT, may be used.



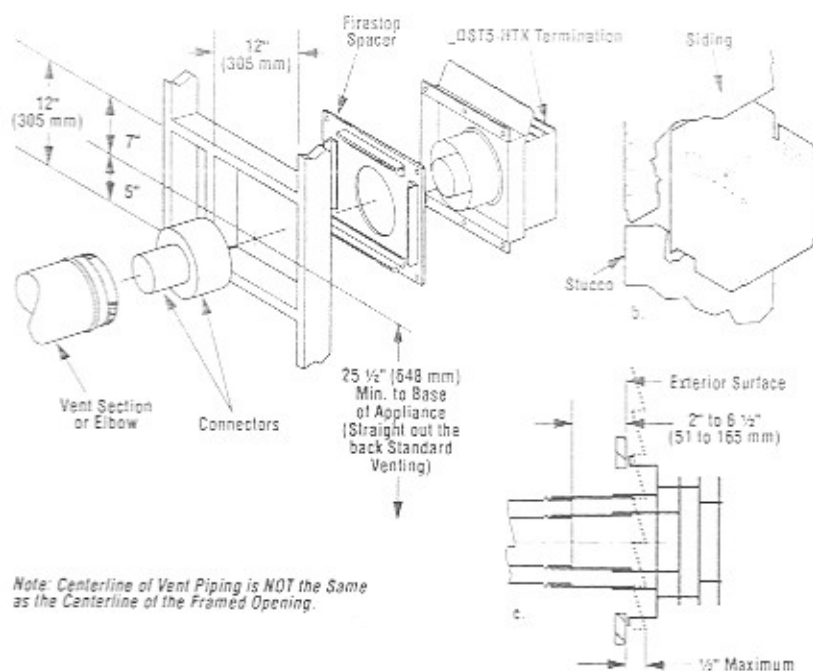

Note: Centerline of Vent Piping is NOT the Same as the Centerline of the Framed Opening.

Figure 16

To install the \_DST5-HTK apply a liberal bead of \_Mill-Pac Black (700°) high temperature sealant at the inner mounting flange for sealing purposes. Orient the housing with surface marked "top" upward. Visually align at the opening and carefully insert to engage over both inner and outer connector tubes. Slide inward until the housing bottoms at the finished exterior wall. **The horizontal termination must not be recessed into the exterior wall or siding in anyway.** Secure with 6d nails at holes in upper and lower flanges (Figure 16).

Note: Apply appropriate sealant to the outer edges of the \_DST5-HTK housing.

Install the vinyl wall shield onto the termination in accordance with the directions provided with the termination.

The \_DV-HTK termination installs in exactly the same way as the \_DST5-HTK termination. Orient the \_DV-HTK with the louvered wall shield upwards.

Roof Slope	Minimum Height from Roof to Lowest Discharge Opening
Flat to 6/12	1' 0"
Over 6/12 to 7/12	1' 3"
Over 7/12 to 8/12	1' 6"
Over 8/12 to 9/12	2' 0"
Over 9/12 to 10/12	2' 6"
Over 10/12 to 11/12	4' 0"
Over 11/12 to 12/12	5' 0"
Over 14/12 to 16/12	6' 0"
Over 18/12 to 20/12	7' 6"
Over 20/12 to 21/12	8' 0"

For SI units: 1 foot = 0.305 m

Table 1

## VERTICAL VENTING (Extended Venting Only)

Extended venting options include systems that vent vertically through the roof. A great deal of variation is possible when planning extended venting systems. Most vertically vented extended systems will incorporate only one 90 degree elbow, however some systems may employ more. Vertically vented systems may not exceed 20' (6.1M) in height. Two \_DST5-45ELB 45 degree elbows may be used in place of one \_DST5-90ELB 90 degree elbow.

**Gas Vent Rule** – Gas vent caps that are located 8' or more from a portion of a building which extends at an angle greater than 45° upward from the horizontal may terminate in accordance with Table 1 (Figure 17), provided that in no case shall any discharge opening on the cap be less than 2' (610 mm) horizontally from the roof surface.

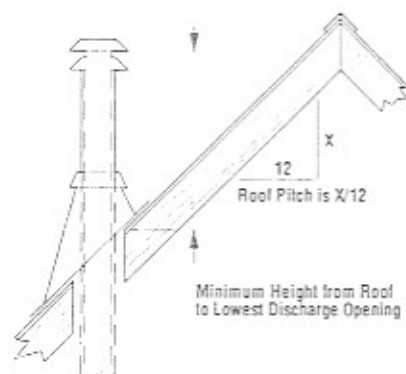

Figure 17

### Vertical Termination Systems (Roof)

The minimum vent height above the roof and/or adjacent walls is specified in ANSI Z223.1- (latest edition) (In Canada, the current CAN-1 B149 installation code) by major building codes. Always consult your local codes for specific requirements. A general guide to follow is the Gas Vent Rule (refer to Table 1).

The \_DSF5 flexible vent section can not be used in any application as part of a vertically terminating vent system.

### Vertical (Straight) Installation

Determine the number of straight sections required. 10 3/4" (273 mm), 16 3/4" (425 mm) and 34 3/4" (883 mm) net section lengths are available. Plan the vent lengths so that a joint does not occur at ceiling or roof joists.

*Note: The uncrimped end of the vent may be trimmed when necessary or the adjustable extension, Model \_DST5-EXT, may be used.*

**A.** Use a plumb line from the ceiling above the appliance to locate center of the vertical run. Cut and/or frame a 12" x 12" inside (305 mm x 305 mm) minimum opening about this center mark.

**B.** To add vent sections, start with the 5" (127 mm) inner section and slide it over the previously installed inner section; an overlap of 1 1/4" (32 mm) is required. The section will not bottom out on the bead. **Remember to seal inner sections using \_Mill-Pac Black (700°F) high temperature sealant on the mating surfaces before fitting together.** Secure with two (2) No. 8 x 1/2" sheet metal screws. Slide the 8" (203 mm) outer section over the previously installed outer section; a 1 1/4" (32 mm) overlap is required. This section will not bottom out on the bead. Make sure the crimped end of both inner and outer vent sections are the same height and that the centering spacer is properly seated. Secure with two (2) No. 8 x 1/2" sheet metal screws.

*Note: The uncrimped end of the vent may be trimmed when necessary or the adjustable extension, \_DST5-EXT, may be used.*

**C.** At transition from or to a horizontal run, the \_DST5-90ELB/ \_DST5-45ELB elbows install in the same manner as the straight vent sections. Apply Mill-Pac Black (700°F) high temperature sealant to the inner joints. Slip the inner elbow over the straight inner vent section. Secure with two (2) screws. Slide the outer elbow over the inner elbow, slip down over the outer vent section. Secure with two (2) screws.

**D.** Continue with the installation of the straight vent sections in horizontal run as described in Step B. Install support straps every 6' (2 m) along horizontal vent runs using conventional plumber's tape. It is very important that the horizontal run be maintained in a straight (no dips) and slightly elevated plane (1/4" rise/12" run). Use a carpenter's level to measure from a constant surface and adjust the support straps as necessary. It is important to maintain the required clearances to combustibles: 1" (25 mm) at all sides for all vertical runs; and 3" (76 mm) at the top, 1" (25 mm) at sides, and 1" (25 mm) at the bottom for all horizontal/ inclined runs.

**H.** Use a \_DST5-FSV firestop spacer at ceiling joists. If there is living space above the ceiling level, the firestop spacer must be installed on the bottom side of the ceiling. If attic space is above the ceiling, the firestop spacer must be installed on the top side of the joist. Route the vent sections through the framed opening and secure the firestop spacer with 8d nails at each corner. Remember to maintain 1" (25 mm) clearance to combustibles, framing members, and attic or ceiling insulation when running vertical chimney sections.

**F.** Identify location for vent at the roof. Cut and/or frame opening per Roof Framing Chart and Figure 18.

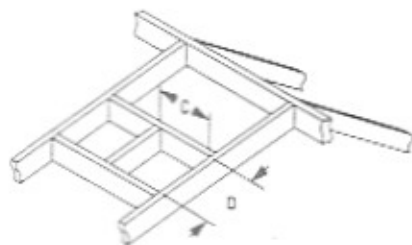

Figure 18

Framing Dimensions for Roof

Pitch	C	D
0/12	10" (254 mm)	10" (254 mm)
6/12	10" (254 mm)	12" (305 mm)
12/12	10" (254 mm)	17 3/4" (305 mm)

NOTE: DIAGRAMS & ILLUSTRATIONS NOT TO SCALE

**G.** Extend the vent sections through the roof structure. Install the roof flashing over the vent section and position such that the vent column rises vertically (use carpenter's level) (Figure 19). Nail along perimeter to secure flashing or adjust roofing to overlap the flashing edges at top and sides only and trim where necessary. Seal the top and both sides of the flashing with waterproof caulking.

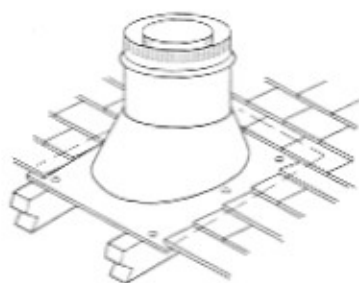

Figure 19

**H.** Install the storm collar, supplied with the flashing, over the vent/flashing joint. Wrap the storm collar around the vent noting which locking groove closely aligns with the tab (Figure 20). Pencil mark excess material, unwrap and trim excess with shears. Reposition collar, insert tab through both slots, pull tab so that collar is tight around vent. Slide collar down until it meets top of the flashing. Bend tab back over slot. Apply noncombustible caulking or mastic around circumference of the joint and the tab slot area to provide a water tight seal.

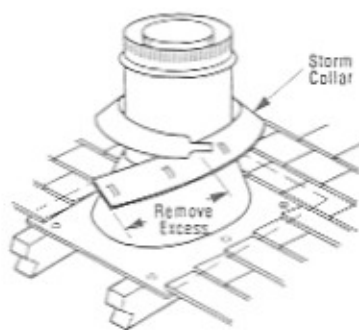

Figure 20

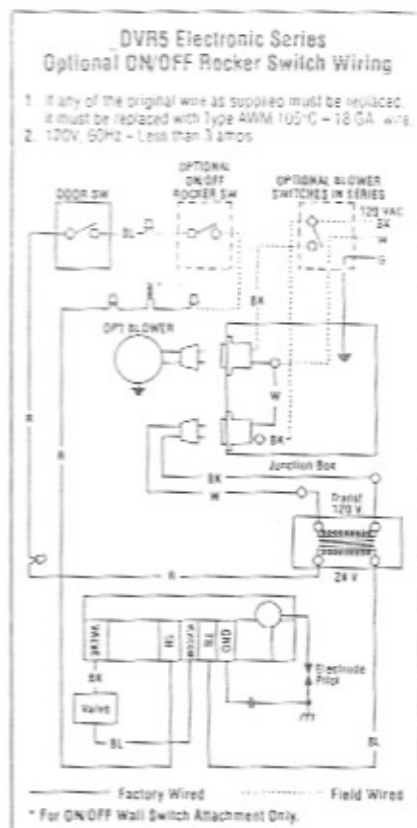

Figure 25

**Step 8. Installing the Optional Forced Air Blower Kit Wiring** – An electrical outlet box is provided for the installation of the \_FAB-1100 or \_FAB-1600 forced air blower kit (optional). Electrical power must be provided to this box to operate the blower.

Route a 3-wire, 120Vac power line with control switch to the lower left front corner of the appliance. Supply wires are to be connected to the outlet as shown in Figure 26, ensuring that the polarity (as determined by the colors of the wires) is exactly as shown. The black and red wire loop must be left intact, with the mating connectors connected.

**IMPORTANT:** Ground lead must be connected to the green screw located on the junction box cover plate. Failure to do so will prevent the appliance from operating. The appliance must be electrically grounded in accordance with local codes or, in the absence of local codes, the National Electrical Code, ANSI/NFPA 70-(latest edition). (In Canada, the current CSA C22-1 Canadian Electrical Code.)

The standard optional forced air blower kit or blower kit with thermal snap switch, may be mounted at initial appliance installation or at any time thereafter. Follow the instructions provided with the blower kit.

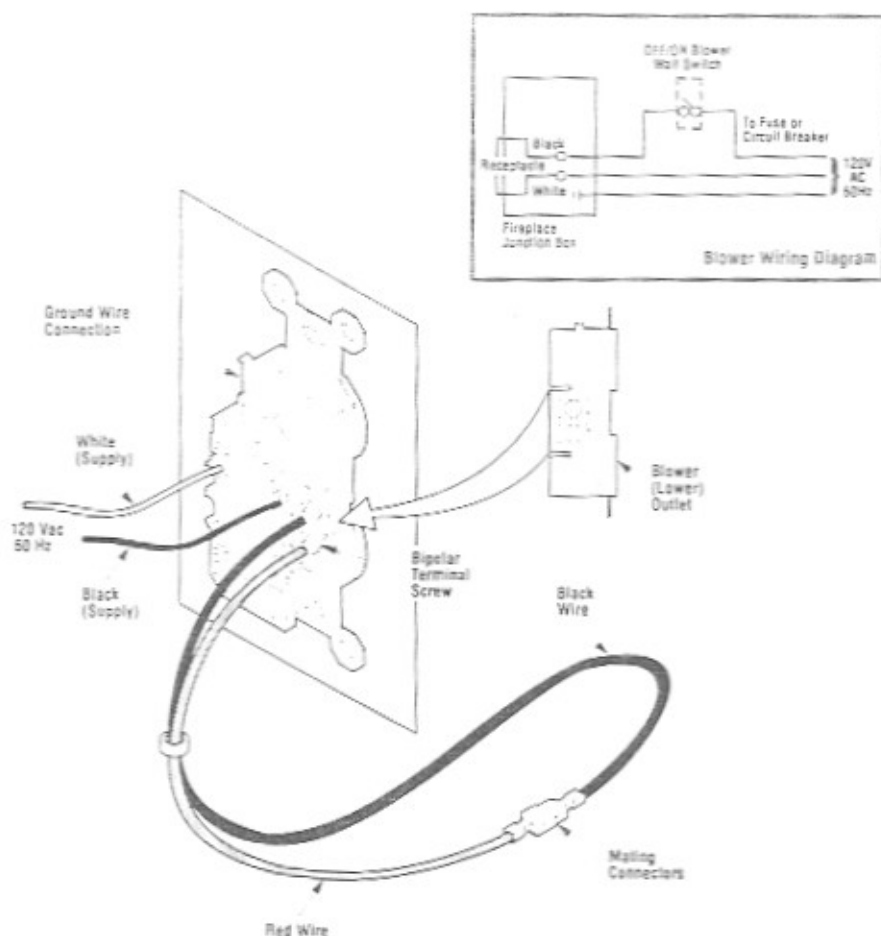

Figure 26

*Note:* Supply wires may be alternatively connected to the outlet using the screw terminals, however the black supply wire must be ganged wired to the same terminal that the pre-wired black wire is attached to and the white supply wire must be connected to the opposite side of the outlet.

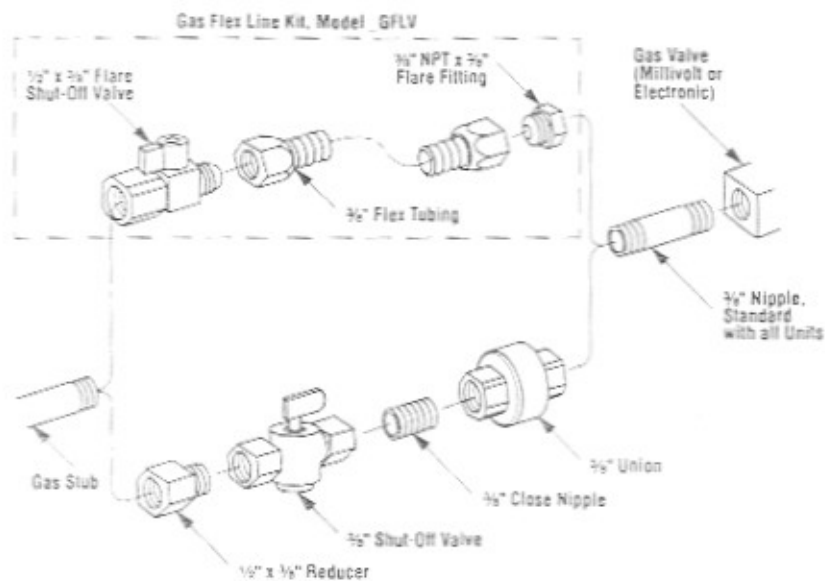

Figure 27

1. The final step involves installation of the \_DST5-VTK termination kit. Extend the vent sections to height defined by the applicable gas appliance code, or as indicated by the Ten Foot Rule.

Apply \_Mil-Pac Black (700°F) high temperature sealant and slide the inner termination section down over the last inner vent section. Ensure overlap is a minimum of 1 1/4" (32 mm) (Figure 21).

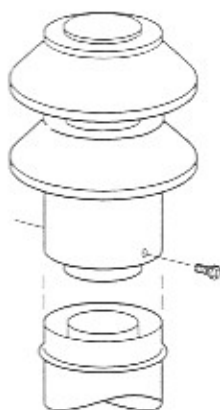

Figure 21

Slide the outer termination down over the last outer vent section. The two (2) holes in the outer sleeve are used to secure the termination. Transfer drill 3/8" (3 mm) diameter hole through outer wall of top vent section. Secure with two (2) No. 8 x 1/2" sheet metal screws.

If the vent system extends more than 5' (1.5 m) above the roof flashing, stabilizers may be necessary. Additional screws may be used at section joints for added stability. Guy wires may be attached to the joint for additional support on multiple joint configurations.

If the vent system extends more than 10' vertically, the \_DST5-VTK must be fitted with \_DV-ARK air restrictors that will reduce the volume of combustion air entering the appliance. Refer to Step 13 for the air restrictor kit installation and adjustment details.

**Step 6. Installing the Optional Remote Wall Switch** – The standard \_DVR6 millivolt system comes from the factory wired as shown in Figure 22. Select a convenient location for the remote wall switch and connect the wiring to the appliance (Figure 23).

**CAUTION: DO NOT CONNECT THE OPTIONAL REMOTE SWITCH TO A 120V POWER SUPPLY.**

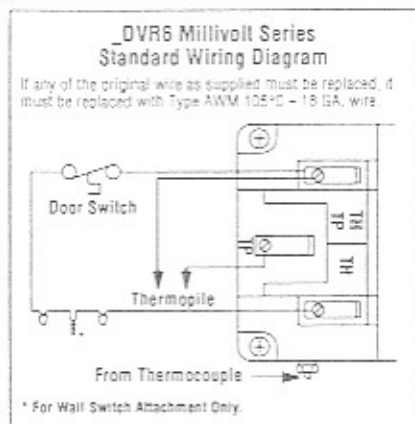

Figure 22

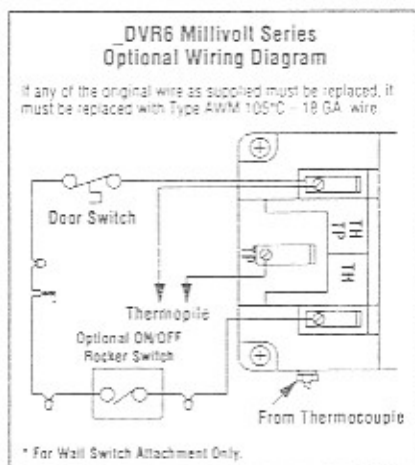

Figure 23

*Note: The optional rocker switch is mounted to the appliance and wired in the same way as the remote wall switch.*

**Step 7. Field Wiring Electronic Appliances** – Regardless of whether an optional forced air blower kit is to be installed now or sometime in the future, the appliance must be connected to the main power supply. To install, route a 3-wire 120V 60Hz power supply to the appliance junction box (located in the lower right side of the appliance) and ground. Also, locate and install the low voltage (24V) wall switch in the desired location, connect the low voltage wire to this switch and/or install thermal snap switch in series. Refer to the installation instructions provided with the forced air kit. (Figure 24).

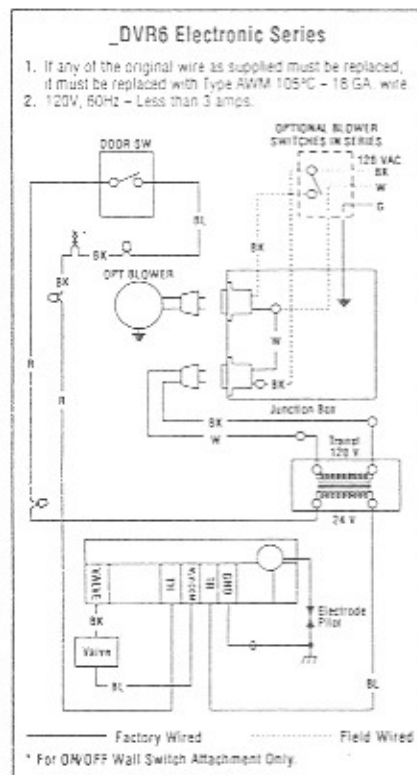

Figure 24

**CAUTION: DO NOT CONNECT THE OPTIONAL REMOTE SWITCH TO A 120V POWER SUPPLY.**

*Note: A thermostat control must be installed in Canadian bedroom installations of electronic ignition units.*

*Note: The optional rocker switch is mounted to the appliance and wired in the same way as the remote wall switch (Figure 25).*

**Step 9. Connecting Gas Line** – Make gas line connections. All codes require a shut-off valve mounted in the supply line. *Figure 27* illustrates two methods for connecting the gas supply. The flex-line method is acceptable in the U.S.; however, Canadian requirements vary depending on locality. Installation must be in compliance with local codes.

The gas control valve is located in the lower control compartment. To access the valve open the lower control compartment door (*Figure 28*). The millivolt control valve has a  $\frac{3}{8}$ " NPT thread inlet port. The electronic control valve has a  $\frac{1}{2}$ " NPT thread inlet port and is fitted with a  $\frac{1}{2}$ " x  $\frac{3}{8}$ " NPT fitting. Both the millivolt and electronic models are fitted with a 3" (76 mm) long nipple,  $\frac{3}{8}$ " NPT. Plan the connections accordingly.

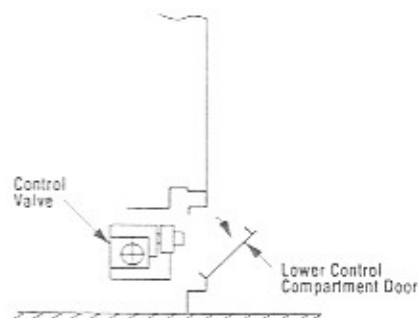

**Figure 28**

Secure all joints tightly using appropriate tools and sealing compounds (ensure propane resistant compounds are used in propane applications). Turn on gas supply and test for gas leaks using a soapy water solution. **Never use an open flame to check for leaks.**

- A. Mix a 50% dish soap, 50% water solution.
- B. Light the appliance (see safety and lighting instructions on pages 24 through 27).
- C. Brush all joints and connections with the soapy water solution to check for leaks. If bubbles are formed, or gas odor is detected, turn the gas control knob to the "OFF" position. Either tighten or refasten the leaking connection and retest as described above.
- D. When the gas lines are tested and leak free, observe the individual tongues of flame on the burner. Make sure all ports are open and producing flame evenly across the burner. If any ports are blocked, or partially blocked, clear out the ports.

#### High Elevation Derating

**WARNING: THE DERATING KIT IS TO BE INSTALLED BY AN AUTHORIZED DISTRIBUTOR OR OTHER FACTORY CERTIFIED SERVICE TECHNICIAN IN ACCORDANCE WITH THE MANUFACTURER'S INSTRUCTIONS AND ALL CODES AND REQUIREMENTS OF THE AUTHORITY HAVING JURISDICTION. FAILURE TO FOLLOW THESE INSTRUCTIONS COULD RESULT IN SERIOUS INJURY OR PROPERTY DAMAGE. THE QUALIFIED AGENCY PERFORMING THIS WORK ASSUMES RESPONSIBILITY FOR THIS DERATING.**

#### In Canada

THE DERATING SHALL BE CARRIED OUT IN ACCORDANCE WITH THE REQUIREMENTS OF THE PROVINCIAL AUTHORITIES HAVING JURISDICTION AND IN ACCORDANCE WITH THE REQUIREMENTS OF THE CAN1-B149.1 AND .2 INSTALLATION CODE.

This unit has been tested for installation at high altitudes in accordance with Canadian test standard CAN/CGA-2.17.

Higher altitudes affect the atmospheric pressure and heat value of gaseous fuels. When installing this unit at high altitudes, the rated input will be lower than that at sea level. The lowered oxygen content in the air and lowered gas viscosity require installation of a different orifice to achieve efficient, clean combustion at the burner assembly. Refer to the following chart and/or the rating plate on the appliance for proper orifice size.

To derate this unit, order and install the appropriate high altitude orifice kit per the chart below. Remove the two (2) screws found at the base of the burner tray and remove the burner tray with tube. Use care to prevent damage to the air shutter adjustment rod. Remove the orifice (*Figure 29*) and replace with the appropriate one from the kit. Refer to the chart below. Be sure to attach the conversion sticker provided with the kit to the rating plate on the appliance.

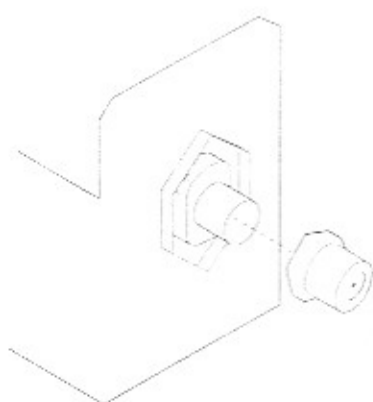

**Figure 29**

Gas Type	Orifice Size	High Alt Orf. Kit	Elevation
Natural	#36 (.106)	—	0 - 2000' (0 - 610 m)
	#38 (.101)	SFC P/N 064104	2000 - 4500' (610 - 1370 m)
Propane	#52 (.063)	—	0 - 2000' (0 - 610 m)
	(.057)	SFC P/N 064087	2000 - 4500' (610 - 1370 m)

U.S. per ANSI Z223.1-1992  
Canada per CAN/CGA 2.17-M91.

**Step 10. Installing Logs and Rockwool** – The logs are packaged within the firebox. The bag of Rockwool is in the lower control compartment. Remove the Rockwool from its packaging. Place the Rockwool over the exposed screen at the base of the front bottom log hiding the front burner element and screen from view. When properly positioned the Rockwool will unevenly cover approximately 85% of the screen area with no appreciable gaps.

Carefully position and center the fiber logs onto the burner with the longer, scalloped and charred log in front and the shorter log in the back. Position the front log with the cutout on its back fitted around the burner tube. Position the rear log matching the cutout on its bottom with the position of the pilot. There should be a  $\frac{1}{8}$ " (13 mm) gap between the rear log and the back wall of the firebox unless either the optional porcelain panel kit or refractory liner kit is installed. Ensure that the burner bracket mounting tabs are located within the holes of these logs.

Place the three (3) smaller fiber logs (twigs) across the two (2) lower logs in the manner illustrated. Position the left twig first on two pins, one in the front log and one in the rear log. Position the center twig over two (2) pins, one in the rear log and one in the front log. Then position the right twig on top of the end of the center twig and on to the remaining pins in the rear and front log (Figure 30). When operating, flames should project through the opening in the left twig. The flames should not impinge on the logs.



Figure 30

#### Appliance Operation

**Step 11. Checking the System** – With gas line installed run initial system checkout before closing up the front of the unit. Follow the pilot lighting instructions on page 18 for millivolt appliances. Refer to page 26 for electronic appliance lighting instructions.

*Note: Instructions are also found on the pull out panel located on the bottom surface of the appliance.*

*Note: The safety switch must be held closed for burner operation when testing.*

When first lighting the appliance, it will take a few minutes for the line to purge itself of air. Once purging is complete, the pilot and burner will light and operate as indicated in the instruction manual. Subsequent lightings of the appliance will not require such purging. Inspect the pilot flame (remove logs, if necessary, handling carefully)

#### Millivolt Appliance Checkout

The pilot flame should be steady, not lifting or floating. Flame should be blue in color with traces of orange at the outer edge.

The top  $\frac{3}{8}$ " (10 mm) at the pilot generator (thermopile) and the top  $\frac{1}{8}$ " min (tip) of the quick drop out thermocouple should be engulfed in the pilot flame. The flame should project 1" (25 mm) beyond the hood at all three ports (Figure 31).

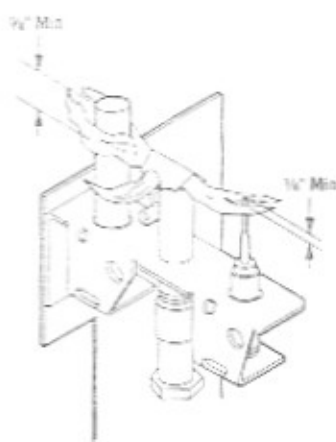

Figure 31

Replace logs if removed for pilot inspection.

To light the burner; turn "ON" the remote wall switch, manually depress and hold the door switch (Figure 32) and rotate the gas valve control knob counterclockwise to the "ON" position ("ON" will be at the bottom side of the valve).

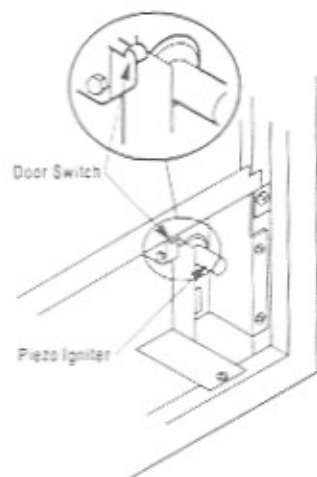

Figure 32

#### Electronic Appliance Checkout

To light the burner, turn "ON" the remote wall switch, manually depress and hold the door switch (Figure 32) and rotate the gas valve control lever up to the "ON" position (the lever will be in the "ON" position when the lever is sticking straight out).

If the burner fails to light, check that the gap between the igniter electrode and the burner tube is  $\frac{3}{16}$ "  $\pm$   $\frac{1}{32}$ ". If the gap is incorrect, bend the top of the electrode to within this limit.

**Step 12. Installing the Glass Door Frame** – Retrieve the glass door frame. Visually inspect the gasket on the backside of the panel. Gasket surface must be clean, free of irregularities and seated firmly.

Position the door frame in front of the firebox opening, with the joint in the gasket down (Figure 33). Locate the three (3) tabs at the bottom edge of the door frame into the three (3) brackets at the base of the fireplace front opening. Lean the door frame back towards the fireplace ensuring that the gasket seats evenly as the door frame draws shut. Install the three (3)  $\frac{1}{4}$ "-20 x 1" Phillips pan head screws removed previously and tighten to secure. Ensure that the tab on the bottom of the door frame engages the door switch.

Make sure the screws are tightened equally to avoid torquing the door.

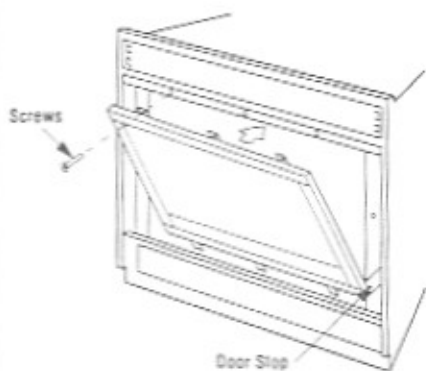

Figure 33

**WARNING: HANDLE THIS GLASS WITH EXTREME CARE! TEMPERED GLASS IS SUSCEPTIBLE TO DAMAGE — DO NOT SCRATCH WHILE HANDLING OR WHILE RE-INSTALLING THE GLASS DOOR FRAME.**

**Step 13. Burner Adjustments** – The following paragraphs address burner adjustment concerns and procedures.

## Flame Appearance and Sooting

Proper flame appearance is a matter of taste. Generally most people prefer the warm glow of a yellow to orange flame. Appliances operated with air shutter openings that are too large will exhibit flames that are blue and transparent.

These weak, blue and transparent flames are termed anemic. If the air shutter opening is too small sooting may develop. Sooting is indicated by black puffs developing at the tips of very long orange flames. Sooting results in black deposits forming on the logs, appliance inside surfaces and on exterior surfaces adjacent to the vent termination. Sooting is caused by incomplete combustion in the flames and a lack of combustion air entering the air shutter opening.

To achieve a warm yellow to orange flame with an orange body that does not soot, the shutter opening must be adjusted between these two extremes and appliances installed with long vertical (extended venting) runs must be fitted with air restrictor kit, model DV-ARK.

The primary cause of anemic flames in these systems is excessive secondary combustion air. The symptom of this (anemic flames) occurs when vertical vent runs are in excess of ten feet. To prevent this from occurring it is necessary to install the air restriction kit, Model DV-ARK, on the DST5-VTK vertical termination. To install the air restriction rings refer to the installation instructions provided in the kit. Secure the rings in place with the screws provided.

**Note:** Excessive primary and secondary combustion air are the main cause of anemic flames. The air restrictor kit can reduce the availability of both of these. Install the air restrictor kit before making any adjustments to the air shutter opening. If, at initial start up, the appliance exhibits signs of sooting do not install the air restrictor kit, regardless of any height requirements.

No smoke or soot should be present. Reposition the logs as shown in Figure 34 if the flames impinge on any of them.



Figure 34

If sooting conditions exist, the air shutter opening on the main burner tube can be adjusted. Normally, the more offsets in the vent system, the greater the need for the air shutter to be opened further.

**WARNING: AIR SHUTTER ADJUSTMENT SHOULD ONLY BE PERFORMED BY A QUALIFIED PROFESSIONAL SERVICE TECHNICIAN.**

**Note:** If refractories are installed, remove them prior to the adjustment procedure to prevent permanent damage from soot build-up. Ensure that the door is closed and sealed during adjustment.

### Adjustment

**CAUTION: THE ADJUSTMENT ROD AND NEARBY APPLIANCE SURFACES ARE HOT. EXERCISE CAUTION TO AVOID INJURY WHILE ADJUSTING FLAME APPEARANCE.**

To adjust the flame, move the adjustment rod up or down (located in the lower control area). Position the air shutter to the nominal setting (Figure 35). Allow the burner to operate for at least 30 minutes. Observe the flame continuously. If it appears weak or sooty as previously described, adjust the air shutter by pushing or pulling on the adjustment rod until the flame appearance is as desired. The adjustment rod and associated adjustable air shutter is patented technology. Flame adjustments can be made quickly and accurately to taste without the need of disassembling the appliance and waiting for 30 minutes after each adjustment.

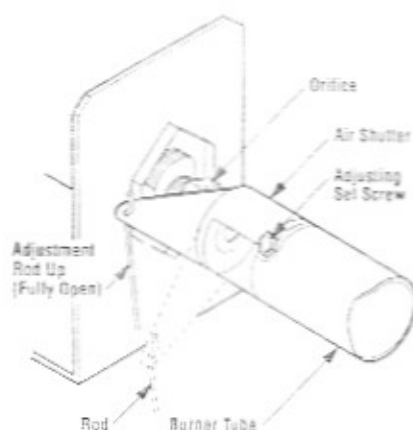

Nominal Air Shutter Settings  
Natural Gas -  $\frac{3}{4}$ " Open  
Propane Gas -  $\frac{1}{2}$ " Open

Figure 35

**Note:** If the flame still appears anemic with the air shutter closed all the way (usually a result of lengthy vertical venting runs), turn off the appliance, turn off the gas supply, wait for the parts to cool and access the air shutter. The shutter is prevented from actually closing by a tab that is bent over into the opening. Remove this obstruction by bending back. Reassemble and restart the appliance and after 30 minutes reobserve the flame. Adjust the air shutter as described.

When satisfied that the appliance operates properly, proceed to finish the installation. Leave the control knob in "ON" position and turn the remote switch "OFF." Close the control compartment door.

## FINISHING REQUIREMENTS

### Wall Details

Complete finished interior wall. To install the appliance facing flush with the finished wall, position framework to accommodate the thickness of the finished wall (Figures 36 and 37).

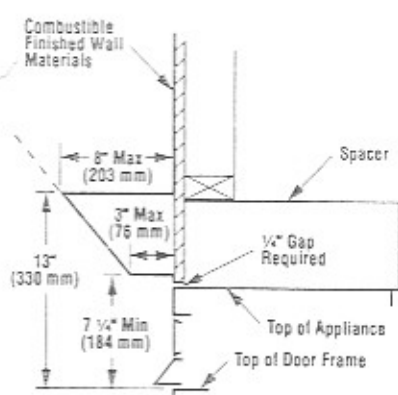

Model DVRS-R (Clean Face)

Figure 36

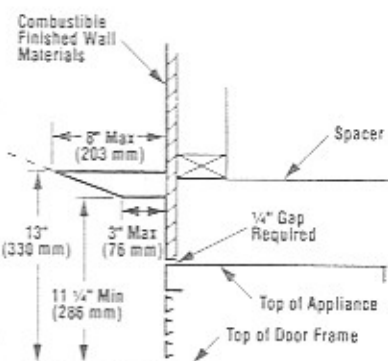

Model DVRS-C (Louver Trim)

Figure 37

A hearth extension is not required with this appliance. If a hearth extension is used, do not block the lower control compartment door. Any hearth extensions used is for appearance only and does not have to conform to standard hearth extension installation requirements.

**Note:** Combustible wall finish materials and/or surround materials must not be allowed to encroach the area defined by the appliance front face (black sheet metal). Never allow combustible materials to be positioned in front of or overlapping the appliance front face.

A combustibleside mantel shelf projecting a maximum of 8" (203 mm) from the wall may be installed a minimum distance of 13" (330 mm) from the top of the door frame (Figure 38).

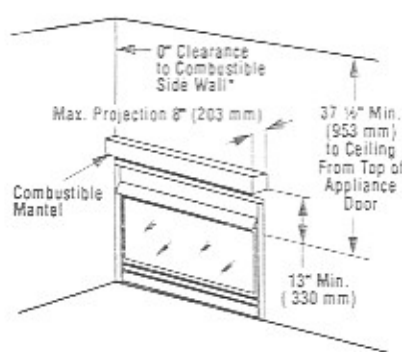

Figure 38

### COLD CLIMATE INSULATION

If you live in a cold climate, seal all cracks around your appliance with noncombustible material and wherever cold air could enter the room. It is especially important to insulate outside chase cavity between studs and under floor on which appliance rests, if floor is above ground level.

### DIRECT VENT SERIES OPTIONS

An incomparable package of options are available for use with the Direct Vent Series. These options can both customize the operation of these unique appliances and enhance their beauty and charming appeal. All options are available in kit form, are easy to install and are packaged complete with all required parts and instructions. Some of the option kits need to be fitted prior to completing the installation of the appliance. The following paragraphs detail the kit options available for use with the appliances covered in this manual.

These outstanding optional items can be added individually or in sets of two or more to customize your direct vent appliance to fit your homes unique needs. Kit part numbers are provided on pages 21, 22 and 23 along with descriptive illustrations.

### Split Logs

The decorative split log set is ideal for enhancing the rustic look of your fireplace. The split log set is designed to provide the look and feel of split log timber. This set is designed to be placed in the firebox exactly as the standard logs do. This kit can be retrofitted into all previously installed appliances.

*\*Note: For Canadian installations, 6" (152 mm) clearance to combustibleside wall required*

### Forced Air Kits

The FAB-1100 single speed or FAB-1600 assembly with variable speed wall switch provides a forced air circulation feature for your appliance. These kits mount directly into the lower intake chamber with an electrical connection made at the receptacle provided. The appliance must have an independent 120Vac power line incorporated at the time of installation. Refer to Step 6 of the installation instructions supplied with the forced air kit (Figures 39 and 40).

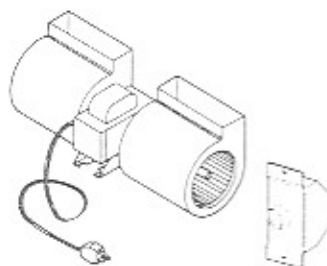

Figure 39

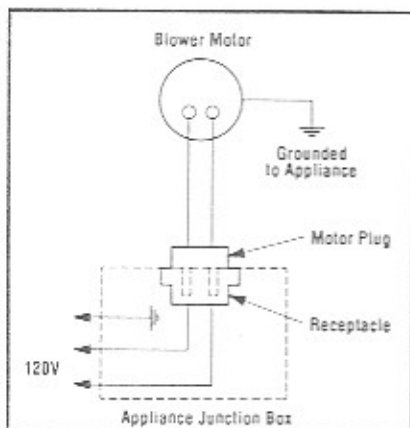

Figure 40

### Remote Control Kit

The Model\_RCK adds the convenience of remote control for your appliance. The kit includes a wireless, hand held transmitter and a receiver that replaces the wall switch. This special receiver permits either manual or remote control modes. Both receiver and transmitter operate on standard 9 volt batteries (not included). Refer to the\_RCK installation instruction for specific details.



### Wall Switch Kit

An optional wall switch kit can be installed along with all \_DVR6 Series appliances. The kit consists of a standard UL wall switch with cover plate. This kit provides for remote (wall) operation of the appliance. Replace the wall switch and cover plate of this kit with the components of the \_RCK and you can have true remote control of your direct vent appliance, turning it on and off from your favorite easy chair. The wall switch kit should be installed along with the appliance. Refer to *Figures 23 and 25* and Steps 6 and 7 for detailed installation instructions.

### Optional on Unit Rocker Switch

An optional rocker switch kit can be installed directly on all \_DVR6 Series appliances to provide for On and Off operation in lieu of a wall switch. This kit is designed to install in the lower control compartment out of view and is perfect for use in high volume areas such as lobbies and model homes where limited access to the appliance On/Off switch is desirable. This kit can be retrofitted to previously installed appliances and may be temporarily installed in place of other switch circuitry.

### Decorative Volcanic Stone

The decorative volcanic stone, Model \_DVS, which will not burn glows and looks like burning coals. By placing the volcanic stone along the burner screen below the front log, an extremely realistic firebed can be established.

### Square Trim Kit

A square trim kit is available for the Direct Vent Series. This kit is easy to install and does not require hardware to attach it as designed, directly to the standard door frame. The four piece square trim kit can be installed without the bottom or bottom and side pieces to customize the look of our appliance. This kit can be retrofitted to previously installed appliances.

### Brass Filigree Trim Kit

The decorative brass filigree trim kit is for use with all \_DVR6-C direct vent louvered-face appliances. The decorative filigree kit is designed to replace the standard black louvers that are provided with the appliance and may be used in conjunction with components of the brass louver kit. The decorative filigree trim simply snaps into place to provide your appliance with a warm traditional look. This kit can be retrofitted to previously installed appliances.

### Refractory Liner Kit

One of the most beautiful enhancements you can make to the \_DVR6 Series is the addition of refractory liners. The refractory liner kit includes ceramic fiber panels for the rear and side walls of the firebox. The ceramic fiber panels have brick-like features in relief. To install the five panels, simply place them in position against the firebox walls. This kit can be retrofitted into previously installed appliances.

### Porcelain Panel Kit

An alternative to the standard and refractory liner looks of the \_DVR6 Series appliances is a porcelain panel for the back wall of the firebox. The porcelain panel reflects the image of the flames, greatly enhancing the warm appeal of the \_DVR6 fire. The porcelain panel mounts directly against the firebox back wall with the hardware provided with the kit. This kit can be retrofitted to previously installed appliances.

### Brass Hood

Attractive brass hoods are available in two styles to be used on both the clean-face or louvered-face \_DVR6 appliances. These hoods are designed to be fitted to the face of the appliance directly above the door. In addition to providing an aesthetically pleasing appearance to your appliance installation, the hood reduces heat effects to decorative mantles and finish materials located directly above the fireplace opening. The \_DVR6-R hood kit includes the necessary attaching hardware. The \_DVR6-C hood kit snaps into place in the position of the uppermost top louver. These kits can be retrofitted to previously installed appliances.

### Brass Louvers

Decorative brass louvers are available for use with all \_DVR6-C direct vent louvered-face appliances. These louvers are designed to replace the standard black louvers that are provided with the appliance. The brass louver kit includes six (6) brass louvers that simply snap into place. They provide a touch of elegance to any \_DVR6-C appliance. This kit can be retrofitted to previously installed appliances.

### Decorative Log Rack

The decorative log rack provides the look of a wrought iron log grate. The log rack is easy to install. Simply place the log rack in front of the gas logs. This kit can be retrofitted to previously installed appliances.

### Brass Square Surround Kit

A decorative brass square surround kit is available for use with these appliances. The \_BSK-6 is designed to attach directly to the front face of the appliance at its extreme edges. The \_BSK-6 provides a picture frame finish for the appliance 2 1/2" wide. The brass square surround kit can be retrofitted onto previously installed appliances.

### Screen Panel Kit

An optional screen panel can be installed on the \_DVR6 door. This screen panel is easy to install using the provided hardware. The screen panel can be installed with both ceramic and tempered glass in the door. This kit can be retrofitted to previously installed \_DVR6 appliances. The screen panel kit can not be used in conjunction with either of the decorative arch kits.

### Decorative Arch Kits

Two arch kits are available for the \_DVR6 Series. A one-piece complete door arch kit and a four-piece arch frame kit. Both kits are easy to install and do not require hardware to attach them to the standard door frame. The four-piece arch frame kit can be installed without the bottom or bottom and side pieces to customize the look of your appliance. These kits can be retrofitted to previously installed \_DVR6 Series appliances. The decorative arch kits can not be used in conjunction with the screen panel kit.

### Ceramic Glass Kit

The standard tempered glass of the direct vent door assembly can be replaced with ceramic glass if desired. The ceramic glass kit includes a ceramic glass panel with a factory mounted gasket. The ceramic glass panel is installed within the door frame in place of the tempered glass. This kit can be retrofitted to previously installed \_DVR6 Series appliances.

### Gas Flex Line with Valve

A gas flex line kit is available to aid in attaching the direct vent appliance to the gas supply. This kit can only be used where local codes permit. The kit includes a 1/2" NPT to 3/8" (10 mm) flare in line shut-off valve, a 12" (305 mm) flex line 3/8" (10 mm) female flare through and a 3/8" (10 mm) flare to 1/2" NPT fitting. The components of this kit are rated for both natural and propane gas. This kit is designed to be used as an aid in installing the appliance.

## Gas Conversion Kits

**WARNING: THE CONVERSION KIT IS TO BE INSTALLED BY AN AUTHORIZED DISTRIBUTOR OR OTHER FACTORY CERTIFIED SERVICE TECHNICIAN IN ACCORDANCE WITH THE MANUFACTURER'S INSTRUCTIONS AND ALL CODES AND REQUIREMENTS OF THE AUTHORITY HAVING JURISDICTION. FAILURE TO FOLLOW THESE INSTRUCTIONS COULD RESULT IN SERIOUS INJURY OR PROPERTY DAMAGE. THE QUALIFIED AGENCY PERFORMING THIS WORK ASSUMES RESPONSIBILITY FOR THIS CONVERSION.**

### In Canada

THE CONVERSION SHALL BE CARRIED OUT IN ACCORDANCE WITH THE REQUIREMENTS OF THE PROVINCIAL AUTHORITIES HAVING JURISDICTION AND IN ACCORDANCE WITH THE REQUIREMENTS OF THE CAN1-B149.1 AND .2 INSTALLATION CODE.

Gas conversion kits are available to adapt your direct vent appliance from the use of one type to the use of another. These kits contain all the necessary components needed to complete the task including labeling that must be affixed to ensure safe operation. Kit part numbers are listed below and the following steps detail the conversion procedure.

#### Millivolt Conversion Kits

SFC P/N 064083 — Natural to Propane  
SFC P/N 064115 — Propane to Natural

#### Electronic Conversion Kits

SFC P/N 064085 — Natural to Propane  
SFC P/N 064117 — Propane to Natural

**Step 1.** Turn off the gas supply to the appliance. Remove the front glass door frame from the appliance. Open the lower control compartment door.

**Step 2.** Carefully remove the three (3) twigs on top. Then remove the two (2) main logs. Exercise care as not to break the logs.

**Step 3.** Remove the two (2) screws located at the rear of the burner tray. Remove the burner tray with the burner. Use care to prevent damage to the air shutter adjustment rod. Lift the rear of the burner tray up slightly and to the right to disengage the burner tube from the manifold and orifice.

**Step 4. Millivolt Appliances** — Remove and replace the regulator assembly located on the front of the gas valve (Figure 41). Ensure that the gasket is seated properly and is not kinked.

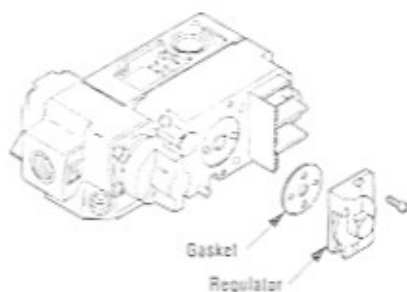

Figure 41

**Step 5. Electronic Appliances** — Remove ten (10) screws and remove the complete spud assembly.

**Step 6. Electronic Appliances** — Mark the wires to the gas valve. Then remove and replace the gas valve (Figure 42).

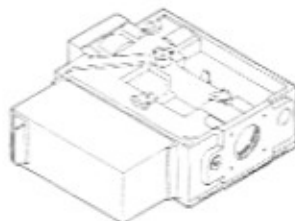

Figure 42

**Step 7.** Unscrew the orifice from the manifold and replace it with the one provided with the kit, #36 (106) for natural gas units and #52 (063) for propane (Figure 29).

**Step 8. Millivolt Appliances** — Replace the pilot orifice with the one provided with the kit (Figure 43).



Figure 43

**Step 9.** Reassemble all removed components by reversing the procedures outlined in the preceding steps. Inspect spud gasket for damage; replace if necessary. Use pipe joint compound or Teflon tape on all fittings before installing (ensure propane resistant compounds are used in propane applications).

**Step 10.** Attach conversion kit label to the rating plate on the appliance; Label F for units converted to natural gas or Label L for units converted to propane (Figure 44).



Figure 44

**Step 11.** Turn on gas supply and test for gas leaks as described in the gas line connection instructions, Step 9 on page 9.

**WARNING: CHILDREN AND ADULTS SHOULD BE ALERTED TO THE HAZARDS OF HIGH SURFACE TEMPERATURES. USE CAUTION AROUND THE APPLIANCE TO AVOID BURNS OR CLOTHING IGNITION. YOUNG CHILDREN SHOULD BE SUPERVISED WHEN THEY ARE IN THE SAME ROOM AS THE APPLIANCE.**

**WARNING: THE LOWER CONTROL COMPARTMENT AREA AND LOWER CONTROL COMPARTMENT ACCESS DOOR ARE EXTREMELY HOT WHEN THE APPLIANCE IS IN OPERATION. EXERCISE EXTREME CARE WHEN ACCESSING THIS AREA. TOUCH ONLY THE FAR ENDS OF THE LOWER CONTROL COMPARTMENT DOOR WHEN OPENING WHILE THE APPLIANCE IS HOT.**

#### OPERATION AND CARE OF YOUR APPLIANCE

1. Appliance operation may be controlled through the optional ON/OFF unit rocker switch, located in the lower control compartment, or through a remotely located optional wall switch. Separate switches may provide independent control for the forced air blower and remote fireplace operation (optional equipment).
2. When lit for the first time, this appliance will emit a slight odor for an hour or two. This is due to the "burn-in" of internal paints and lubricants used in the manufacturing process.
3. Upon each lighting of the appliance, condensation may occur and fog the inside of the glass panel. This condition will disappear shortly as the appliance heats.
4. Keep lower control compartment clean by vacuuming or brushing at least twice a year. More frequent cleaning may be required due to excessive lint from carpeting, bedding materials, etc. It is important that control compartments, burners and circulating air passageways of the appliance be kept clean.
5. Always turn off gas to pilot (millivolt appliances) before cleaning. Before relighting, refer to the lighting instructions in this manual. Instructions are also found on a pull-out panel located on the floor of the appliance.

6. Always keep the appliance area clear and free from combustible materials, gasoline and other flammable liquids.

7. Remember, the DVAR6 Millivolt appliances have a continuous burning pilot flame. Exercise caution when using products with combustible vapors.

The FAB-1600 optional blower kits are normally operated through an installed variable speed On/Off wall switch. Blower kits installed using only the thermal snap switch will come on automatically when the firebox warms due to operation and will remain on until it cools. Blower kits installed in such a way will not have speed control, will operate only at full speed and cannot be manually turned off. Kits installed with both the variable speed wall switch and the thermal snap switch in series will operate only when the appliance is on and the wall switch is toggled to on. However, the blower speed can be adjusted through its full range of operation and if desired the blower may be turned off while the appliance remains in operation.

**WARNING: OBSERVE CAUTION NEAR THE GLASS PANEL. THE APPLIANCE UTILIZES CERAMIC GLASS WHICH MAY SHATTER UNEXPECTEDLY OR IF STRUCK WITH AN OBJECT.**

**8. CAUTION: DO NOT OPERATE THIS APPLIANCE WITH A BROKEN GLASS PANEL.** Where broken glass exists, the complete glass door frame must be replaced. See the Replacement Parts Lists on page 28 and 30 for correct parts. Panel removal and reassembly instructions are described on pages 6 and 14 respectively.

9. Clean the glass only when necessary. Wipe surface with clean, dampened, soft cloth. Follow with dry, soft towel as desired. Take care not to scratch the glass surface.

**WARNING: DO NOT USE ABRASIVE CLEANERS. NEVER CLEAN THE GLASS WHEN IT IS HOT.**

#### Maintenance

The appliance and venting system should be inspected before use and at least annually by a qualified service technician.

**IMPORTANT: TURN OFF GAS AND ANY ELECTRICAL POWER BEFORE SERVICING THE APPLIANCE.**

The main burner compartment should be inspected annually for proper operation. Remove glass door frame and perform general cleaning to remove any surface build-up on pilot and burner assembly. Wipe the pilot nozzle (millivolt systems), igniter rod and hood (Figure 31). Avoid disturbing the loose ember coals on the base of the burner.

Refer to Step 12 for the glass door frame installation. When returning to service, verify proper flame characteristics as described in Step 13, refer to Figure 34.

#### Gasket Inspection

It is important that the door frame gasket be inspected at the beginning of the heating season by a qualified technician. Examine the sealing gasket for signs of deterioration or cracks. Also make sure the gasket has a positive seal, preventing combustion gases from escaping into the room. Replace the door frame gasket if necessary with material identified in the Replacement Parts Lists on page 28 and 30.

With proper care and maintenance, your appliance will provide many years of enjoyment. If you should experience any problem, first refer to the troubleshooting guide in this manual. If problem persists, contact your local service center.

## WARRANTY

Your gas appliance is covered by a one-year limited warranty. You will find a copy of the warranty in this manual. Please read the warranty to be familiar with its coverage.

Retain this manual. File it with your other documents for future reference.

## REPLACEMENT PARTS

A complete parts list is found at the end of this manual. Use only parts manufactured and/or approved by the manufacturer.

**WARNING: THE GLASS DOOR OF THIS APPLIANCE IS MANUFACTURED WITH TEMPERED GLASS (35 5/8" X 21 5/8" X 1/4" THICK) (SEE \*NOTE). DO NOT ATTEMPT TO SUBSTITUTE THE GLASS MATERIALS USED ON THIS DOOR. DO NOT ATTEMPT TO REPLACE THE GLASS DOOR OR GLASS WITH ANYTHING OTHER THAN MATERIALS SUPPLIED BY THE MANUFACTURER. THE GLASS DOOR MUST BE REPLACED AS A COMPLETE UNIT AS SUPPLIED BY THE MANUFACTURER. FAILURE TO COMPLY WITH THESE REQUIREMENTS WILL VOID THE PRODUCT WARRANTY AND LIMIT MANUFACTURER LIABILITY.**

Normally, all parts should be ordered through your distributor or dealer. Parts will be shipped at prevailing prices at time of order.

When ordering repair parts, always give the following information:

1. The model number of the appliance.
2. The serial number of the appliance.
3. The part number.
4. The description of the part.
5. The quantity required.
6. The installation date of the appliance.

*Note: 5mm thick ceramic glass is an available option from the factory. Consult your sales receipt.*

## ACCESSORY PARTS AND COMPONENT LIST FOR \_DVR6 SERIES APPLIANCES

The accessory parts and components on pages 18 and 19 are to be used only with this appliance system. Separate installation instructions are packaged with most accessories.

If you encounter any problems or have any questions concerning the installation or application of this system, please contact your distributor. For the name of your nearest distributor contact:

SFC  
4325 Artesia Avenue  
Fullerton, CA 92633  
(714) 521-7302

## ACCESSORIES AND COMPONENTS

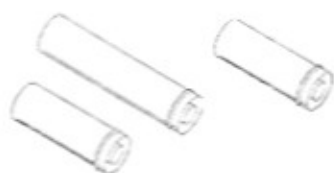

Vent Sections  
Adjustable Extension

\_DST5-12  
\_DST5-18  
\_DST5-36  
\_DST5-EXT



Vent Elbow (45°)                    \_DST5-45ELB  
Vent Elbow (90°)                 \_DST5-90ELB  
Vent Elbow (Starter)           \_DVSP5-90ELB

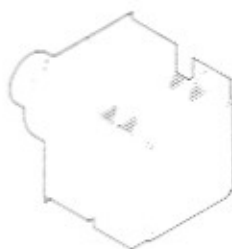

Horizontal Termination           \_DST5-HTX

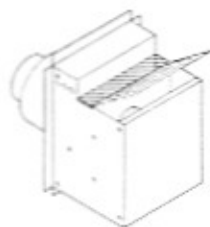

Horizontal Termination           \_DV-HTX



Firestop                                 DST5-FBY



Flexible Vent Section               \_DSF5-24

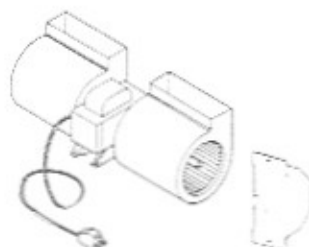

Forced Air Blower-Single Speed   \_FAB-1100  
Forced Air Blower-Variable Speed   \_FAB-1600

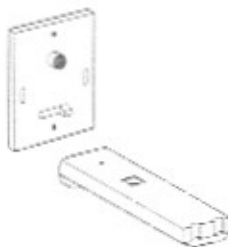

Remote Control Kit                   \_HCK

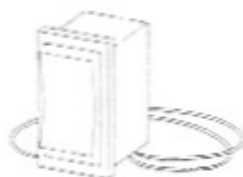

Rocker Switch Kit                   \_RS

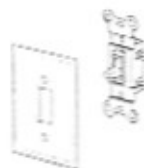

Wall Switch Kit                       \_WSK

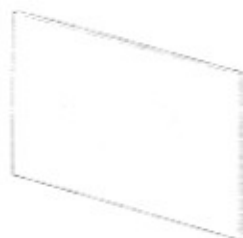

Ceramic Glass Kit                   \_CGK-6

*Note: May not be used in conjunction with the \_DAT-6-1 or \_DAT-6-4.*

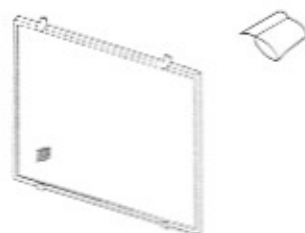

Screen Panel Kit                      \_SPK-6

*For \_DVR6-R models only.*



Brass Hood Kit                       \_PBH-6R

*For \_DVR6-C models only.*



Black Hood Kit                       \_BH-6C  
Brass Hood Kit                       \_PBH-6C

*For \_DVR6-C models only.*

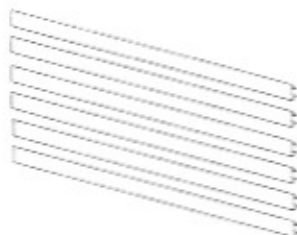

Brass Louver Kit                      \_BLK-6C

NOTE: DIAGRAMS & ILLUSTRATIONS NOT TO SCALE

For DVRS-C models only

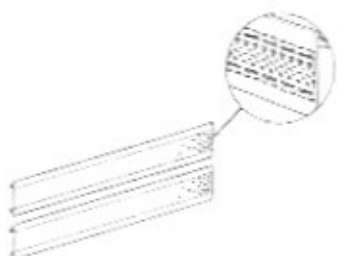

Filigree Trim Kit FTX-0

Note: May not be used in conjunction with the \_SPK-0



1-Piece Decorative Arch Frame Kit DAT-6-1

Note: May not be used in conjunction with the \_SPK-0

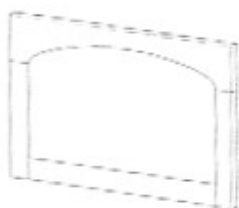

4-Piece Decorative Arch Frame Kit DAT-6-4

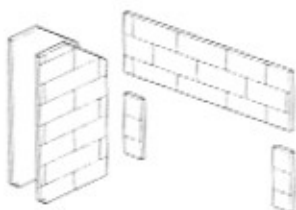

5 Piece Refractory Liner Kit RLK-6R

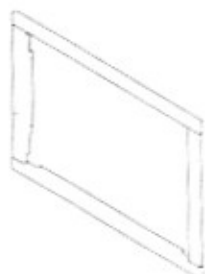

Brass Surround Kit BSK-6



Log Rack Kit DLR-6



Decorative Volcanic Stone DVS



High Altitude Orifice Kit SFC P/N 064104 Natural Propane  
SFC P/N 064087

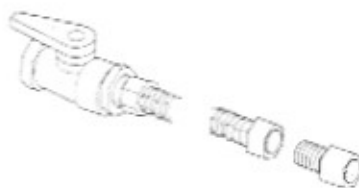

Gas Flex Line Kit GLV



Solid Log Set SLS-6



High Temperature Sealant (700°) Mill-Pac Blo



Porcelain Panel Kit PI

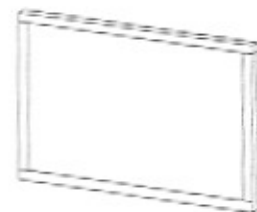

Square Trim Kit ST

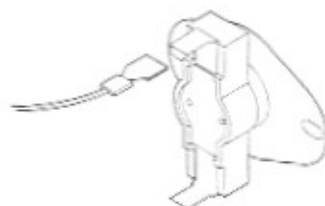

Snap Switch Kit

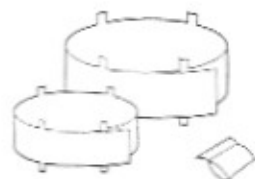

Air Restrictor Kit



Vertical Termination

DST5-VTX



Flashing

DST5-F

## LIGHTING INSTRUCTIONS — MILLIVOLT

### FOR YOUR SAFETY READ BEFORE LIGHTING

**WARNING: IF YOU DO NOT FOLLOW THESE INSTRUCTIONS EXACTLY, A FIRE OR EXPLOSION MAY RESULT CAUSING PROPERTY DAMAGE, PERSONAL INJURY OR LOSS OF LIFE.**

- A. This appliance has a pilot which must be lighted by hand. When lighting the pilot, follow these instructions exactly.
- B. **BEFORE OPERATING** smell all around the appliance area for gas. Be sure to smell next to the floor because some gas is heavier than air and will settle on the floor.
- WHAT TO DO IF YOU SMELL GAS**
- Extinguish any open flame.
  - Open windows.
  - Do not light any appliance.
  - Do not touch any electrical switches.
  - Do not use any phone in your building.
  - Immediately call your gas supplier from a neighbor's phone.
  - If your gas supplier cannot be reached, call the fire department.
- C. Use only your hand to push in or turn the gas control knob. Never use tools. If the knob will not push in or turn by hand, do not try to repair it, call a qualified service technician. Force or attempted repair may result in a fire or an explosion.
- D. Do not use this appliance if any part has been under water. Immediately call a qualified service technician to inspect the appliance and to replace any part of the control system and any gas control which has been under water.

### LIGHTING INSTRUCTIONS

1. **STOP!** Read the safety information above on this page.
2. Access the lower control compartment.
3. Turn remote wall switch to "OFF."
4. Verify main line shut-off valve is open.
5. Push in gas control knob slightly and turn clockwise to "OFF."
7. Push in gas control knob slightly and turn counterclockwise to "PILOT."
8. Push in control knob all the way and hold in. Immediately light the pilot by triggering the spark ignitor (pushing red button) until pilot lights. Continue to hold the control knob in for about 1 1/2 minutes after the pilot is lit. Release knob and it will pop back up. Pilot should remain lit. If it goes out, repeat steps 5 through 8.

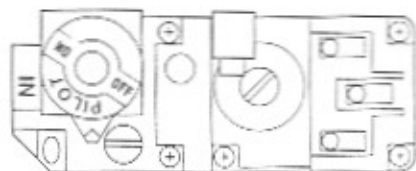

*Note: Knob cannot be turned from "PILOT" to "OFF" unless the knob is pushed in slightly. Do not force*

6. Wait five (5) minutes to clear out any gas. If you then smell gas, **STOP!** Follow "B" in the safety information above on this page. If you do not smell gas, go to the next step.
9. Turn gas control knob counterclockwise to "ON."
10. Close lower control compartment.

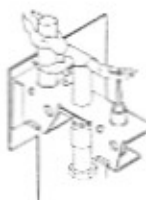

- If knob does not pop up when released, stop and immediately call your service technician or gas supplier.
- If pilot will not stay lit after several tries, turn the control knob to "OFF" and call your service technician or gas supplier.

### TO TURN OFF GAS TO APPLIANCE

1. Turn remote wall switch "OFF." The pilot will remain lit for normal service.
2. For complete shutdown, turn remote wall switch to "OFF."
3. Access the lower control compartment.
4. Depress gas control knob slightly and turn clockwise to "OFF." Do not force.
5. Close lower control compartment.



## INSTRUCTIONS D'ALLUMAGE — MILLIVOLT

POUR VOTRE SÉCURITÉ, LISEZ-LES AVANT L'ALLUMAGE

**AVERTISSEMENT : SI VOUS NE SUIVEZ PAS CES INSTRUCTIONS À LA LETTRE, IL POURRAIT S'ENSUIVRE UN INCENDIE OU UNE EXPLOSION CAUSANT DES DOMMAGES MATÉRIELS, DES BLESSURES CORPORELLES OU MÊME DES PERTES DE VIE.**

- A. Cet appareil est muni d'une veilleuse qui doit être allumée à la main. Lorsque vous allumez la veilleuse, suivez exactement ces instructions.
- B. **AVANT DE VOUS EN SERVIR**, sentez tout autour de l'appareil où il pourrait y avoir une odeur de gaz. Reniflez près du plancher car, le gaz étant plus lourd que l'air, il se dépose sur le plancher.
- VOICI CE QUE VOUS DEVEZ FAIRE SI VOUS DÉCELEZ UNE ODEUR DE GAZ:**
- Éteignez toutes les flammes nues.
  - Ouvrez les fenêtres.
  - N'allumez aucun appareil.
  - Ne touchez à aucun commutateur électrique.
  - Ne vous servez d'aucun téléphone dans votre édifice.
- C. Servez-vous uniquement de votre main pour tourner ou pour enfoncer le bouton de réglage du gaz. N'employez jamais un outil. Si le bouton refuse de tourner ou de bouger, ne tentez pas de le réparer. Appelez un technicien compétent et expérimenté. Si vous essayez de le forcer ou de le réparer, vous pourriez causer un incendie ou une explosion.
- D. Ne vous servez pas de cet appareil si l'un de ses éléments a été immergé dans l'eau. Appelez immédiatement un technicien compétent pour faire inspecter l'appareil et remplacer toute pièce du système de réglage ou commande du gaz qui a été sous l'eau.
- Appelez immédiatement votre compagnie de gaz en utilisant le téléphone d'un voisin.
- S'il vous est impossible de contacter votre compagnie de gaz, appelez le service des incendies.

## INSTRUCTIONS D'ALLUMAGE

1. **ARRÊTEZ !** Lisez les consignes de sécurité ci-dessus.
2. Ouvrez le compartiment de contrôle du bas.
3. Tournez le télérupteur mural à sa position d'arrêt "OFF".
4. Assurez-vous que la soupape d'arrêt de la canalisation principale est ouverte.
5. Enfoncéz légèrement le bouton de réglage du gaz et tournez-le dans le sens des aiguilles d'une montre jusqu'à la position d'arrêt "OFF".
7. Enfoncéz légèrement le bouton de réglage du gaz et tournez-le en sens inverse des aiguilles d'une montre jusqu'à la position de veilleuse "PILOT".
8. Enfoncéz le bouton de réglage jusqu'au fond et gardez-le enfoncé. Allumez immédiatement la veilleuse en déclenchant l'allume-gaz à étincelle (en poussant le bouton rouge) jusqu'à ce que la veilleuse s'enflamme. Continuez de tenir le bouton de réglage enfoncé pendant environ 90 secondes après l'allumage de la veilleuse. Relâchez le bouton et il sortira subitement. La veilleuse devrait rester allumée. Si elle s'éteint, répétez les étapes 5 à 8 inclusivement.

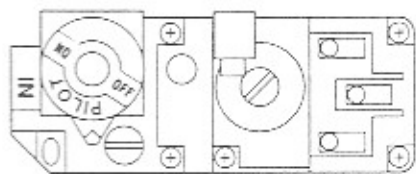

*Remarque: Il est impossible de tourner le bouton de "PILOT" à "OFF" à moins qu'il ne soit légèrement enfoncé. Ne le forcez pas.*

- Si le bouton ne sort pas automatiquement après avoir été relâché, arrêtez immédiatement et téléphonez à votre technicien de service ou à votre fournisseur de gaz.
  - Si la veilleuse refuse de rester allumée après plusieurs tentatives, tournez le bouton de réglage jusqu'à sa position d'arrêt "OFF" et téléphonez à votre technicien de service ou à votre fournisseur de gaz.
9. Tournez le bouton de réglage du gaz en sens inverse des aiguilles d'une montre jusqu'à sa position de marche "ON".
  10. Fermez le compartiment de contrôle du bas.



## POUR FERMER LE GAZ QUI ALIMENTE L'APPAREIL

1. Tournez le télérupteur mural à sa position d'arrêt "OFF". La veilleuse restera allumée jusqu'au retour du service normal.
2. Pour une fermeture complète, tournez le télérupteur mural à sa position d'arrêt "OFF".
3. Ouvrez le compartiment de contrôle du bas.
4. Enfoncéz légèrement le bouton de réglage du gaz et tournez-le dans le sens des aiguilles d'une montre jusqu'à sa position d'arrêt "OFF". Ne le forcez pas.
5. Fermez le compartiment de contrôle du bas.

## LIGHTING INSTRUCTIONS — ELECTRONIC

### FOR YOUR SAFETY READ BEFORE LIGHTING

**WARNING: IF YOU DO NOT FOLLOW THESE INSTRUCTIONS EXACTLY, A FIRE OR EXPLOSION MAY RESULT CAUSING PROPERTY DAMAGE, PERSONAL INJURY OR LOSS OF LIFE.**

- A. When lighting the appliance, follow these instructions exactly.
- B. BEFORE OPERATING smell all around the appliance area for gas. Be sure to smell next to the floor because some gas is heavier than air and will settle on the floor.
- WHAT TO DO IF YOU SMELL GAS**
- Extinguish any open flame.
  - Open windows.
  - Do not light any appliance.
  - Do not touch any electrical switches.
  - Do not use any phone in your building.
  - Immediately call your gas supplier from a neighbor's phone.
  - If your gas supplier cannot be reached, call the fire department.
- C. Use only your hand to turn the gas control lever. Never use tools. If the lever will not turn by hand, do not try to repair it, call a qualified service technician. Force or attempted repair may result in a fire or an explosion.
- D. Do not use this appliance if any part has been under water. Immediately call a qualified service technician to inspect the appliance and to replace any part of the control system and any gas control which has been under water.

### LIGHTING INSTRUCTIONS

1. **STOP!** Read the safety information above on this page.
2. Turn remote wall switch to "OFF."
3. Open lower control compartment door.
4. Verify main line shut-off valve is open.
5. Rotate the gas control lever to "OFF" (straight down). Do not force.
6. Wait five (5) minutes to clear out any gas. If you then smell gas, STOP! Follow "B" in the safety information above on this page. If you do not smell gas, go to the next step.
7. Rotate the gas control lever to "ON" (straight forward). Do not force.
8. Turn "ON" all electrical power to appliance (remote wall switch).
9. Close lower control compartment door.

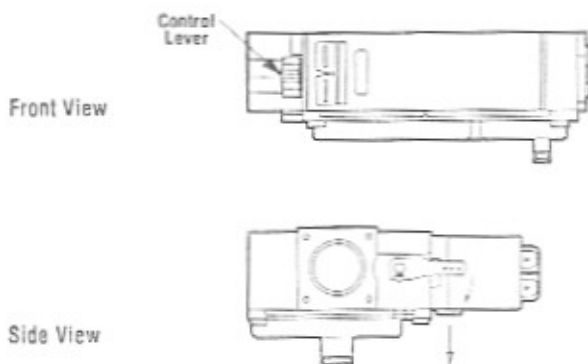

### TO SHUT OFF

1. Turn off all electrical power to the appliance (remote wall switch).

### TO TURN OFF GAS TO APPLIANCE

1. For complete shut-down, turn remote wall switch to "OFF."
2. Open lower control compartment door.
3. Rotate the gas control lever to "OFF" (straight down). Do not force.
4. Close the main line shut-off valve.
5. Close lower control compartment door.

## INSTRUCTIONS D'ALLUMAGE — ELECTRONIC

### POUR VOTRE SÉCURITÉ, LISEZ-LES AVANT L'ALLUMAGE

**AVERTISSEMENT : SI VOUS NE SUIVEZ PAS CES INSTRUCTIONS À LA LETTRE, IL POURRAIT S'ENSUIVRE UN INCENDIE OU UNE EXPLOSION CAUSANT DES DOMMAGES MATÉRIELS, DES BLESSURES CORPORELLES OU MÊME DES PERTES DE VIE.**

- A. Lorsque vous allumez l'appareil, suivez exactement ces instructions.
- B. **AVANT DE VOUS EN SERVIR**, sentez tout autour de l'appareil où il pourrait y avoir une odeur de gaz. Reniflez près du plancher car, le gaz étant plus lourd que l'air, il se dépose sur le plancher.
- VOICI CE QUE VOUS DEVEZ FAIRE SI VOUS DÉCELEZ UNE ODEUR DE GAZ**
- Éteignez toutes les flammes nues.
  - Ouvrez les fenêtres.
  - N'allumez aucun appareil.
  - Ne touchez à aucun commutateur électrique.
  - Ne vous servez d'aucun téléphone dans votre édifice.
- Appelez immédiatement votre compagnie de gaz en utilisant le téléphone d'un voisin.
- S'il vous est impossible de contacter votre compagnie de gaz, appelez le service des incendies.
- C. Servez-vous uniquement de votre main pour tourner la manette de réglage du gaz. N'employez jamais un outil. Si la manette refuse de tourner, ne tentez pas de la réparer. Appelez un technicien compétent et expérimenté. Si vous essayez de la forcer ou de la réparer, vous pourriez causer un incendie ou une explosion.
- D. Ne vous servez pas de cet appareil si l'un de ses éléments a été immergé dans l'eau. Appelez immédiatement un technicien compétent pour faire inspecter l'appareil et remplacer toute pièce du système de réglage ou commande du gaz qui a été sous l'eau.

## INSTRUCTIONS D'ALLUMAGE

1. **ARRÊTEZ !** Lisez les consignes de sécurité ci-dessus.
2. Tournez le téleinterrupteur mural à sa position d'arrêt "OFF".
3. Ouvrez la porte du compartiment de contrôle du bas.
4. Assurez-vous que la soupape d'arrêt de la canalisation principale est ouverte.
5. Tournez la manette de réglage du gaz à sa position d'arrêt "OFF" (directement en bas).
6. Attendez cinq (5) minutes pour en laisser sortir le gaz, le cas échéant. Si vous décelez une odeur de gaz, **ARRÊTEZ !** Retournez au point "B" des consignes de sécurité ci-dessus. Si vous ne remarquez aucune odeur de gaz, passez à l'étape suivante.
7. Tournez la manette de réglage du gaz jusqu'à sa position de marche "ON" (droit devant). Ne la forcez pas.
8. Ouvrez le courant électrique ("ON") qui alimente l'appareil (téleinterrupteur mural).
9. Fermez la porte du compartiment de contrôle du bas.

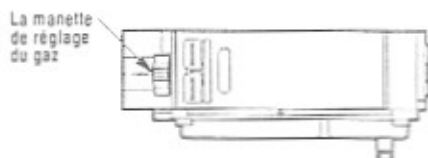

### POUR ÉTEINDRE L'APPAREIL

1. Coupez tout le courant électrique qui alimente l'appareil (téleinterrupteur mural)

## POUR FERMER LE GAZ QUI ALIMENTE L'APPAREIL

1. Pour une fermeture complète, tournez le téleinterrupteur mural à sa position d'arrêt "OFF".
2. Ouvrez la porte du compartiment de contrôle du bas.
3. Tournez la manette de réglage du gaz à sa position d'arrêt "OFF" (directement vers le bas). Ne la forcez pas.
4. Fermez la soupape d'arrêt de la canalisation principale.
5. Fermez la porte du compartiment de contrôle du bas.

REPLACEMENT PARTS LIST — MILLIVOLT

No.	DESCRIPTION	_DVR6-CMNS		_DVR6-CMPS		_DVR6-RMNS		_DVR6-RMPS	
		Part No.	Qty.	Part No.	Qty.	Part No.	Qty.	Part No.	Qty.
1.	Gas Fireplace Assembly	104902	1	104904	1	104901	1	104903	1
2.	Bar, Louver (Black)	104951	6	104951	6	104951	1	104951	1
3.	Panel, Lower, Radiant	-	-	-	-	104611	1	104611	1
4.	Panel, Upper Radiant	-	-	-	-	104591	1	104591	1
5.	Hood (Black)	-	-	-	-	104631	1	104631	1
6.	Gasket, Spud	902123	1	902123	1	902123	1	902123	1
7.	Screw	000861	3	000861	3	000861	3	000861	3
8.	Replacement Glass Panel with Gasket	064101	1	064101	1	064101	1	064101	1
9.	Door Switch	094468	1	094468	1	094468	1	094468	1
10.	Control Panel Sub Assembly	104291	1	104292	1	104291	1	104292	1
11.	Burner Assembly	104921	1	104921	1	104921	1	104921	1
12.	Log Set (Rustic)	-	-	-	-	-	-	-	-
	Front Log	902140	1	902140	1	902140	1	902140	1
	Rear Log	902139	1	902139	1	902139	1	902139	1
	Top Twig, Left	902136	1	902136	1	902136	1	902136	1
	Top Twig, Center	902137	1	902137	1	902137	1	902137	1
	Top Twig, Right	902138	1	902138	1	902138	1	902138	1
13.	Split Log Set	-	-	-	-	-	-	-	-
	Front Log	903551	1	903551	1	903551	1	903551	1
	Rear Log	903552	1	903552	1	903552	1	903552	1
	Top Twig, Left	903553	1	903553	1	903553	1	903553	1
	Top Twig, Center	903555	1	903555	1	903555	1	903555	1
	Top Twig, Right	903554	1	903554	1	903554	1	903554	1
14.	Bag of Rockwool	041172	1	041172	1	041172	1	041172	1

NOTE: These appliances come with only one log set - Item 12 or 13.

GAS CONTROLS — MILLIVOLT

No.	DESCRIPTION	_DVR6-CMNS		_DVR6-CMPS		_DVR6-RMNS		_DVR6-RMPS	
		Part No.	Qty.	Part No.	Qty.	Part No.	Qty.	Part No.	Qty.
20.	Gas Valve - Robertshaw	901196	1	901197	1	901196	1	901197	1
21.	Piezo Igniter	111061	1	111061	1	111061	1	111061	1
22.	Orifice, Standard	901693	1	094116	1	901693	1	094116	1
	Orifice, High Altitude, Kit	064059	1	064064	1	064059	1	064064	1
23.	Pilot Assembly	901047	1	901048	1	901047	1	901048	1

REPLACEMENT PARTS — MILLIVOLT

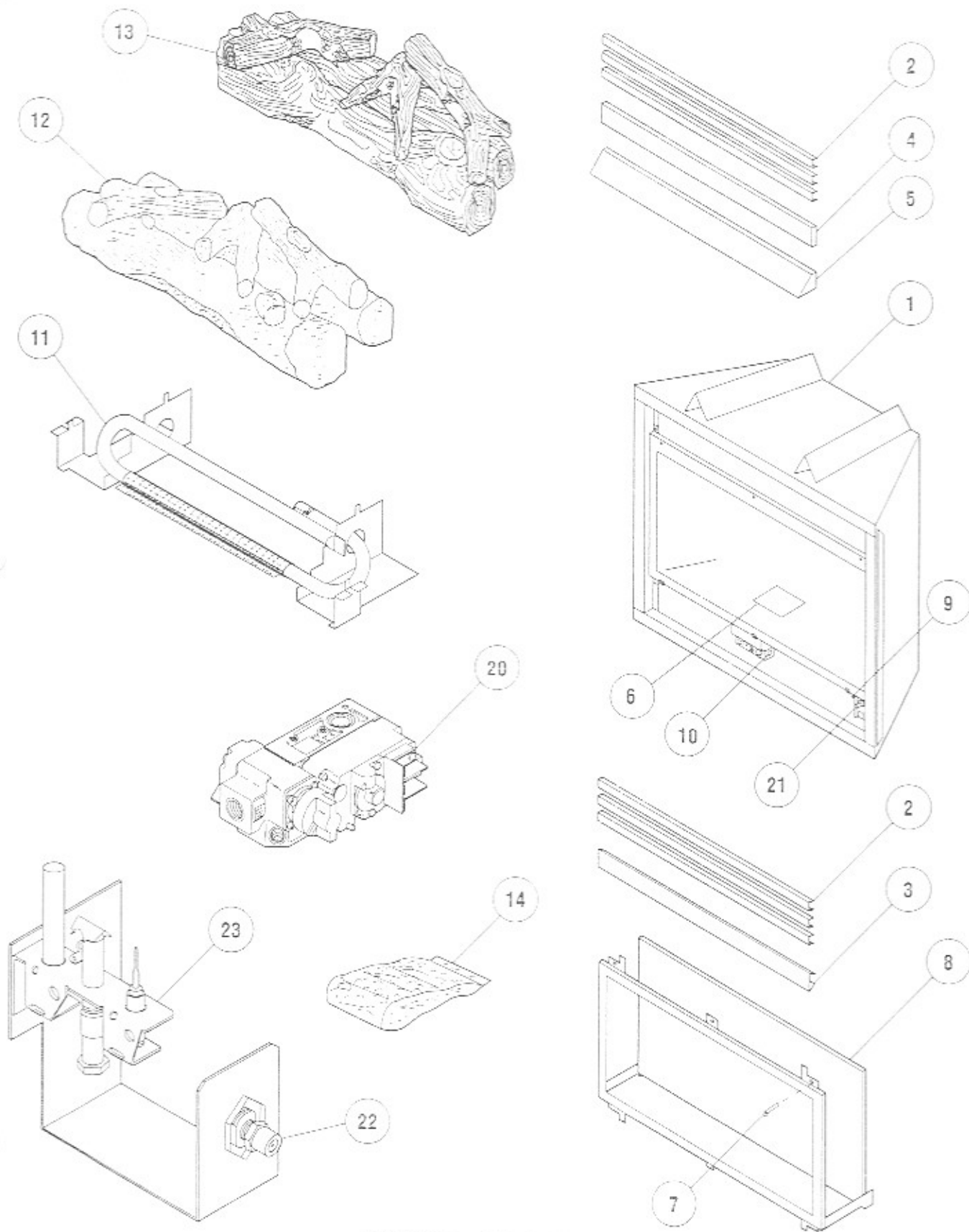

NOTE: DIAGRAMS & ILLUSTRATIONS NOT TO SCALE

### REPLACEMENT PARTS LIST — ELECTRONIC

No.	DESCRIPTION	_DVR6-CENS		_DVR6-CEPS		_DVR6-RENS		_DVR6-REPS	
		Part No.	Qty.	Part No.	Qty.	Part No.	Qty.	Part No.	Qty.
1.	Gas Fireplace Assembly	104972	1	104974	1	104971	1	104973	1
2.	Bar, Louver (Black)	104951	6	104951	6	104951	1	104951	1
3.	Panel, Lower, Radiant	-	-	-	-	104611	1	104611	1
4.	Panel, Upper Radiant	-	-	-	-	104591	1	104591	1
5.	Hood (Black)	-	-	-	-	104631	1	104631	1
6.	Gasket, Spud	902123	1	902123	1	902123	1	902123	1
7.	Screw	000861	3	000861	3	000861	3	000861	3
8.	Replacement Glass Panel with Gasket	064101	1	064101	1	064101	1	064101	1
9.	Door Switch	094468	1	094468	1	094468	1	094468	1
10.	Control Panel Sub Assembly	104311	1	104312	1	104311	1	104312	1
11.	Burner Assembly	104921	1	104921	1	104921	1	104921	1
12.	Log Set (Rustic)	-	-	-	-	-	-	-	-
	Front Log	902140	1	902140	1	902140	1	902140	1
	Rear Log	902139	1	902139	1	902139	1	902139	1
	Top Twig, Left	902136	1	902136	1	902136	1	902136	1
	Top Twig, Center	902137	1	902137	1	902137	1	902137	1
	Top Twig, Right	902138	1	902138	1	902138	1	902138	1
13.	Split Log Set	-	-	-	-	-	-	-	-
	Front Log	903551	1	903551	1	903551	1	903551	1
	Rear Log	903552	1	903552	1	903552	1	903552	1
	Top Twig, Left	903553	1	903553	1	903553	1	903553	1
	Top Twig, Center	903555	1	903555	1	903555	1	903555	1
	Top Twig, Right	903554	1	903554	1	903554	1	903554	1
14.	Bag of Rockwool	041172	1	041172	1	041172	1	041172	1

NOTE: These appliances come with only one log set - Item 12 or 13.

### GAS CONTROLS — ELECTRONIC

No.	DESCRIPTION	_DVR6-CENS		_DVR6-CEPS		_DVR6-RENS		_DVR6-REPS	
		Part No.	Qty.	Part No.	Qty.	Part No.	Qty.	Part No.	Qty.
20.	Gas Valve - Robertshaw	901198	1	901199	1	901198	1	901199	1
21.	Igniter, Electronic	901252	1	901252	1	901252	1	901252	1
22.	Transformer	098231	1	098231	1	098231	1	098231	1
23.	Igniter Controller, Electronic	901253	1	901253	1	901253	1	901253	1
24.	Orifice, Standard	901693	1	094116	1	901693	1	094116	1
	Orifice, High Altitude, Kit	064059	1	064064	1	064059	1	064064	1

REPLACEMENT PARTS — ELECTRONIC

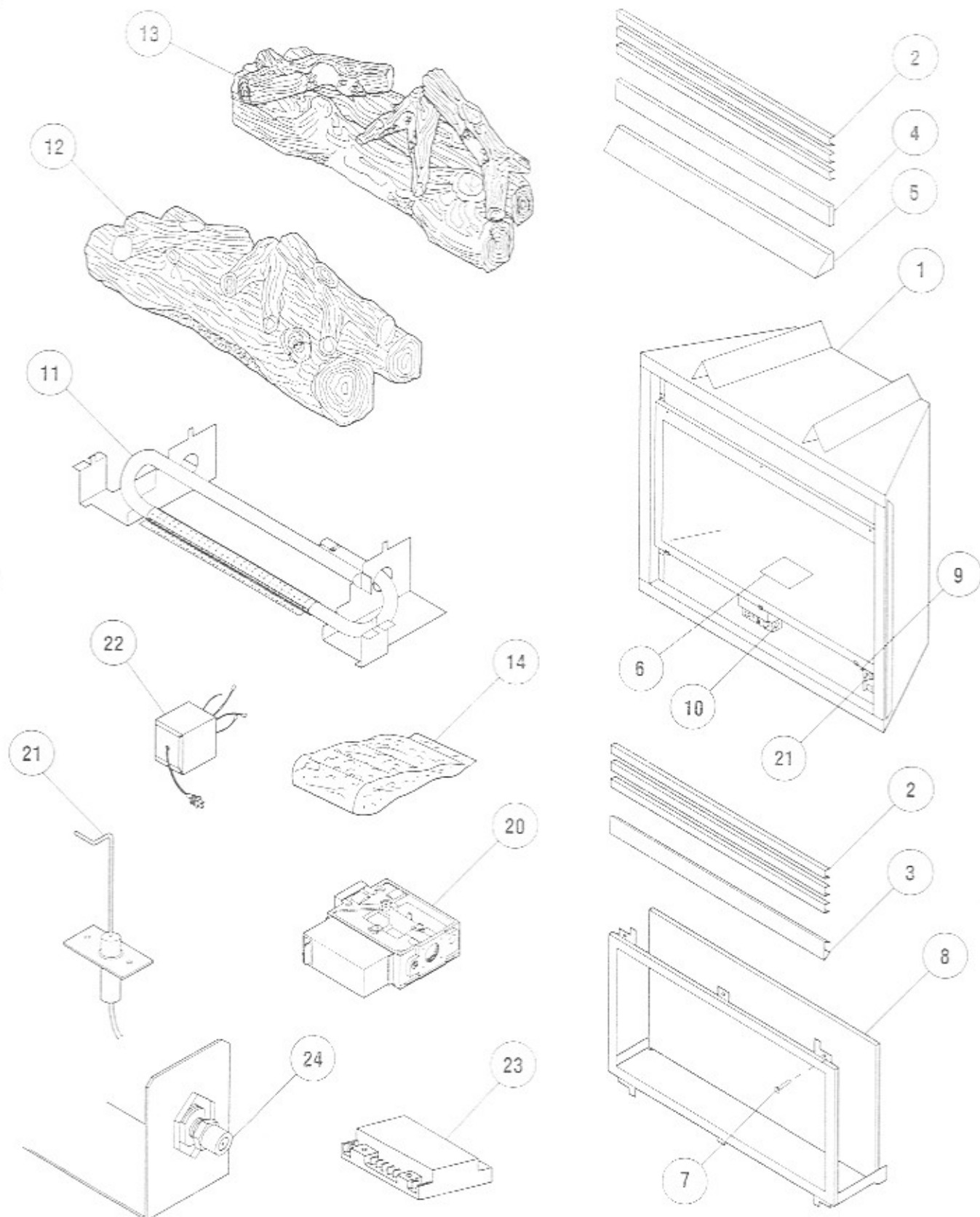

NOTE: DIAGRAMS & ILLUSTRATIONS NOT TO SCALE.

## TROUBLESHOOTING THE MILLIVOLT GAS CONTROL SYSTEM

MODELS *\_DVR6-CMNS, \_DVR6-CMPS, \_DVR6-RMNS AND \_DVR6-RMPS*

**Note:** Before troubleshooting the gas control system, be sure external gas shut off valve (located at gas supply inlet) is in the "ON" position.

SYMPTOM	POSSIBLE CAUSES	CORRECTIVE ACTION
1. Spark ignitor will not light pilot after repeated triggering of red button.	A. Defective ignitor (no spark at electrode).	Check for spark at electrode and pilot; if no spark and electrode wire is properly connected, replace ignitor.
	B. Defective or misaligned electrode at pilot (spark at electrode).	Using a match, light pilot. If pilot lights, turn off pilot and trigger the red button again. If pilot lights, an improper gas mixture caused the bad lighting and a longer purge period is recommended. If pilot will not light - check gap at electrode and pilot - should be $\frac{1}{8}$ " to have a strong spark. If gap measures $\frac{1}{8}$ ", replace pilot (Figure 31).
	C. Gas supply pressure errant.	Check inlet gas pressure. It should be within the limits as marked on the rating plate.
	D. Pilot orifice plugged.	Clean or replace pilot orifice.
2. Pilot will not stay lit after carefully following the lighting instructions.	A. Defective pilot generator (thermocouple).	Check pilot flame, it must impinge on thermocouple (Figure 31). Clean and/or adjust pilot for maximum flame impingement on thermocouple. Ensure that the connection between the valve and thermocouple are tight and secure.
3. Pilot burning, no gas to burner, Valve knob "ON," Wall Switch "ON."	A. Wall switch or wires defective.	Check wall switch and wires for proper connections. Jumper wire across terminals at wall switch, if burner comes on, replace defective wall switch. If okay, jumper wires across wall switch wires at valve, if burner comes on, wires are faulty or connections are bad.
	B. Thermopile may not be generating sufficient millivoltage.	Check thermopile with millivolt meter. Take reading at thermopile terminals of gas valve. Should read 325 millivolts minimum with optional wall switch "OFF." Replace faulty thermopile if reading is below specified minimum.
	C. Plugged burner orifice.	Check burner orifice for stoppage and remove.
	D. Defective door switch (located at lower right corner of door frame).	Remove door frame (see instructions). Remove two (2) screws from switch mounting bracket, pull switch out. Jumper wire across terminals of door switch. If burner comes on, door switch is defective. Replace.
4. Frequent pilot outage problem.	A. Pilot flame may be too low or blowing (high) causing the pilot safety to drop out.	Clean and/or adjust pilot flame for maximum flame impingement on thermocouple (Figure 31). For vertical termination vent systems taller than 10 feet, use a <i>_DV-ARK Air Restrictor Kit</i> .
5. Frequent burner outage problem.	A. Pilot flame may be too low or blowing (high) causing the valve safety to drop out.	Clean and/or adjust pilot flame for maximum flame impingement on thermopile (Figure 31). For vertical termination vent systems taller than 10 feet, use a <i>_DV-ARK Air Restrictor Kit</i> .



## TROUBLESHOOTING THE DIRECT SPARK IGNITION ELECTRONIC SYSTEM MODELS \_DVR6-CENS, \_DVR6-CEPS, \_DVR6-RENS AND \_DVR6-REPS

**Note:** Before troubleshooting, be sure that the appliance main line gas shut-off valve, the gas control valve and the wall switch are in the "ON" position.

**Important:** "ON/OFF" switch must be "OFF" before performing continuity test. Adjust multimeter to the ohm setting when performing continuity tests.

SYMPTOM	POSSIBLE CAUSES	CORRECTIVE ACTION
1. No spark.	A. Faulty transformer.	Confirm 24Vac output from transformer (red and blue leads). If no, then replace transformer.  <i>Note: Before replacing transformer, check wiring for loose connections or broken wires and repair as needed. Turn off electricity before replacing transformer.</i>
	B. Faulty door switch.	Remove wire nut from red and blue leads attached to the door switch and check for continuity. If no continuity, replace door switch.
	C. "OFF/ON" switch defective.	Disconnect the two black wires from the wire nuts. Test "ON/OFF" wall switch for continuity with a multimeter. If continuity is not indicated, switch is defective and must be replaced.  <i>Note: Before replacing "OFF/ON" switch, be sure to check wiring for loose connections or broken wires and repair as needed.</i>
	D. Ignition control module defective	If reading is not 24V at "TH" and "TR" terminals on ignition control, replace ignition control module.
	E. Ignition control or igniter defective.	Confirm that the igniter is sparking at the pilot assembly when the "ON/OFF" switch is activated. If not, undertake the following steps:  With "ON/OFF" switch "OFF," remove wire at "TR" terminal at the ignition control module. Disconnect the electrode wire from the round terminal located at the ignition control. Connect one end of a jumper wire to the metal blade of a small screwdriver. Attach the other end of the jumper wire to any metal part of the chassis. Reconnect the "TR" terminal. Position end of metal blade approximately 1/8" from the round terminal. Activate the "ON/OFF" switch. Sparking should occur between the round terminal and screwdriver blade. If sparking does occur, the ignition control module is OK. Check if the electrode wire or the igniter is faulty. If faulty, the igniter assembly should be replaced.
	F. Sparking, but not at proper location.	Electrode tip needs to be realigned to correct location. 3/16" ± 1/32" gap between electrode tip and the burner tube is desired.
2. Igniter sparking but main burners will not come on.  <i>Note: Wait at least 90 seconds after pilot lights before doing the check out for possible causes.</i>	A. Improper alignment of igniter.	Igniter must be aligned so that the top 3/4" of the igniter impinges on the burner flame path.
	B. Burner orifice plugged.	Check main burner orifice(s) for stoppage. Clean or replace.
	C. Gas valve defective.	Check for 24 volts at gas valve operator terminals "1" and "2". If there is a 24V reading and the burner does not come on, the valve operator is defective and the gas valve must be replaced.
3. Burners come "ON" but go "OFF."	A. Igniter not correctly positioned.	Check location of igniter and adjust as in Step F above. For vertical termination vent systems taller than 10 feet, use a _DV-ARK Air Restrictor Kit.

## Select Series Limited Lifetime Warranty

### THE WARRANTY

Superior Fireplace Company ("SFC") warrants your Select Series Vented Decorative Gas Appliance or your Select Series AFUF Room Heater ("Product") to be free from defects in materials and workmanship at the time of manufacture. After installation, if any of the components manufactured by SFC in the Product are found to be defective in materials or workmanship during the lifetime of the original owner and while the Product remains at the site of the original installation, SFC will, at its option, replace or repair the defective components at no charge to you. SFC will also pay for reasonable labor costs incurred in replacing or repairing such components for a period of one year from the date of installation. **THESE ARE EXCLUSIONS AND LIMITATIONS to this Limited Warranty as described herein.**

### EXCLUSIONS AND LIMITATIONS

This Limited Warranty applies to the original purchaser, but only if the Product is installed in the United States or Canada and only if operated in accordance with the printed instructions accompanying the Product and in compliance with all applicable installation and building codes and good trade practices. If repair or replacement is not commercially practical, SFC will, at its option, refund the purchase price of the SFC Product.

Vent components, brass components and paint are excluded from this Limited Warranty. The following components are NOT warranted for the lifetime of the original purchaser but are warranted as follows:

- Controls - repair or replacement for one year from the date of installation
- Glass - repair or replacement for one year from the date of installation
- Gaskets - repair or replacement for one year from the date of installation
- Logs - repair or replacement for one year from the date of installation

We will not be responsible for: (a) damages caused by accident, riot, fire, flood or act of God; (b) damages caused by abuse, negligence, misuse, or unauthorized alteration or repair of the Product affecting its stability or performance (The Product must be subject to normal use. The Product is designed to burn either natural or propane gas only. Burning conventional fuels such as wood, coal or any other solid fuel will cause damage to the Product, will produce excessive temperatures and will result in a fire hazard); (c) damages caused by failing to provide proper maintenance and service in accordance with the instructions provided with the Product; (d) damages, repairs or inefficiency resulting from faulty installation or application of the Product.

This Limited Warranty covers only parts and labor as provided herein. In no case shall SFC be responsible for materials, components or construction which are not manufactured or supplied by SFC or for the labor necessary to install, repair or remove such materials, components or construction. All replacement or repair components will be shipped F.O.B. the nearest SFC factory.

### LIMITATION ON LIABILITY

It is expressly agreed and understood that SFC's sole obligation and purchaser's exclusive remedy under this warranty, under any other warranty, expressed or implied, or in contract, tort or otherwise, shall be limited to replacement, repair, or refund, as specified herein.

In no event shall SFC be liable for any incidental or consequential damages caused by defects in the Products, whether such damage occurs or is discovered before or after replacement or repair, and whether such damage is caused by SFC's negligence. SFC has not made and does not make any representation or warranty of fitness for a particular use or purpose, and there is no implied condition of fitness for a particular use or purpose.

We make no express warranties except as stated in this Limited Warranty. The duration of any implied warranty is limited to the duration of this expressed warranty.

No one is authorized to change this Limited Warranty or to create for us any other obligation or liability in connection with the Product. Some states and provinces do not allow the exclusion or limitation of incidental or consequential damages, so the above limitations or exclusions may not apply to you. The provisions of this Limited Warranty are in addition to and not a modification of or subtraction from any statutory warranties and other rights and remedies provided by law.

### INVESTIGATION OF CLAIMS AGAINST WARRANTY

SFC reserves the right to investigate any and all claims against this Limited Warranty and to decide upon method of settlement.

### SFC NOT RESPONSIBLE FOR WORK DONE WITHOUT WRITTEN CONSENT

To receive the benefits and advantages described in this Limited Warranty, the appliance must be installed and repaired by a licensed contractor approved by SFC. Contact SFC at the address provided herein to obtain a listing of approved dealers. SFC shall in no event be responsible for any warranty work done by a contractor that is not approved without first obtaining SFC's prior written consent.

### HOW TO REGISTER A CLAIM AGAINST WARRANTY

In order for any claim under this Warranty to be valid, SFC must be notified of the claimed defect in writing or by telephone as soon as reasonably possible after the defect is discovered. Notices should be directed to SFC, attention Customer Service Department, 4325 Artesia Avenue, Fullerton, CA 92633. Telephone 714-521-7302. Claims in writing should include the date of installation and a description of the defect.

SFC reserves the right to make changes at any time, without notice, in design, materials, specifications, prices and also to discontinue colors, styles and products. Consult your local distributor for fireplace code information.

Printed in U.S.A. © 1996 by Superior Fireplace Company

P/N 902147 REV. C 8/97

**SFC**

4325 Artesia Avenue • Fullerton, CA 92633

714-521-7302

503 East Reelfoot Avenue • Union City, TN

901-885-7621