

Make sure the Pressure Boost Kit is reassembled in the correct order with the shoulder of the Brass Backing Ring (#4) facing against the O-Ring (#5).

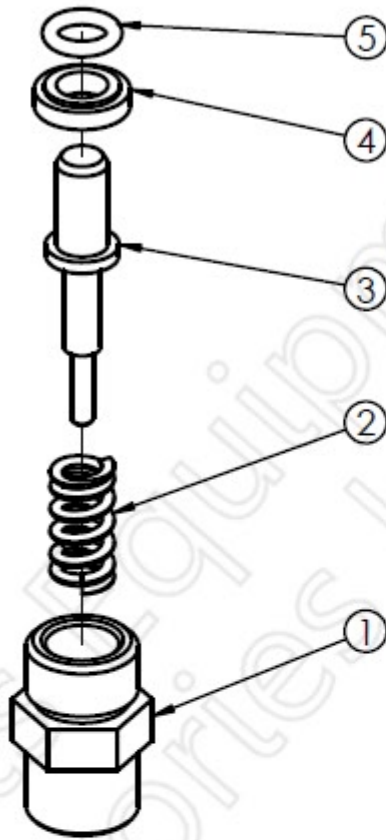

## PRESSURE BOOST VALVE KIT

ITEM	QTY	DESCRIPTION
1	1	VALVE CAP, PRESSURE BOOST
2	1	SPRING, BOOST VALVE
3	1	VALVE, PRESSURE BOOST
4	1	BACK RING
5	1	O-RING