

# HEAT-STREAM®

## *User's Manual & Operating Instructions*

### *Model Numbers*

HS- 45-KFA / HS-70T-KFA / HS-125T-KFA / HS-175T-KFA / HS-215T-KFA



**CONSUMER: READ AND SAVE THESE INSTRUCTIONS**

**⚠ DANGER** **GENERAL HAZARD WARNING:**  
**READ AND UNDERSTAND ALL OF THE INSTRUCTIONS IN THIS MANUAL BEFORE ASSEMBLING, STARTING, OR SERVICING THE HEATER.** Be sure to comply with the instructions and warnings provided with this heater. Failure to comply can result in fire or explosion that can cause property loss, bodily injury, or loss of life. Only persons who can follow and understand these instructions should operate or service this heater. If you need heater info; such as an operating manual, labels, etcetera, contact Pinnacle Products International at 800-641-6996.

**⚠ DANGER** **NOT FOR USE IN RESIDENTIAL LIVING AREAS OR IN ENCLOSED SPACES WITHOUT ADEQUATE VENTILATION. TO BE USED IN WELL VENTILATED COMMERCIAL / INDUSTRIAL OCCUPANCIES.** This is an unvented portable heater that uses air (Oxygen) from within the area in which it is used. Failure to provide adequate combustion and ventilation air will result in asphyxiation, carbon monoxide poisoning, bodily injury or death. Refer to "Ventilation" on Page 7.

© 2013 Pinnacle Products International, Inc.  
668 Stony Hill Road #302 Yardley, PA 19067 USA • Toll Free (800)-641-6996  
Fax: (215)-891-8461 • Web: [www.Heat-Stream.com](http://www.Heat-Stream.com) • Email: [info@pinnacleint.com](mailto:info@pinnacleint.com)

**PINNACLE**  
INTERNATIONAL

701000355-13

## Table Of Contents

Safety Information.....	1-2	Maintenance.....	9-11
Features and Specifications.....	3	Wiring Diagram.....	11
45-KFA and 70T-KFA Assembly.....	4	Troubleshooting Guide.....	12
125T/ 175T / 215T-KFA Assembly.....	5-6	Exploded View.....	13
Operation.....	7-6	Parts List.....	14
Ventilation.....	7	Warranty.....	Back Cover

## Safety Information

**▲ WARNING FIRE, BURN, INHALATION AND EXPLOSION HAZARD.** Keep combustibles such as; building materials, paper or cardboard a safe distance away from the heater as recommended by these instructions. Never use the heater in spaces which contain products such as; gasoline, solvents, paint thinners, dust particles, volatile or airborne combustibles or any unknown chemicals. This is an unvented portable heater. It uses air (Oxygen) from the area in which it is used. Adequate combustion and ventilation air must be provided. Refer to "Ventilation" on page 7. Bulk fuel storage should be a minimum of 25 feet from heater.

**▲ WARNING DO NOT OPERATE THIS HEATER UNTIL YOU HAVE READ AND THOROUGHLY UNDERSTAND THESE SAFETY AND OPERATING INSTRUCTIONS.**

Failure to comply with the precautions and instructions provided with this heater can result in death, serious bodily injury, property loss or damage from the hazards of fire, soot production, explosions, burns, asphyxiation or carbon monoxide poisoning. Only persons who can read and understand these instructions should use or service this heater.

**▲ WARNING DO NOT START THE HEATER WHEN EXCESS OIL HAS ACCUMULATED.**

**▲ WARNING DO NOT START THE HEATER WHEN THE CHAMBER IS HOT.**

**▲ WARNING CALIFORNIA RESIDENTS:** This product contains chemicals, including lead, known to the State of California to cause birth defects or other reproductive harm.

***Wash hands after handling.***

**MASSACHUSETTS RESIDENTS:** Massachusetts state law prohibits the use of this heater in any building which is used in whole or in part for human habitation. Use of this heating device in Massachusetts requires local fire department permit (M.G.L.C. 148, Section 10A).

**NEW YORK CITY RESIDENTS:** The New York City Fire Code prohibits the storage, handling and use of kerosene fueled heaters for space heating. Any person violating that provision may be punished by a fine up to \$10,000 and a term of imprisonment of up to 6 months.

**THE INSTALLATION OF THIS HEATER SHALL COMPLY WITH THE REGULATIONS OF THE AUTHORITIES HAVING JURISDICTION.**

***i* Look for this icon throughout the manual for helpful tips on how to assemble, use and clean your KFA Heater.**

## Safety Information

**▲ WARNING RISK OF INDOOR AIR POLLUTION!**

The products described in this manual are kerosene direct-fired, forced air heaters. Kerosene forced air heaters are primarily intended for use for temporary heating of buildings under construction, alteration or repair. Direct-fired means that all of the combustion products of the heater enter the heated space. This appliance is rated at 98% combustion efficiency, but does produce small amounts of carbon monoxide.

**▲ DANGER CARBON MONOXIDE POISONING MAY LEAD TO DEATH!**

Carbon monoxide is toxic. Humans can tolerate only small amounts of carbon monoxide and so precautions should be taken to provide proper ventilation. Failure to provide proper ventilation in accordance with the instructions in this manual can result in death.

People with breathing problems should consult a physician before using this heater.

Early signs of carbon monoxide poisoning resemble the flu. Symptoms of improper ventilation / carbon monoxide poisoning are:

**Headache • Dizziness • Nausea • Dry Mouth  
Sore Throat • Burning of Nose and Eyes**

If you experience any of these symptoms: **GET FRESH AIR AT ONCE!** Have your heater serviced and check for proper ventilation. Some people are more affected by carbon monoxide than others. These include: pregnant women, those with heart or lung problems, anemia or those under the influence of alcohol or at high altitudes.

**Use this heater in only well ventilated areas!  
Provide at least a three square foot (2,800 sq cm) opening of outside air for every 100,000 Btu / Hr heater rating. Refer to "Ventilation" on page 7 for further instructions.**

**▲ WARNING RISK OF ELECTRIC SHOCK!**

ALWAYS use only the electrical power (voltage and frequency) specified on the model plate of the heater.

ALWAYS use only three-prong, grounded outlet and extension cord.

ALWAYS use only 14 AWG or better extension cord.

ALWAYS unplug the heater when not in use.

ALWAYS install the heater so that it is not directly exposed to water spray, rain, dripping water, or wind.

**▲ WARNING RISK OF BURNS, FIRE AND EXPLOSION!**

NEVER use fuels such as gasoline, benzene, paint thinners or other oil compounds in this heater.

NEVER refill the heater's fuel tank while the heater is operating or still hot. This heater is **EXTREMELY HOT** while in operation.

NEVER block air inlet (rear) or air outlet (front).

NEVER use duct work in front or rear of heater.

NEVER move or handle heater while still hot.

NEVER transport heater with fuel in tank.

NEVER use with an external fuel tank.

**▲ WARNING CAUTION! HOT WHILE IN OPERATION. DO NOT TOUCH. KEEP CHILDREN, ANIMALS, CLOTHING AND COMBUSTIBLES AWAY FROM HEATER.**

Keep all combustible materials away from this heater.

**Minimum Clearance From Combustibles**

	45-KFA	70T-KFA	125T-KFA	175T-KFA	215T-KFA
Top	4 ft.	4 ft.	4 ft.	4 ft.	4 ft.
Sides	4 ft.	4 ft.	4 ft.	4 ft.	4 ft.
Front	8 ft.	8 ft.	8 ft.	8 ft.	10 ft.

ALWAYS locate heater on a stable and level surface.

If your heater is equipped with a thermostat, once it is plugged in, it can start at anytime in accordance with the thermostat setting.

**Specifications**

Model #	HS-45-KFA	HS-70T-KFA	HS-125T-KFA	HS-175T-KFA	HS-215T-KFA
Rating: Btu/Hr	45,000	70,000	125,000	175,000	215,000
Fuel Consumption: Gal/Hr	.35	.53	.95	1.33	1.63
Fuel Tank Capacity: Gallons	5.0	5.0	10.0	13.0	13.0
Pump Pressure: psi	3.0	4.0	5.0	7.5	9.0
Volts: AC/Hz	120VAC / 60Hz	120VAC / 60Hz	120VAC / 60Hz	120VAC / 60Hz	120VAC / 60Hz
Amps	1.4	1.5	2.3	2.7	2.8
Phase	Single	Single	Single	Single	Single

Specifications subject to change without notice.

**Features**

Models: HS-45-KFA / HS-70T-KFA

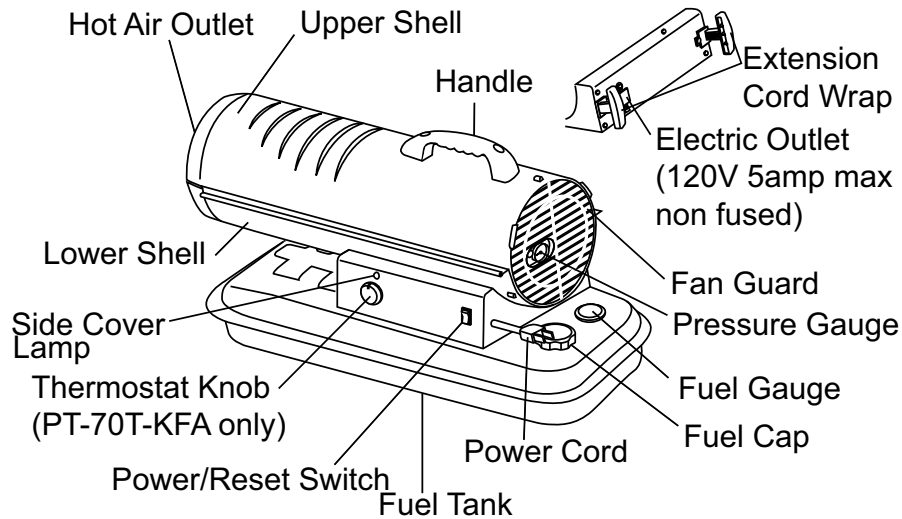

Figure 1

Models: HS-125T-KFA / HS-175T-KFA / HS-215T-KFA

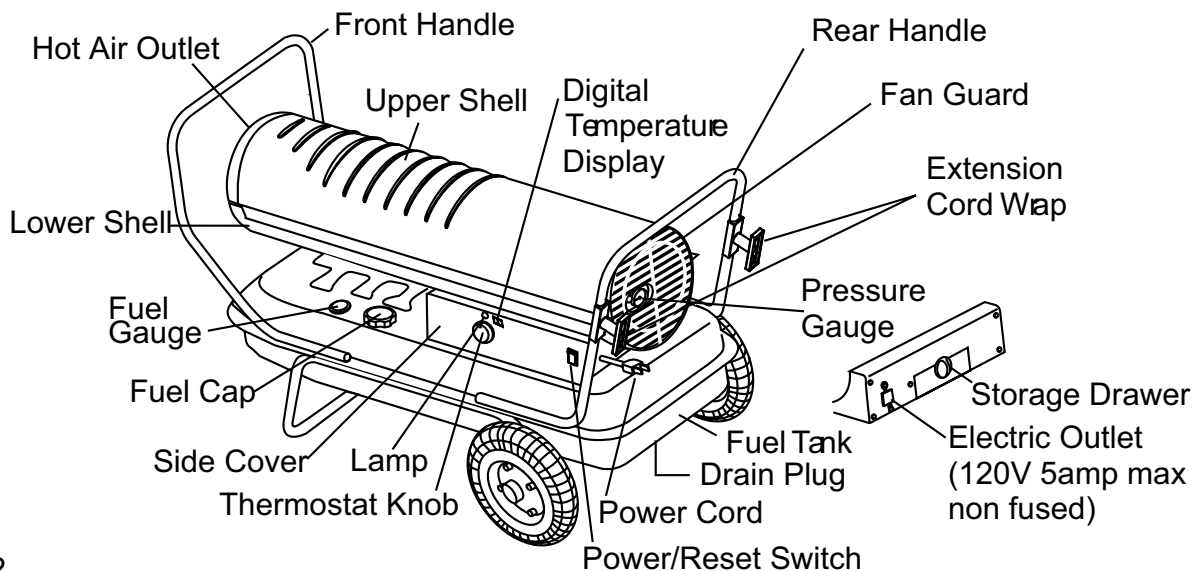

Figure 2

## Assembly Instructions

**Models: HS-45-KFA / HS-70T-KFA**

- Remove the heater and all packaging materials from the shipping carton

**Note: Save the box and packaging materials for future storage.**

### What's In The Box

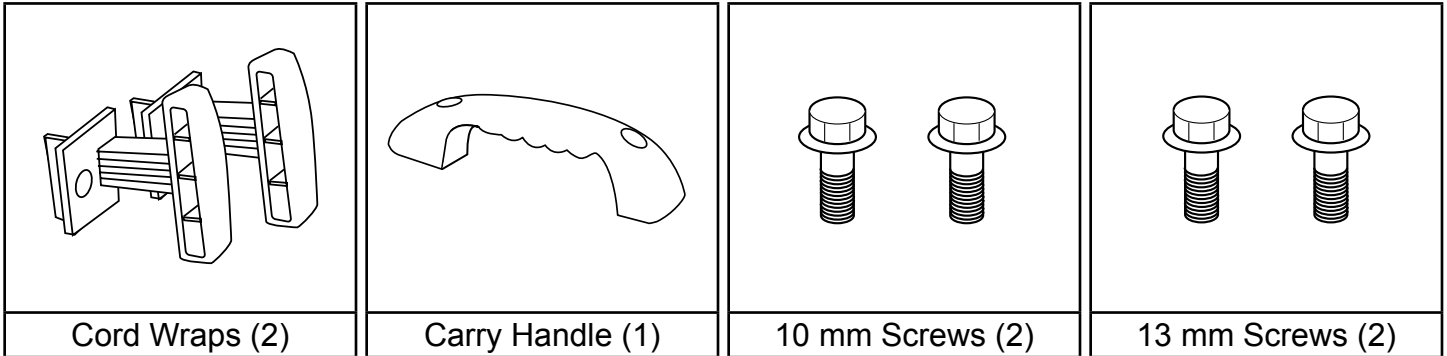

### Missing Parts? Please Call 800-641-6996 For Assistance

#### Carry Handle Assembly

1. Align holes in the upper housing with the 2 holes in the handle as shown in Figure 3.
2. Insert screws (13 mm) and tighten firmly.

#### Cord Wrap Assembly

1. Insert tabs into square slots in shell support and line up screw holes as shown in Figure 4.
2. Insert screws (10 mm) and tighten firmly.

#### Tools Needed:

- Phillips Head Screw Driver

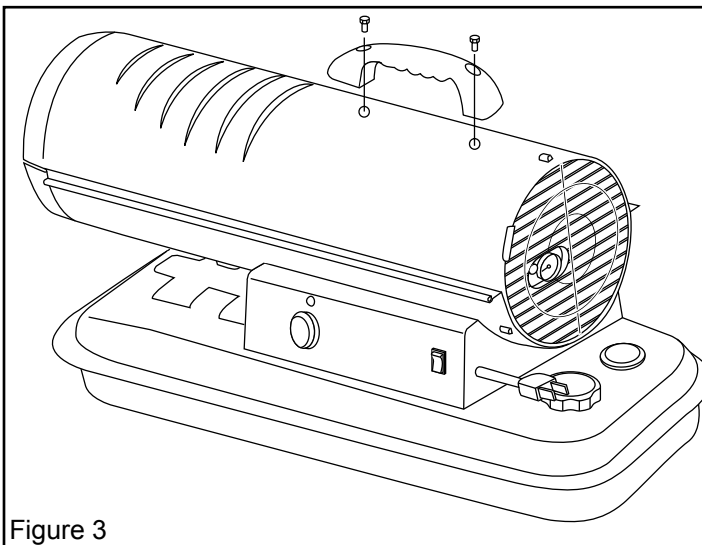

Figure 3

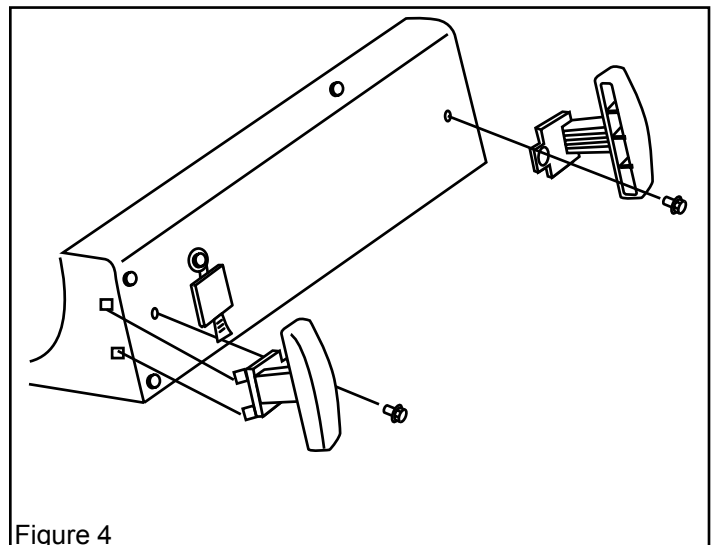

Figure 4

**Assembly Instructions**

**Models: HS-125T-KFA / HS-175T-KFA / HS-215T-KFA**

- Remove the heater and all packaging materials from the shipping carton.

- Phillips Head Screw Driver
- 8 mm open end wrench
- 19 mm open end wrench

***i* Tip: Be sure to remove the axle from the side of the Styrofoam packaging.**

***i* Tip: Use a power screwdriver and locking wrench for easier assembly.**

**Tools Needed:**

**What's In The Box**

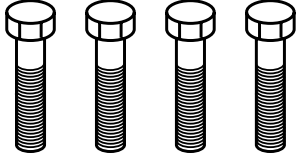
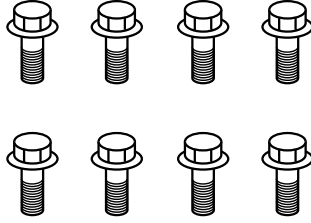
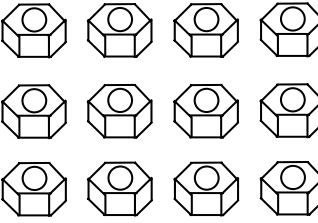
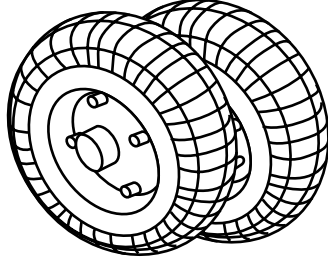
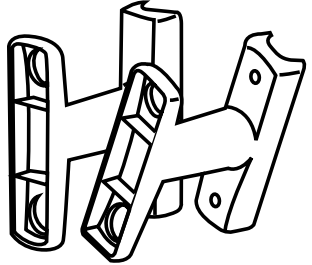
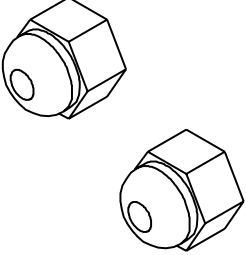
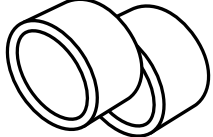
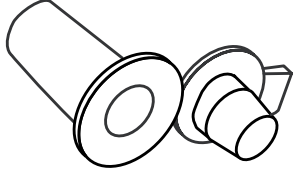
			
<p>50 mm Screws (4)</p>	<p>30 mm Screws (8)</p>	<p>8 mm Nuts (12)</p>	<p>Tires (2)</p>
			
<p>Cord Wraps (2)</p>	<p>Axle Nuts (2)</p>	<p>Spacers (2)</p>	<p>Spare Drain Plug (1)</p>

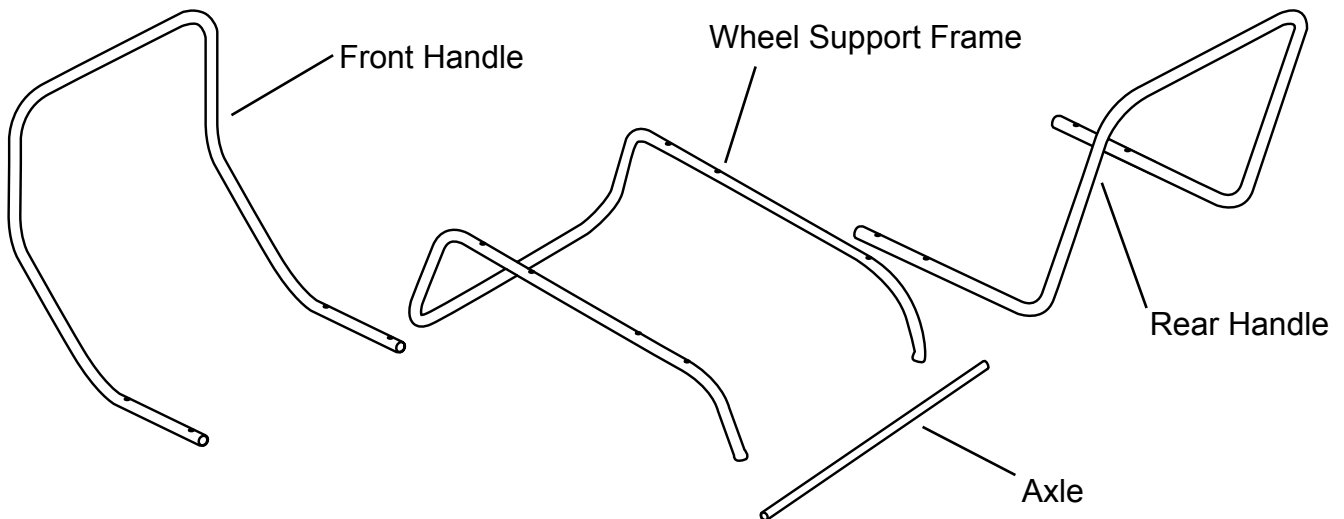

**Missing Parts? Please Call 800-641-6996 For Assistance**



## Assembly Instructions

**Models: HS-125T-KFA / HS-175T-KFA / HS-215T-KFA**

1. Insert axle through holes in wheel support.
2. Slide spacer onto axle.
3. Slide wheel onto axle with the air valve facing out and hold in place with the axle nuts. (See Figure 5).
9. Remove the wheels to secure the second set of screws through the rear handle.
10. Secure the rear handle with (2) short screws (30 mm) and (2) nuts and tighten firmly
11. Replace wheels with the valve facing out and tighten with the wheel nuts.
12. Tilt heater back down onto wheels and check all screws and nuts to make sure they are secure.

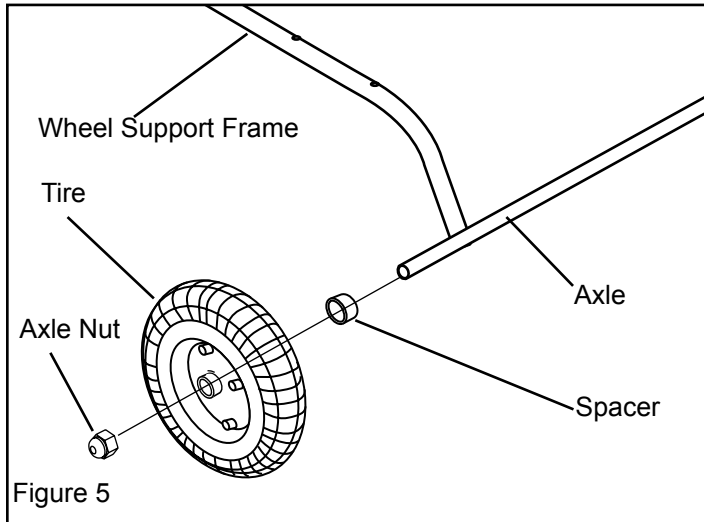

Figure 5

**i** **Tip: Do not tighten the nuts fully. You will need to remove the wheels in a later step.**

4. Place heater on wheel support and line up holes on the fuel tank lip.
5. Attach front handle with (2) long screws (50 mm) and (2) nuts through the second hole from the front on both sides of the tank lip and wheel support frame and tighten firmly.
6. Insert (2) short screws (30 mm) through the first hole from the front in the tank lip and tighten firmly. Make certain all (4) screws are secure.
7. Attach rear handle with (2) long screws (50 mm) and (2) nuts through the third hole from the rear of the heater on either side. (See Figure 6)

**i** **Tip: You will secure the back of the rear handle in a later step by tilting the heater up the front handle as shown in figure 7**

8. Tilt the heater up gently so it is resting on the front handle.

**NOTE: DO NOT do this if there is fuel in the tank.**

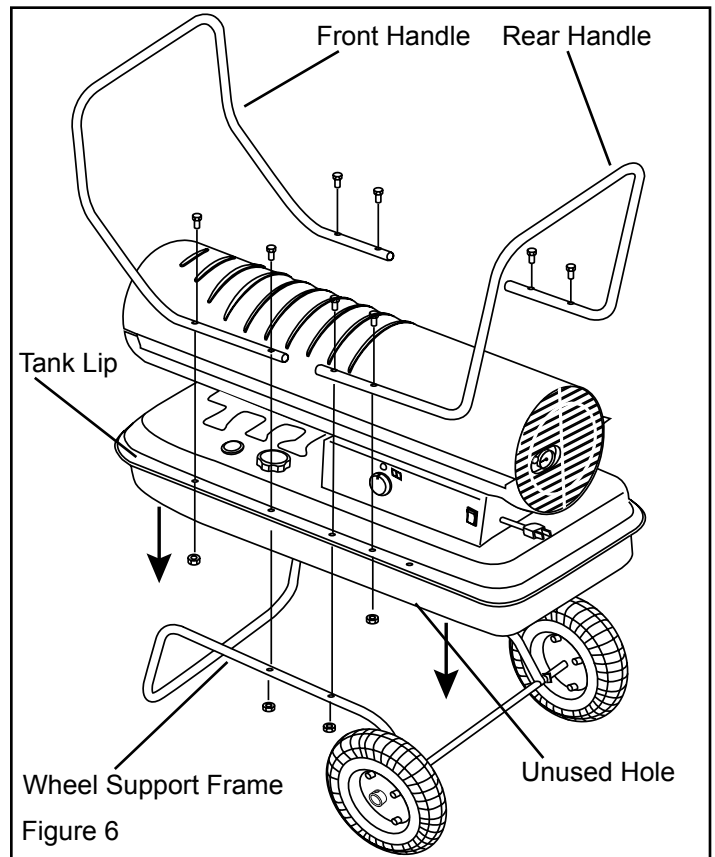

Figure 6

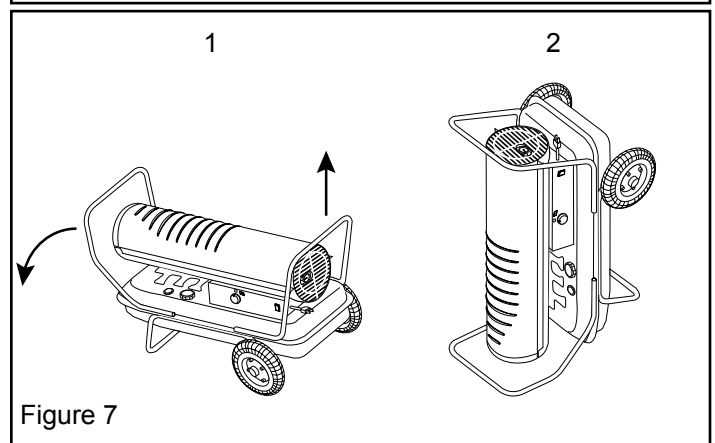

Figure 7

## Operation

### Fueling The Heater:

#### **Kerosene (1-K)**

For optimal performance of this heater, it is strongly suggested that 1-K kerosene be used. 1-K kerosene has been refined to virtually eliminate contaminants, such as sulfur, which can cause a rotten egg odor during the operation of the heater. Using diesel fuel can cause excess soot production. Do not use Bio-Diesel as this fuel will damage your heater's seals and filter.

- CSA certified for use with 1-K kerosene, no. 1 & no. 2 diesel, JP8/Jet A Fuel, no. 1 and no. 2 fuel oil.

DO NOT use any fuel that is not approved above.

**▲ DANGER** NEVER REFUEL THIS HEATER WHILE IT IS HOT OR OPERATING. FIRE OR EXPLOSION COULD RESULT.

**▲ CAUTION** NEVER FILL THE FUEL TANK INDOORS. ALWAYS FILL THE TANK OUTDOORS. BE SURE THAT THE HEATER IS ON LEVEL GROUND WHEN FUELING, AND NEVER OVERFILL THE TANK.

**▲ WARNING** DO NOT USE GASOLINE OR CRANKCASE DRAININGS.

- NEVER use fuel such as, benzene, alcohol, white glass, camp stove fuel, paint thinners, or other oil compounds in this heater. THESE ARE VOLATILE FUELS THAT CAN CAUSE A FIRE OR EXPLOSION.
- NEVER store kerosene in the living space. Kerosene should be stored in a well ventilated area outside the living area.
- NEVER store kerosene in direct sunlight or near a source of heat.
- NEVER use kerosene that has been stored from one season to the next. Kerosene deteriorates over time. OLD KEROSENE WILL NOT BURN PROPERLY IN THIS HEATER.

**NOTE:** Kerosene should only be stored in a blue container that is clearly marked "Kerosene." Never store kerosene in a red container. Red is associated with gasoline.

### Ventilation:

- Risk of indoor air pollution and Carbon Monoxide Poisoning. Use heater only in well ventilated areas.
- Refer to Safety Information on pages 1-2 for information about Carbon Monoxide Poisoning.

**▲ DANGER** CARBON MONOXIDE POISONING MAY LEAD TO DEATH!

- ALWAYS provide a fresh air opening in the heated space of at least three square feet (2,800 sq. cm) for each 100,00 Btu / Hr. of heater output. Provide a larger opening if more heaters are being used. As an example, a 125T-KFA will require:
  - A two car garage door open 6 inches or
  - A single car garage open 9 inches, or
  - Two (2) 32" windows open 15"

Minimum Ventilation Opening Needed				
45-KFA	70T-KFA	125T-KFA	175T-KFA	215T-KFA
1.4 ft. <sup>2</sup>	2.1 ft. <sup>2</sup>	3.8 ft. <sup>2</sup>	5.3 ft. <sup>2</sup>	6.5 ft. <sup>2</sup>
1250 cm <sup>2</sup>	1950 cm <sup>2</sup>	3480 cm <sup>2</sup>	3760 cm <sup>2</sup>	5990 cm <sup>2</sup>

### Electrical Outlet:

- Never plug an appliance with more than a 5 amp rating into this outlet (See Figure 8).
- Always keep outlet covered when not in use.

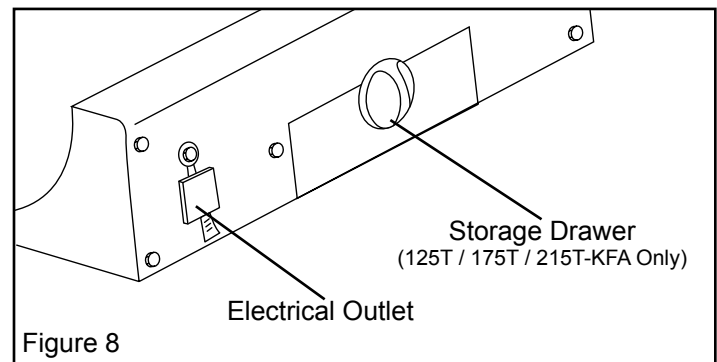



## Operation

### Starting the Heater: (Ignition)

1. Fill the tank with kerosene or other approved fuel until needle on fuel gauge points to "F".
2. Replace fuel cap and tighten firmly.
3. Connect the heater to a three prong (grounded) power source. You must use a three prong (grounded) extension cord that is at least 6 feet long and is a minimum of 14 AWG rating.

#### Model 45-KFA:

1. Complete steps 1-3 above.
2. Move power switch to "On" position. The power indicator light will illuminate and the heater will ignite. (See Figure 9)

**NOTE:** If if the heater still does not ignite, refer to "Troubleshooting Guide" on page 12.

***i* TIP:** *If the heater does not ignite; move switch to "Off" position, check steps 1-3 above and then move switch to "On" position.*

#### Stopping / Restarting Heater:

- To stop the heater, move the power switch to the "Off" position and unplug the power cord.
- To restart the heater; wait 10 seconds and follow ignition steps.

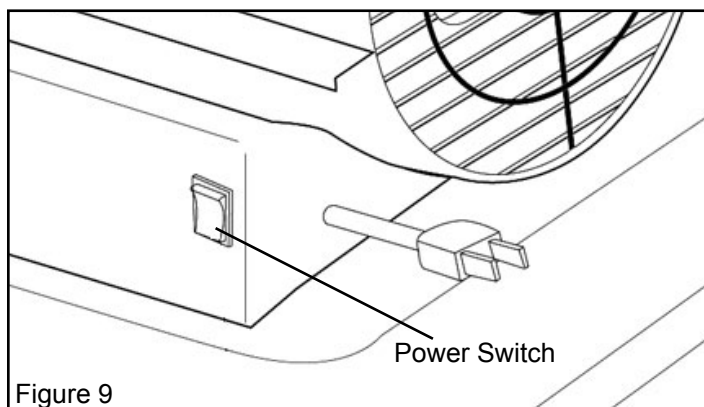

Figure 9

#### Models 70T-KFA / 125T-KFA / 175T-KFA / 215T-KFA:

1. Complete "starting heater ignition" steps 1-3 above
2. Turn thermostat control knob to desired temperature setting. The thermostat set range is from 40 °F to 110 °F.
3. Move power switch to "On" position. The power indicator light and room temperature display will illuminate and heater will ignite. (See Figure 10)

***i* TIP:** *If the heater does not ignite, the thermostat may be set too low. Turn the control knob to a higher setting until the heater ignites. If the heater does not ignite; move switch to "Off" position, check steps 1-3 above and then move switch to "On" position.*

**NOTE:** If if the heater still does not ignite, refer to "Troubleshooting Guide" on page 12.

**NOTE:** The 45-KFA and 70T-KFA do not have a room temperature display feature.

The room temperature display will indicate the following:

- When the temperature is less than 0 °F the display says "LO".
- When the temperature is more that 99 °F the display says "HI".
- Between 0 °F and 99 °F the display shows actual temperature.

#### Stopping / Restarting Heater:

- To stop the heater, move the power switch to the "Off" position and unplug the power cord.
- To restart the heater; wait 10 seconds and follow ignition steps.

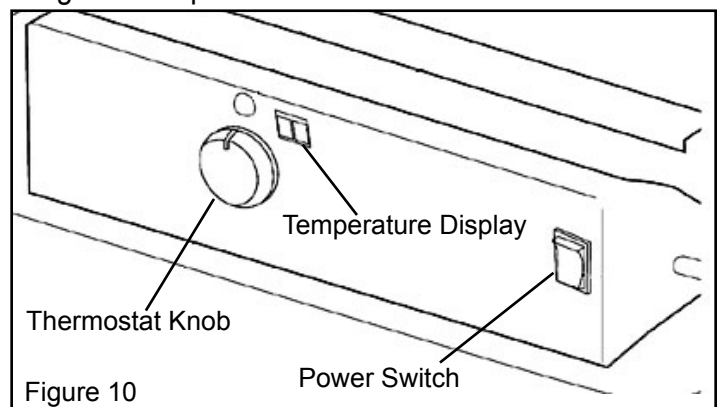

Figure 10

## Maintenance

### Long Term Storage:

#### **Models 45-KFA / 70T-KFA:**

1. Use an approved siphon to drain fuel through the fuel cap opening.

#### **Models 125T-KFA / 175T-KFA / 215T-KFA:**

1. Drain fuel through the drain plug in the bottom of the fuel tank.
2. To remove the drain plug, pull the plug grip downward and remove the seal head from the drain hole in the tank. (See Figure 11)

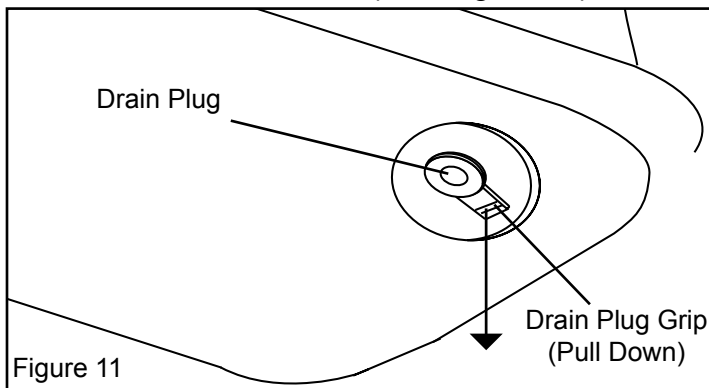

3. Using a small amount of kerosene, rinse and swirl the kerosene inside of the fuel tank, empty the tank fully.
4. To replace the drain plug; push the drain head fully into the drain hole and secure by pushing the seal cap fully into the head hole. (See Figure 12)

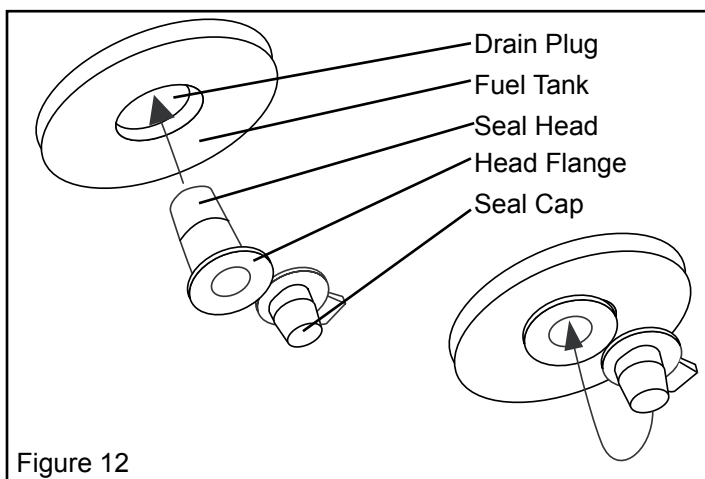

**IMPORTANT: Never store leftover kerosene between seasons, using old fuel can damage heater.**

### Service:

**▲ WARNING** Never service heater while it is plugged in or hot!

DO NOT TAMPER WITH THE UNIT. HAVE A COMPETENT SERVICEMAN MAKE ANY NECESSARY ADJUSTMENT OR REPAIRS.

Use only original equipment parts. The use of alternate or third party components can cause unsafe operating conditions and will void your warranty.

**i TIP: To order OEM parts call (800)-641-6996**

We suggest following a maintenance schedule as follows:

#### **FUEL / FUEL TANK:**

Flush tank every 200 hours of operation or as needed.

**i TIP: Follow the long term storage instructions to flush the tank.**

DO NOT flush with water, use fresh 1-K kerosene only.

#### **AIR FILTERS:**

The air intake filter should be replaced or washed with soap and water and dried thoroughly every 500 hours of operation or less depending on conditions.

The output and lint filters should be replaced every 500 hours of operation or less depending on conditions.

**NOTE: Use of diesel fuel may require additional maintenance**

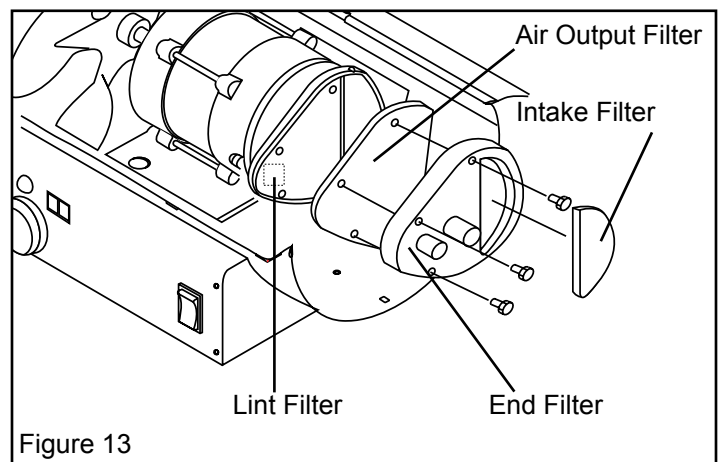

## Maintenance

### Service (Continued):

#### FAN BLADES:

Blades should be cleaned at least once per heating season, depending on conditions. Remove all accumulated dust and dirt with a damp cloth, taking care not to bend any of the fan blades. Be sure the blades are dry before re-starting the heater. For fan assembly removal see Figure 14.

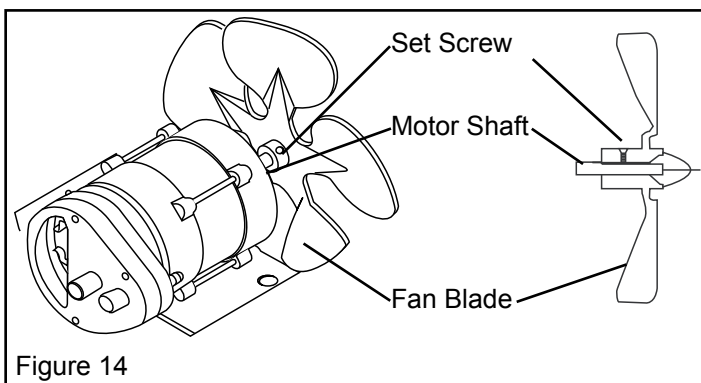

Figure 14

#### FUEL FILTER:

The fuel filter should be cleaned at least twice per heating season. Clean the filter by rinsing it in clean 1-K Kerosene. Contaminated fuel could make cleaning the fuel filter necessary immediately.

**NOTE:** To remove the filter from models 45 / 70T-KFA turn filter 90° clockwise. To remove the filter from models 125T / 175T / 215T-KFA turn filter 90° counter-clockwise. See Figure 15.

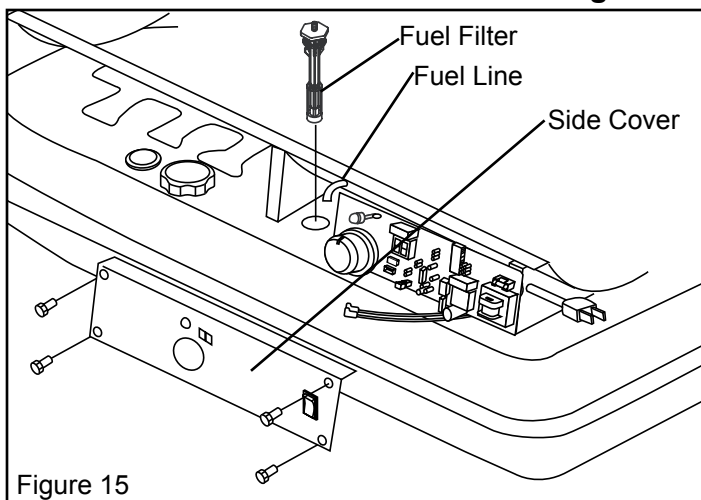

Figure 15

#### SPARK PLUG:

Clean and re-gap every 600 hours of operation, or replace as needed. After removing the spark plug, clean the terminals with a wire brush. Re-gap the terminals to 0.140" (3.5mm) See Figure 16.

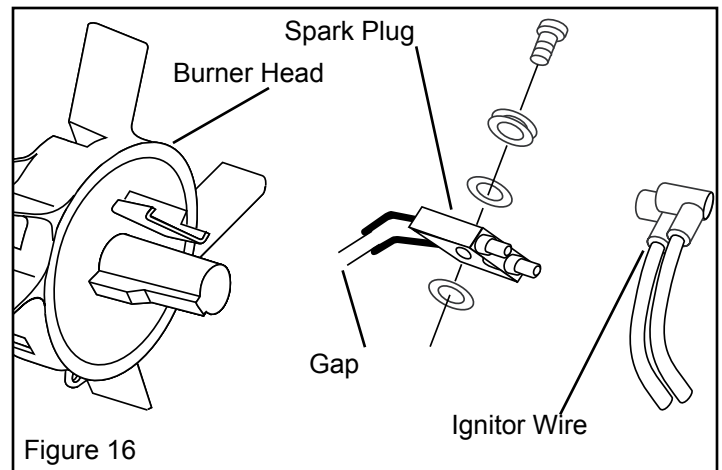

Figure 16

#### PHOTOCELL:

The photocell should be cleaned using a cotton swab dipped in alcohol or water at least once per heating season, or more depending on conditions. See Figure 17.

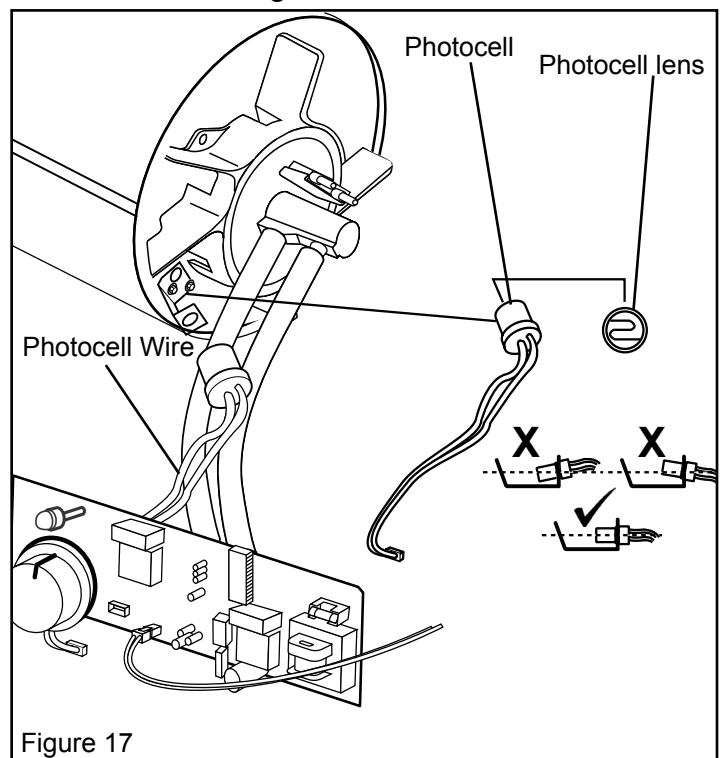

Figure 17

**Maintenance**

**PUMP PRESSURE:**

While heater is operating, turn adjusting screw clockwise to increase, counter-clockwise to decrease pressure. Correct pump pressure is as follows:

Model Number	Pump Pressure
HS-45-KFA	3.0 PSI
HS-70T-KFA	4.0 PSI
HS-125T-KFA	5.0 PSI
HS-175T-KFA	7.5 PSI
HS-215T-KFA	9.0 PSI

Tolerance  $\pm$  10%

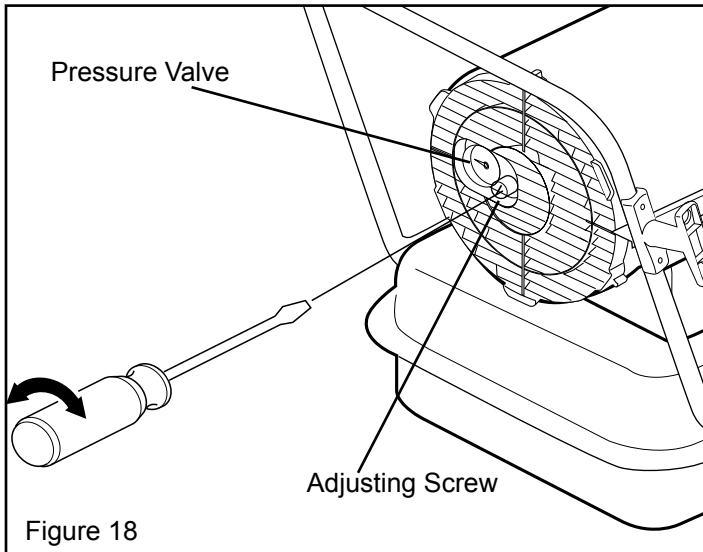

Figure 18

**NOZZLES:**

Nozzles should be cleaned or replaced at least once per heating season. Contaminated fuel could make this necessary immediately. To clean dirt from nozzle, blow compressed air through nozzle front. It may be necessary to soak the nozzle in 1-K kerosene to loosen any dirt particles.

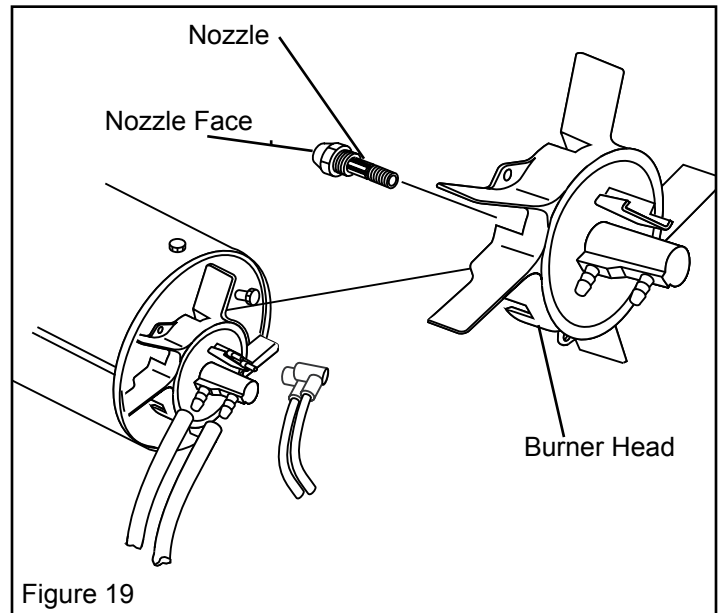

Figure 19

**Wiring Diagram**

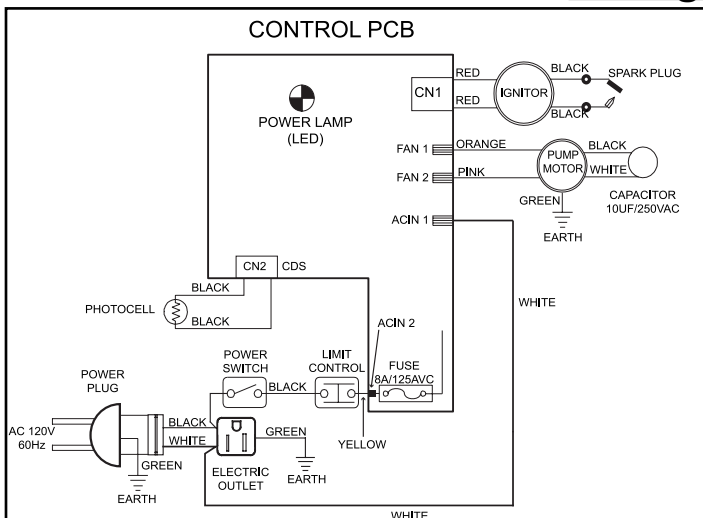

Figure 20: 45-KFA

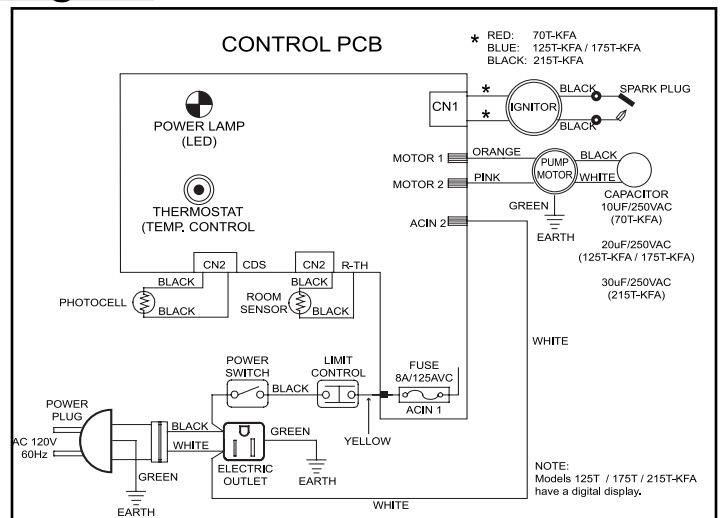

Figure 21: 70T-KFA / 125T-KFA / 175T-KFA / 215T-KFA

## Troubleshooting Guide

### Locating Your Serial Number:

Your serial number can be found on a white label on the right side cover of your heater. It will begin with 2 digits, the letter "H" followed by 6 digits. For Example: 13H123456. Have your Serial Number ready before calling customer service at 800-641-6996.

Problem	Possible Cause	Solution
Heater Ignites, but main PCB shuts off after a short period of time. Lamp flickers and LED display shows "E1".	<ol style="list-style-type: none"> <li>1. Incorrect pump pressure.</li> <li>2. Dirty input, output or lint filter.</li> <li>3. Dirty fuel filter.</li> <li>4. Nozzle is dirty.</li> <li>5. Photocell lens is dirty.</li> <li>6. Photocell not installed properly.</li> <li>7. Photocell is defective.</li> <li>8. Improper electrical connection between main PCB and photocell.</li> </ol>	<ol style="list-style-type: none"> <li>1. Adjust pump pressure.</li> <li>2. Clean / replace air or lint filter.</li> <li>3. Clean / replace fuel filter.</li> <li>4. Clean / replace Nozzle.</li> <li>5. Clean / replace photocell.</li> <li>6. Adjust photocell position</li> <li>7. Replace photocell</li> <li>8. Check wiring connections (see wiring diagrams on page 11).</li> </ol>
Heater will not operate or motor runs for a short time. Lamp flickers and LED display shows "E1".	<ol style="list-style-type: none"> <li>1. No kerosene in the fuel tank.</li> <li>2. Incorrect pump pressure.</li> <li>3. Corroded spark plug or incorrect plug gap.</li> <li>4. Dirty fuel filter.</li> <li>5. Dirty nozzle.</li> <li>6. Moisture in fuel tank.</li> <li>7. Improper electrical connection between transformer and circuit board.</li> <li>8. Ignitor wire not connected to spark plug.</li> <li>9. Defective ignitor.</li> </ol>	<ol style="list-style-type: none"> <li>1. Fill tank with fresh kerosene.</li> <li>2. Adjust pump pressure.</li> <li>3. Clean / replace spark plug.</li> <li>4. Clean / replace fuel filter.</li> <li>5. Clean / replace nozzle.</li> <li>6. Rinse fuel tank with clean, fresh kerosene.</li> <li>7. Inspect all electrical connections. (See wiring diagrams on page 11.)</li> <li>8. Re-attach ignitor wire to spark plug.</li> <li>9. Replace ignitor.</li> </ol>
Fan does not operate when heater is plugged in and power switch is in the "ON" position. The lamp is flickering or and LED display shows "E1" or "E2".	<ol style="list-style-type: none"> <li>1. Thermostat is set too low (does not apply to 45-KFA model).</li> <li>2. Broken electrical connection between main PCB and motor.</li> </ol>	<ol style="list-style-type: none"> <li>1. Rotate thermostat to a higher setting</li> <li>2. Inspect all electrical connections (see wiring diagrams on page 11).</li> </ol>
Lamp is flickering and LED display shows "E3".	<ol style="list-style-type: none"> <li>1. Thermostat switch has failed.</li> </ol>	<ol style="list-style-type: none"> <li>1. Replace thermostat switch (see Wiring diagrams on page 11).</li> </ol>
Poor combustion and / or excess soot production.	<ol style="list-style-type: none"> <li>1. Dirty input, output or lint filter.</li> <li>2. Dirty fuel filter.</li> <li>3. Poor quality of fuel.</li> <li>4. PSI is too high or too low.</li> </ol>	<ol style="list-style-type: none"> <li>1. Clean / replace air or lint filter.</li> <li>2. Clean / replace fuel filter.</li> <li>3. Flush fuel tank and refuel heater.</li> <li>4. Use proper pressure.</li> </ol>
Heater does not turn on and the lamp is not lit.	<ol style="list-style-type: none"> <li>1. Temperature limit sensor has overheated.</li> <li>2. No electrical power.</li> <li>3. Fuse is blown.</li> <li>4. Improper electrical connection between temperature limit sensor and circuit board.</li> </ol>	<ol style="list-style-type: none"> <li>1. Push power switch to "OFF" and allow heater to cool for 10 minutes. Restart heater.</li> <li>2. Check power cords for proper connection and test the power supply.</li> <li>3. Check / replace the fuse.</li> <li>4. Inspect all electrical connections (see wiring diagrams on page 11).</li> </ol>



**Exploded View**

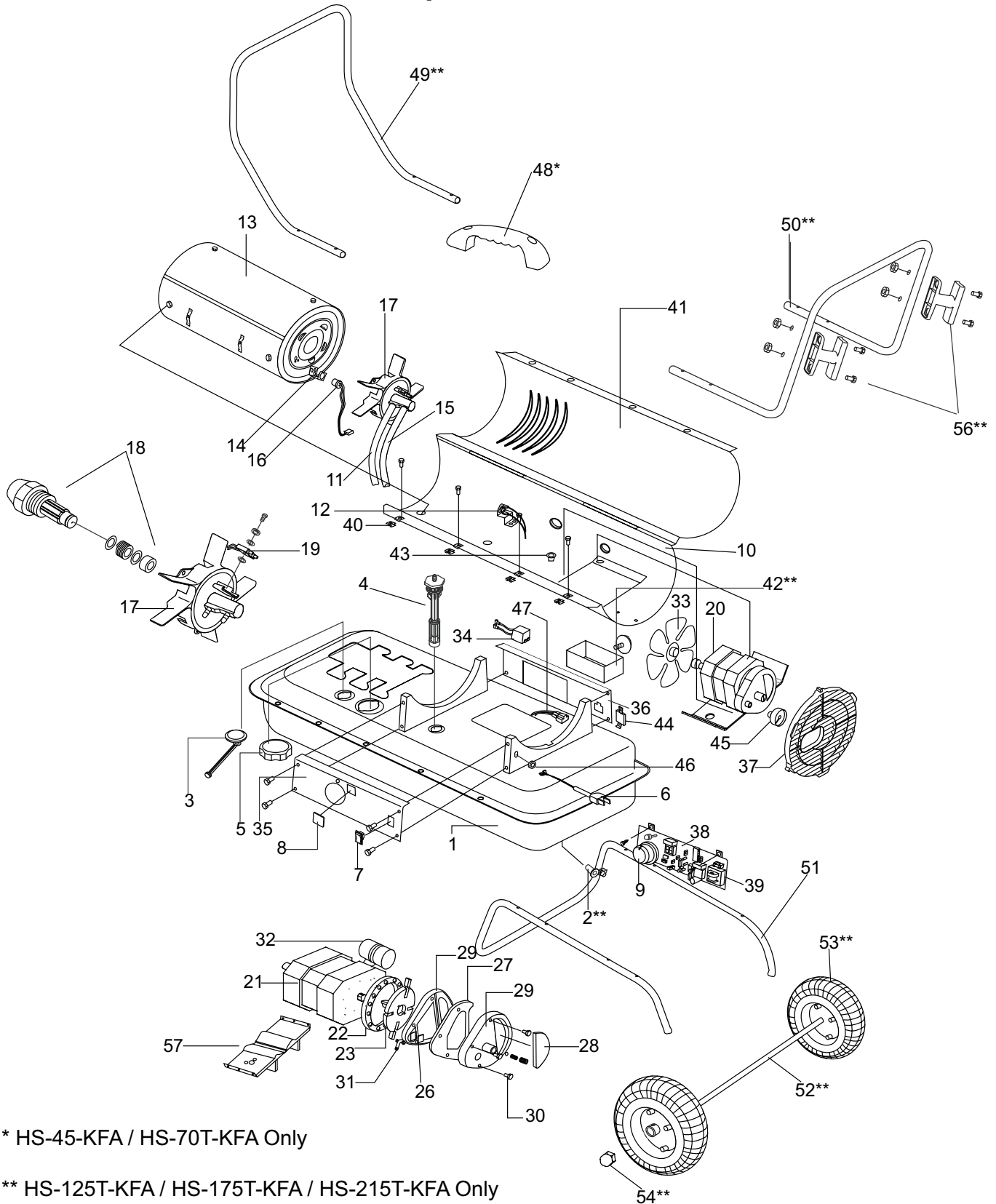

\* HS-45-KFA / HS-70T-KFA Only

\*\* HS-125T-KFA / HS-175T-KFA / HS-215T-KFA Only

## Parts List

Item No.	Description	Part Number for Models:				
		HS-45-KFA	HS-70T-KFA	HS-125T-KFA	HS-175T-KFA	HS-215T-KFA
1	Fuel Tank Assembly	70-002-0100	70-002-0100	70-002-0200	70-002-0300	70-002-0300
2	Drain Plug	—	—	70-002-0105	70-002-0105	70-002-0105
3	Fuel Gauge Assembly	70-007-0110	70-007-0115	70-007-0210	70-007-0210	70-007-0215
4	Fuel Filter Assembly	70-003-0100	70-003-0100	70-003-0200	70-003-0200	70-003-0200
5	Fuel Cap	70-006-0100	70-006-0100	70-006-0100	70-006-0100	70-006-0100
6	Power Cord	70-034-0100	70-034-0100	70-034-0200	70-034-0200	70-034-0200
7	Power Switch	70-038-0100	70-038-0100	70-038-0100	70-038-0100	70-038-0100
8	Window Display	—	—	70-040-0100	70-040-0100	70-040-0100
9	Thermostat Control Knob	—	70-031-0100	70-031-0100	70-031-0100	70-031-0100
10	Lower Shell	—	—	—	—	—
11	Air Line	70-035-0100	70-035-0200	70-035-0300	70-035-0400	70-035-0500
12	Thermostat Limit Control	70-019-0100	70-019-0100	70-019-0100	70-019-0100	70-019-0200
13	Combustion Chamber Assembly	70-011-0100	70-011-0200	70-011-0300	70-011-0400	70-011-0500
14	Photocell Bracket	70-010-0101	70-010-0101	70-010-0101	70-010-0101	70-010-0101
15	Fuel Line	70-036-0100	70-036-0200	70-036-0300	70-036-0400	70-036-0500
16	Photocell Assembly	70-016-0100	70-016-0100	70-016-0100	70-016-0100	70-016-0100
17	Burner Head Assembly	70-014-0101	70-014-0101	70-014-0301	70-014-0401	70-014-0401
18	Nozzle Kit	70-015-0100	70-015-0200	70-015-0300	70-015-0400	70-015-0500
19	Spark Plug Kit	70-052-0100	70-052-0100	70-052-0200	70-052-0200	70-052-0200
20	Motor and Pump Assembly	70-020-0550	70-020-0550	70-020-0555	70-020-0560	70-020-0565
21	Motor	70-021-0500	70-021-0500	70-021-0510	70-021-0520	70-021-0520
22	Pump Body	70-020-0101	70-020-0101	70-020-0101	70-020-0101	70-020-0401
23	Rotor Kit	70-022-0100	70-022-0100	70-022-0100	70-022-0100	70-022-0200
24	End Pump Cover	70-020-0102	70-020-0102	70-020-0102	70-020-0102	70-020-0102
25	Filter Kit	70-054-0100	70-054-0100	70-054-0100	70-054-0100	70-054-0100
26	Lint Filter	70-054-0102	70-054-0102	70-054-0102	70-054-0102	70-054-0102
27	Output Filter	70-054-0100	70-054-0100	70-054-0100	70-054-0100	70-054-0100
28	Intake Filter	70-054-0101	70-054-0101	70-054-0101	70-054-0101	70-054-0101
29	End Filter Cover	70-020-0103	70-020-0103	70-020-0103	70-020-0103	70-020-0103
30	Plug/Pump Adjustment Kit	70-055-0100	70-055-0100	70-055-0100	70-055-0100	70-055-0100
31	Nipple	70-014-0104	70-014-0104	70-014-0104	70-014-0104	70-014-0104
32	Capacitor	70-020-0107	70-020-0107	70-020-0201	70-020-0201	70-020-0201
33	Fan Assembly	70-024-0100	70-024-0200	70-024-0300	70-024-0400	70-024-0400
34	Ignitor	70-037-0300	70-037-0300	70-037-0300	70-037-0300	70-037-0300
35	Right Side Cover	—	—	—	—	—
36	Left Side Cover	—	—	—	—	—
37	Fan Guard	70-016-0700	70-016-0700	70-016-0200	70-016-0200	70-016-0220
38	Main PCB Assembly	70-027-0100	70-027-0200	70-027-0300	70-027-0300	70-027-0300
39	Fuse	70-027-0101	70-027-0101	70-027-0101	70-027-0101	70-027-0101
40	Clip Nut	70-001-0105	70-001-0105	70-001-0105	70-001-0105	70-001-0105
41	Upper Shell	—	—	—	—	—
42	Storage Box	—	—	70-053-0100	70-053-0100	70-053-0100
43	Bushing Grommet	70-017-0100	70-017-0100	70-017-0100	70-017-0100	70-017-0100
44	Socket Cover	70-030-0100	70-030-0100	70-030-0100	70-030-0100	70-030-0100
45	Air Pressure Gauge	70-025-0100	70-025-0100	70-025-0100	70-025-0100	70-025-0100
46	Cord Bushing	70-033-0100	70-033-0100	70-033-0200	70-033-0200	70-033-0200
47	Electric Outlet	70-029-0100	70-029-0100	70-029-0100	70-029-0100	70-029-0100
48	Handle	70-001-0103	70-001-0103	—	—	—
49	Front Handle	—	—	70-042-0100	70-042-0200	70-042-0200
50	Rear Handle	—	—	70-043-0105	70-043-0205	70-043-0205
51	Wheel Support Frame	—	—	70-041-0101	70-041-0201	70-041-0201
52	Wheel Axle	—	—	70-041-0115	70-041-0205	70-041-0205
53	Wheel	—	—	70-041-0415	70-041-0415	70-041-0415
54	Wheel Nut	—	—	70-041-0550	70-041-0550	70-041-0550
55	Hardware Kit	70-056-0100	70-056-0100	70-056-0210	70-056-0210	70-056-0210
56	Cord Wrap	70-032-0100	70-032-0100	70-032-0200	70-032-0200	70-032-0200
57	Motor Supporter	70-020-0600	70-020-0600	70-020-0610	70-020-0610	70-020-0610

## LIMITED WARRANTY

**Pinnacle Products International, Inc.** warrants this heater to the original retail purchaser only, to be free from defects in material and workmanship for a period of one (1) year from the date of initial purchase. This product must be properly installed, maintained and operated in accordance with the instructions provided.

**Pinnacle Products International, Inc.** requires reasonable proof of your date of purchase from an authorized retailer or distributor. Therefore, you should keep your sales slip, invoice or cancelled check from the original purchase. This Limited Warranty shall be limited to the repair or replacement of parts, which prove defective under normal use and service within the warranty period, and which **Pinnacle Products International, Inc.** shall determine at its reasonable discretion.

This warranty does not apply to products purchased for rental use.

This Limited Warranty does not cover any failures or operating difficulties due to normal wear and tear, accident, abuse, misuse, alteration, misapplication, improper installation or improper maintenance and service by you or any third part. Failure to perform normal and routine maintenance on the heater, shipping damage, damage related to insects, birds or animals of any kind, and damage due to weather conditions are also not covered. In addition, the Limited Warranty does not cover damage to the finish, such as scratches, dents, discoloration, rust or other weather damage, after purchase.

All transportation costs for the return of damaged product or parts will be the responsibility of the purchaser. Upon receipt of damaged item, **Pinnacle Products International, Inc.** will examine the item and determine if defective. **Pinnacle Products International, Inc.** will repair or replace and return the item, freight pre-paid.

If **Pinnacle Products International, Inc.** finds the item to be in normal operating condition, or not defective the item will be returned freight collect. This Limited Warranty is in lieu of all other express warranties. **Pinnacle Products International, Inc.** disclaims all warranties for products that are purchased from sellers other than authorized dealers or distributors.

AFTER THE PERIOD OF THE ONE (1) YEAR EXPRESS WARRANTY EXPIRES, **Pinnacle Products International, Inc.** DISCLAIMS ANY AND ALL IMPLIED WARRANTIES, INCLUDING WITHOUT LIMITATION THE IMPLIED WARRANTIES OF MERCHANTABILITY AND FITNESS FOR A PARTICULAR APPLICATION. FURTHER, **Pinnacle Products International, Inc.** SHALL HAVE NO LIABILITY WHATSOEVER TO PURCHASER OR ANY THIRD PARTY FROM ANY SPECIAL, INDIRECT, PUNITIVE INCIDENTAL, OR CONSEQUENTIAL DAMAGES. **Pinnacle Products International, Inc.** assumes no responsibility for any defects caused by third parties. This Limited Warranty gives the purchaser specific legal rights; a purchaser may have other rights depending upon where he or she lives. Some states do not allow the exclusion or limitation of special, incidental or consequential damages, or limitations on how long a warranty lasts, so the above exclusion and limitations may not apply to you.

**Pinnacle Products International, Inc.** does not authorize any person or company to assume for it any other obligation or liability in connection with the sale, installation, use, removal, return or replacement of its equipment, and no such representations are binding on **Pinnacle Products International, Inc.**

Always be sure to specify the model number and serial number when making any claim with **Pinnacle Products International, Inc.** For your convenience, use the space provided below to list this information.

Register Your Product Online at: [http://www.heat-stream.com/Product\\_Registration.php](http://www.heat-stream.com/Product_Registration.php)

### Locating Your Serial Number:

Your serial number can be found on a white label on the right side cover of your heater. It will begin with 2 digits, the letter "H" followed by 6 digits. For Example: 13H123456. Have your Serial Number ready before calling customer service at 800-641-6996.

Model #: \_\_\_\_\_

Serial #: \_\_\_\_\_

Date of Purchase: \_\_\_\_\_

