

HEAT STREAM

User's Manual and Operating Instructions

**Model Numbers: HS-40-GFA, HS-60V-GFA,
HS-125V-GFA, HS-150V-GFA**



Consumer: Please Read These Instructions And Keep For Your Reference

▲ GENERAL HAZARD WARNING

FAILURE TO COMPLY WITH THE PRECAUTIONS AND INSTRUCTIONS PROVIDED WITH THIS HEATER, CAN RESULT IN DEATH, SERIOUS BODILY INJURY AND PROPERTY LOSS OR DAMAGE FROM HAZARDS OF FIRE, EXPLOSION, BURN, ASPHYXIATION, CARBON MONOXIDE POISONING AND / OR ELECTRIC SHOCK.

ONLY PERSONS WHO CAN UNDERSTAND AND FOLLOW THE INSTRUCTIONS SHOULD USE OR SERVICE THIS HEATER.

IF YOU NEED ASSISTANCE OR HEATER INFORMATION SUCH AS AN INSTRUCTIONS MANUAL, LABEL, ETC. CONTACT THE MANUFACTURER.

▲ WARNING **Carbon Monoxide Hazard** This heater produces carbon monoxide, which has no odor. Burning the heater in an enclosed space can kill you. Never use the heater in enclosed spaces such as a tent, a camper, any vehicle or recreational vehicle (RV), enclosed shelter, or any other enclosed areas.

▲ DANGER **Not for use in residential living areas or in non-adequately ventilated enclosed spaces. Never bring or store a propane cylinder indoors.**

© Pinnacle Products International, Inc.

668 Stony Hill Road #302 Yardley, PA 19067 USA Toll Free: (800) 641-6996
Fax: (215) 891-8461 • Web: www.pinnacleint.com • Email: info@pinnacleint.com

221000162-12

Table of Contents

Safety Information..... 2-3 Unpacking3 Features 4 Propane Information 4-5 Pre-Lighting Instructions 5 Ventilation 6 Lighting Instructions 6	Long Term Storage / Maintenance 6 Wiring Diagrams 7 Exploded View 8 Replacement Parts 9 Troubleshooting 10 Warranty 11
---	---

Safety Information

▲WARNING FIRE, BURN, INHALATION, AND EXPLOSION HAZARD. KEEP SOLID COMBUSTIBLES, SUCH AS BUILDING MATERIALS, PAPER OR CARDBOARD, A SAFE DISTANCE AWAY FROM THE HEATER AS RECOMMENDED BY THESE INSTRUCTIONS. NEVER USE THE HEATER IN SPACES WHICH DO OR MAY CONTAIN VOLATILE OR AIRBORNE COMBUSTIBLES, OR PRODUCTS SUCH AS GASOLINE, SOLVENTS, PAINT THINNERS, DUST PARTICLES OR UNKNOWN CHEMICALS.

▲WARNING NOT FOR HOME OR RECREATIONAL USE.

▲WARNING Do not operate this heater until you have read, and thoroughly understand these safety and operating instruction.

▲WARNING **California Residents:** Combustion by-products produced when using this product contain carbon monoxide, a chemical known to the state of California to cause cancer and birth defects (or other reproductive harm).

▲DANGER *Indicates an imminently hazardous situation which, if not avoided, WILL result in death or serious injury.*

▲WARNING *Indicates a potentially hazardous situation which, if not avoided, COULD result in death or serious injury.*

▲CAUTION *Indicates a potentially hazardous situation which, if not avoided, MAY result in minor or moderate injury.*

This heater is designed and approved for use as a construction heater in accordance with Standard ANSI Z83.7-2011/CSA 2.14-2011. CHECK WITH YOUR LOCAL FIRE SAFETY AUTHORITY IF YOU HAVE ANY QUESTIONS ABOUT APPLICATIONS. Other standards govern the use of fuel gases and heating products for specific uses. Your local authority can advise you about these.

The primary purpose of construction heaters is to provide temporary heating of buildings under construction, alteration, or repair. Properly used, the heater provides safe economical heating. Products of combustion are vented into the area being heated.

IMPORTANT: Read this User's Manual carefully and completely before attempting to operate, assemble, or service this heater. Improper use of the heater can cause serious injury or death from fire, explosion and carbon monoxide poisoning.

Every possible circumstance that may involve a hazard cannot be anticipated. The warnings in this manual and attached to the unit are therefore not all-inclusive. If a procedure, work method or operating technique not specifically recommended by Pinnacle is used, you must be sure it is safe for you and others. You should also insure that equipment will not be damaged or made unsafe by the operating or maintenance method you choose.

▲DANGER *If the information in this manual is not followed exactly, a fire or explosion may result causing property damage, personal injury or loss of life.*

- **WHAT TO DO IF THE SMELL OF GAS IS PRESENT:**
- **DO NOT** attempt to light heater.
- Extinguish any open flame.
- Shut off gas to heater.
- If odor continues, contact your local gas supplier or fire department.
- Do not touch any electric switch, do not use any
Immediately call your gas supplier from a neighbors phone. Follow the gas suppliers instructions.
- If you can not reach your gas supplier, call the fire department.
- **Service must be done by a qualified service agency or the gas supplier.**

This is an unvented portable heater. It uses air (oxygen) from the area in which it is used. Adequate combustion and ventilation air must be provided. Refer to VENTILATION on Page 5.

Safety Information (continued)

This is a direct-fired, forced-air construction heater for either indoor or outdoor use. It's intended use is primarily for the temporary heating of buildings under construction, alteration or repair. All of the products of combustion generated by this heater are forced through the heater and released into the area being heated. This heater operates at approximately 98%+ combustion efficiency, but still produces small amounts of carbon monoxide. Humans can tolerate small amounts of carbon monoxide for short periods. Carbon monoxide can build up in a heated space, and failure to provide adequate ventilation could result in poisoning or death.

You must provide the propane gas and cylinder(s). Use this heater only with a propane vapor withdrawal supply system. Refer to Chapter 5 of the Standard for Storage and Handling of Liquefied Petroleum Gas, ANSI/NFPA 58. Your local library or fire department will have this booklet.

- Children should be kept away.
- Always maintain proper clearance from combustible materials.

Minimum clearance should be:

Sides - 24" Top - 36" Front - 72"

- Do not store or use gasoline or other flammable vapors and liquids in the vicinity of this or any other appliance.
- An LP cylinder not connected for use shall not be stored in the vicinity of this or any other appliance.
- Heater must be placed on level and solid footing.
- Never place anything, including clothes or other flammable items on heater.
- Do not modify heater, or operate a heater that has been modified.
- Adequate clearance for accessibility, combustion and ventilation (air supply) must be maintained at all times when heater is operating.
- Service and repair should be performed by a qualified service person. The heater should be inspected before each use, and at least annually by a qualified person. More frequent cleaning may be required as necessary. Do not service heater while hot or operating.
- Never connect heater to an unregulated gas supply.
- This heater is equipped with a 3-prong (grounding) plug for your protection against shock hazard and should be plugged directly into a properly grounded three-prong receptacle.
- Use only the electrical/power cord specified. Electrical and

grounding connection must comply with National Electrical Code - ANSI/NFPA 70 (USA) and CSA C22.1 Canadian Electrical Code, Part 1 (Canada).

- To prevent injury, always wear gloves when handling heater. Never handle an operating or hot heater, as severe burns may result.
- Use heater in accordance with all local codes. In the absence of local codes, refer to The National Fuel Code, ANSI Z223.1.
- This heater is shipped from the factory for use with LP (propane) gas only. Do not convert to any other gas. Installation must conform to local codes, or in their absence, with the standard for the Storage and Handling of Liquefied Petroleum Gases ANSI/NFPA 58 and the Natural Gas and Propane Installation Code 149.1.
- Use only the regulator and hose assembly provided with this heater. Inspect the regulator/hose assembly prior to each use of the heater. If there is excessive abrasion or wear, or if the hose is cut, replace it with the proper assembly shown in the parts list, prior to using the heater.

▲ WARNING *The hose assembly shall be protected from traffic, building material and contact with hot surfaces both during use and while in storage.*

- Gas supply connections should be checked by using a 50/50 soap and water solution. Never use a flame to check for gas leaks.
- Locate LP cylinder at least 6 feet (10 ft. in Canada) from the heater, and do not direct heater discharge towards the LP cylinder unless it is at least 20 feet from the heater.
- The electrical connection and grounding must comply with the National Electrical Code, ANSI/NFPA 70 and CSA C22.1 Canadian Electrical Code, Part 1 (Canada) Canadian Electrical Code, Part 1. Use only a properly grounded three (3) prong receptacle.
- Do not restrict air inlet or outlet areas of the heater.

▲ WARNING *Not for use with ductwork.*

Minimum and Maximum inlet Pressure				
	40	60V	125V	150V
Min.	5 PSI			
Max.	Bottle Pressure			

Unpacking

1. Remove all packing items applied to heater for shipment. Keep plastic cover caps attached to inlet connector and hose/regulator assembly for storage.
2. Remove all items from carton.
3. Check all items for shipping damage. If heater is damaged, promptly inform dealer where you purchased the heater.

▲ CAUTION *The Propane (LP) gas pressure regulator and hose assembly supplied with the heater must be used without alteration.*

Features

- Portable, stable and fully assembled.
- Wind resistant and rain protected.
- Continuous spark ignition or piezo spark ignition.
- 100% safety shut-off system.
- Adjustable input ratings (Except HS-40-GFA).
- Adjustable Height Controller.

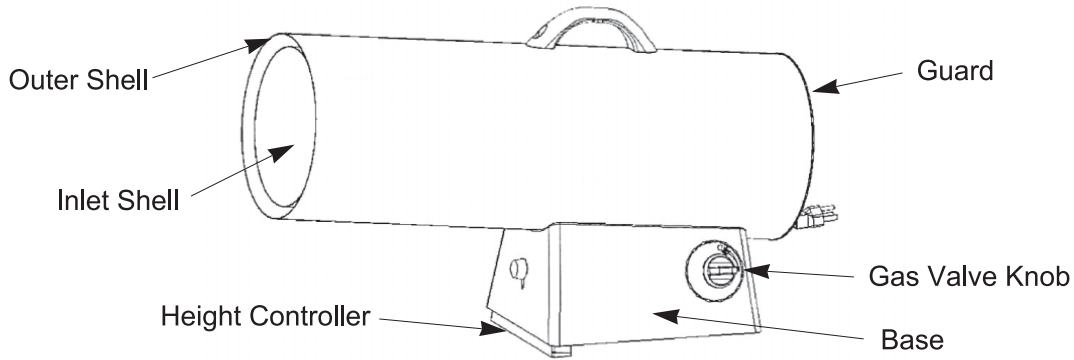

Figure 1: Product Features

Propane Supply / Information

PROPANE

You must provide the propane gas and cylinder(s). Use this heater only with a propane vapor withdrawal supply system. Refer to Chapter 5 of the Standard for Storage and Handling of Liquefied Petroleum Gas, ANSI/NFPA 58. Your local library or fire department will have this booklet.

LP Characteristics:

- Flammable, explosive under pressure, heavier than air, and pools in low areas.
- In its natural state, propane has no odor, but for your safety an odorant that smells like rotten cabbage has been added.
- Contact of propane (LP) gas with the skin can cause freeze burns.
- Heater is manufactured for use with LP gas only. DO NOT attempt to convert to any other gas. Such modifications are dangerous, and will void warranty.
- When heater is not in use, LP cylinder must be turned OFF
- Be sure that the LP cylinder is located on a level and stable surface.
- Do not use this heater in a basement or below ground level. Propane (LP) is heavier than air, and will always seek the lowest level. If you suspect a leak, shut off the valve at the LP cylinder immediately.

The Propane (LP) cylinder must also be equipped with the following:

- A collar to protect the gas valve.
- A shut-off valve terminating a LP cylinder valve outlet as

specified in the American National Standard for Compressed Gas Cylinder Valve Outlets and Inlet Connections.

- A safety relief valve having direct communications with the vapor space of the LP cylinder.
- An arrangement of vapor withdrawal.

The amount of LPG used with this heater varies. Both factors are:

1. The amount of gas in the cylinder of LPG.
2. The temperature of the LP tank and its surroundings.

Average Temp (°F)	HS-40 20 or 100 lb. cylinder	HS-60V 20 or 100 lb. cylinder	HS-125V 100 lb. cylinder	HS-150V 100 lb. cylinder
32°	1	1	2	2
20°	1	1	2	2
10°	1	1	3	3
0°	1	1	3	3
-10°	2	2	Use Larger Tank	Use Larger Tank
-20°	2	2	Use Larger Tank	Use Larger Tank

Figure 2: The table above shows the minimum number of 100 lb LP cylinders required in cold weather. Your local LP dealer will help you select the proper LP supply system.

Propane Supply / Information (Continued)

▲ CAUTION *Propane is safe to use when properly handled. Careless handling of the LP cylinder could result in a fire and/or an explosion. Therefore:*

- Always keep LP cylinder securely fastened and in an upright position.
- Avoid tipping the LP cylinder on its side when connected to a regulator, since this may cause damage to the diaphragm in the regulator.
- Handle valves with care.
- Never connect an unregulated LP cylinder to a construction heater.
- Do not subject LP cylinder to excessive heat.

- Tightly close the gas shutoff valve on the LP cylinder after each use.
- All fittings must be protected when disconnected from the LP cylinder.
- Never store an LP cylinder inside a building or in the vicinity of any gas burning appliance.

▲ CAUTION *The disconnected tank must never be stored in a building, garage or any other enclosed area.*

- Do not restrict inlet or outlet of heater. Heater is never to be used with ductwork.

Pre-Lighting Instructions

CONNECTING THE LP CYLINDER

ALL NEW LP CYLINDERS MUST BE PURGED BEFORE THE FIRST FILLING.

▲ WARNING *Purging and filling of LP cylinders must be performed by personnel who have been thoroughly trained in accepted LP gas industry procedures. Failure to follow these instructions may result in explosion, fire, severe personal injury or death.*

- Turn heater gas valve knob and LP cylinder valve to OFF position.
- LP cylinder valve equipped with old style fitting has LEFT-HANDED THREADS. Turn fitting CLOCKWISE to loosen. Protect this fitting when disconnected from LP cylinder.
- Have your LP cylinder filled by your local Propane gas supplier.
- Some LP cylinders have a bleed-off valve. This valve should be inspected for leaks after each filling of the LP cylinder. Turn the valve clockwise to close.

- Fasten full Propane tank and connect proper fitting to LP cylinder valve by turning COUNTERCLOCKWISE.

- With heater gas valve knob still in OFF position, turn ON LP cylinder valve and check for leaks with soap solution.

CHECKING FOR LEAKS

- To check for leaks, make up a 50/50 solution of dish soap and water. Apply this solution to all gas connections. If bubbles appear, there is a leak. If a leak is found, turn off the gas supply, and re-connect the leaking connection. If the leak persists after several tries, contact Pinnacle Customer Service at 215-891-8460.
- The installation of this heater must meet all local codes and/or gas utility requirements. In the absence of local codes, the National Fuel Code ANSI Z223.1 should be followed.
- The minimum clearances to any combustible construction materials must be maintained at all times (See Page 3).

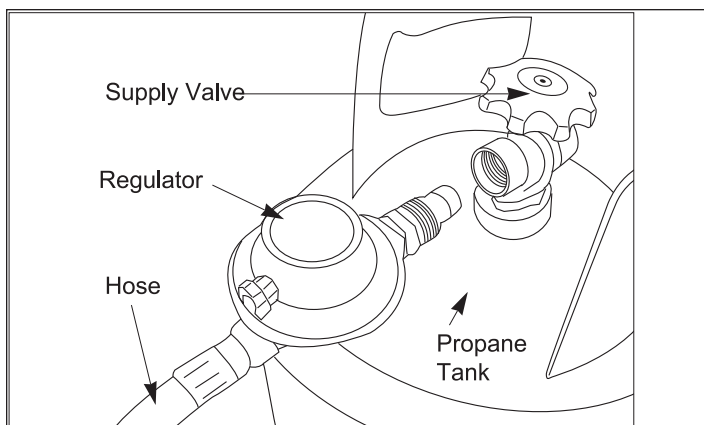

Figure 3: Connecting the Hose / Regulator to the LP Cylinder

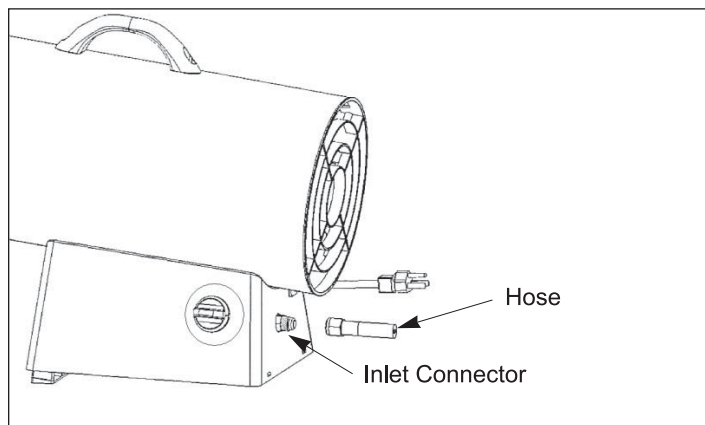

Figure 4: Connecting the Hose to Heater Inlet

Ventilation

▲ CAUTION Always provide a fresh air opening in the heated space of at least three square feet (2,800 sq. cm.) for each 100,000 BTU/Hr of heater output. For example, a HS-150V-GFA will require:

- a two-car garage door open 6 inches, or
- a single car garage open 9 inches, or
- two thirty two inch wide windows open 15 inches.

Lighting Instructions

TO START

1. Connect power cord to a properly grounded three (3) prong 120V, 60 Hz, extension cord.
Extension Cord Wire Requirements:
6 to 10 feet (1.8 to 3 meters) long, use 18 AWG conductor.
11 to 100 feet (3.4 to 30.53 meters) long, use 16 AWG conductor.
101 to 200 feet (30.8 to 61 meters) long, use 14 AWG conductor.
2. Connect heater to a proper LP cylinder.
3. Turn gas valve clockwise to OFF position.
4. Wait five (5) minutes for any gas to clear. Smell for gas; if you do not smell gas, go to Step 4.
5. Push in and turn gas control knob counterclockwise to LOW/IGN position. This will light the burner. If needed, keep pressing control knob until the burner lights and keep pressing and turning from OFF to LOW/IGN on Piezo electric spark models (HIGH/IGN on Model HS-40-GFA).
6. Keep the valve knob depressed for at least 30 seconds after lighting the burner. After 30 seconds, release valve knob.
7. If burner does not stay lit, repeat lighting procedure.
8. When burner stays lit, turn gas valve knob counterclockwise to desired setting (All models except HS-40-GFA)

SHUTDOWN INSTRUCTIONS

To shut off heater:

1. Turn gas valve knob clockwise to OFF position.
2. Turn gas supply OFF by turning LP cylinder valve clockwise to close.
3. Disconnect the power cord.

TEST FIRING THE HEATER

Test fire your construction heater following the lighting instructions applicable to the gas control system employed.

Leak test all gas connections with 50/50 soap and water solution prior to start-up. Soap bubbles indicate a gas leak. DO NOT use a match or flame to test for gas leaks.

NOTE: Heater surface temperature must be cold before initiating service, cleaning or storage.

Storage / Maintenance

Always disconnect the heater from the LP cylinder before putting the heater into storage. If for any reason the heater is to be stored indoors, the tank MUST be disconnected from the LP cylinder, and the cylinder stored outdoors in a well-ventilated area, out of the reach of children, and in accordance with the Standard for Storage and Handling of Liquefied Gases, ANSI/NFPA 58 - latest edition and Natural Gas and Propane Installation Code, CSA 149.1. The plastic valve plug or valve cover supplied with the cylinder must be re-installed on the valve to protect the fitting from damage.

▲ DANGER *Never store an LP cylinder inside of a building, or near any other gas or oil burning appliances.*

NOTE: Installation and repair of this heater should be done by a qualified service person.

Always be sure to follow proper maintenance procedures. This should include cleaning the inside the heater once a month, and checking the spark gap at least once a heating season.

Wiring Diagrams

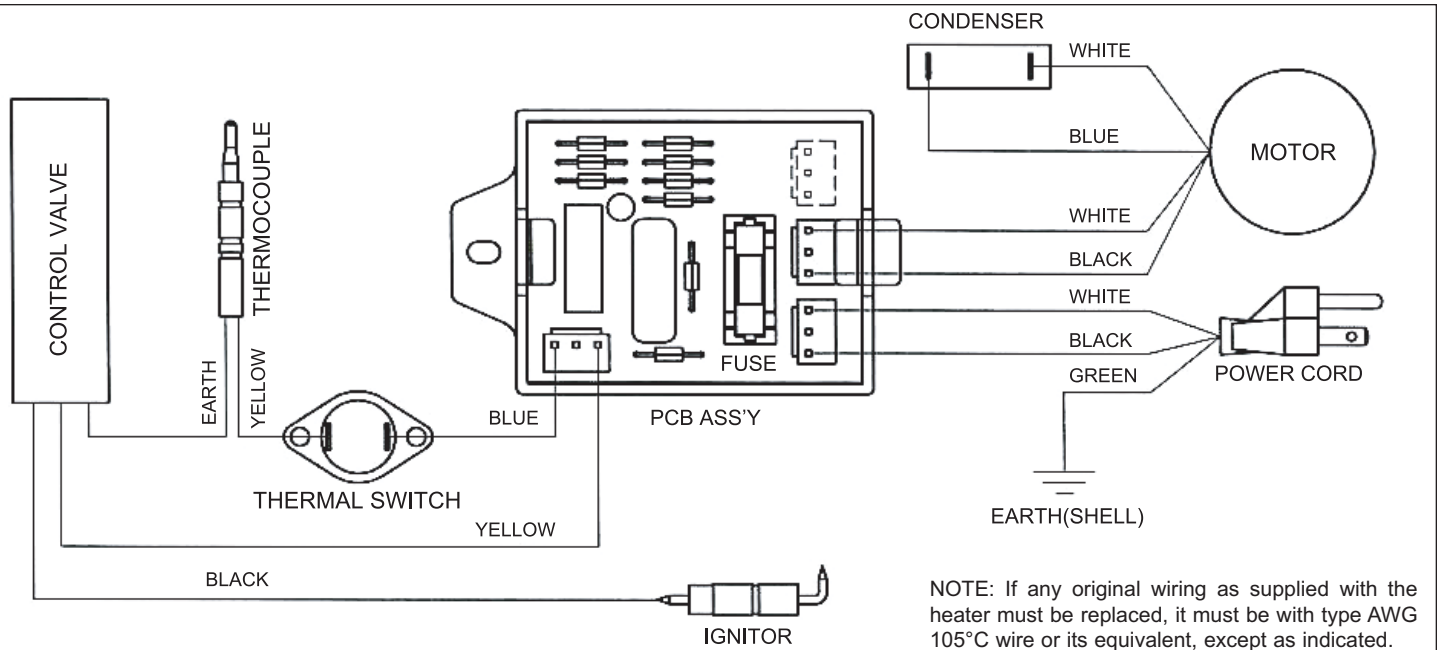

Figure 5: Wiring Diagram for Piezo/Manual Spark Models

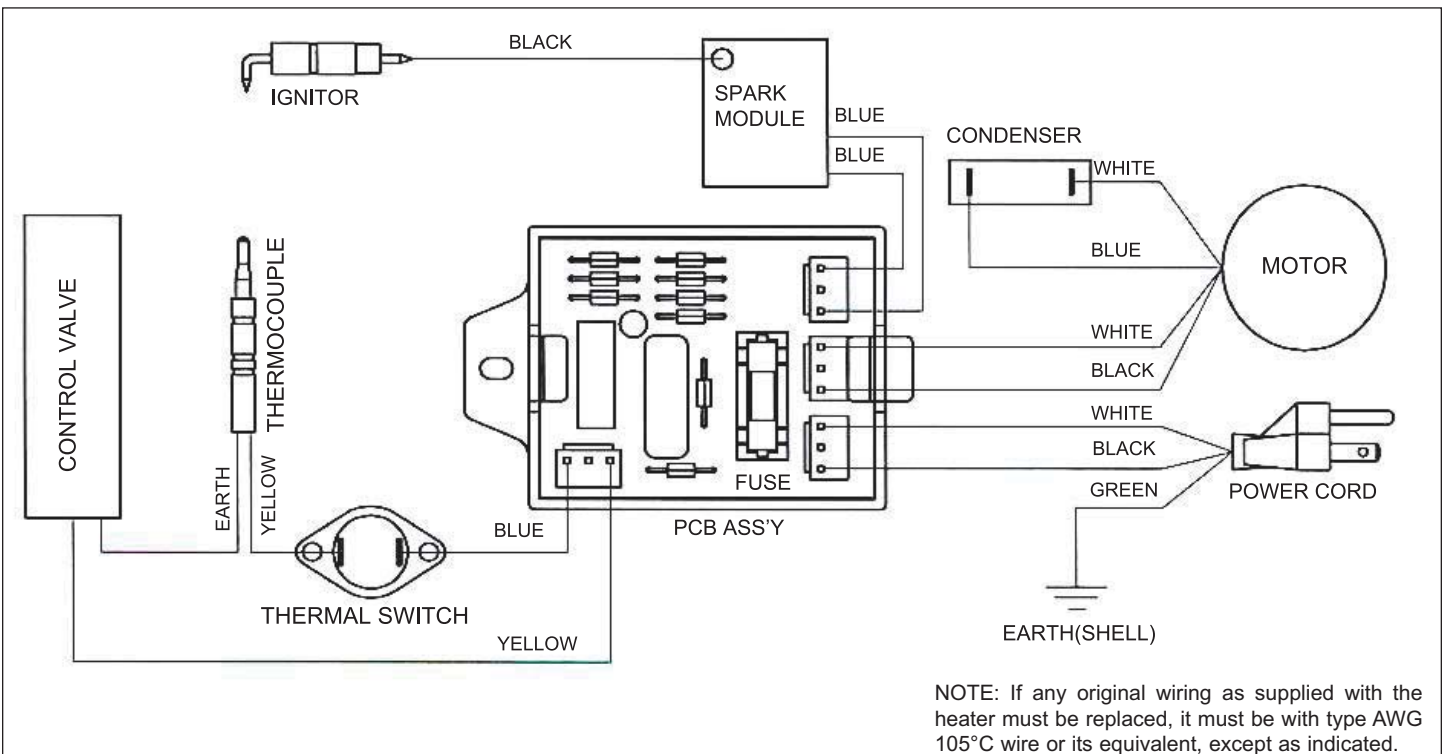

Figure 6: Wiring Diagram for Continuous Spark Models

NEVER LEAVE HEATER UNATTENDED
WHILE BURNING, CONNECTED TO A
POWER SOURCE, OR WHILE
CONNECTED TO A FUEL SOURCE

Exploded View

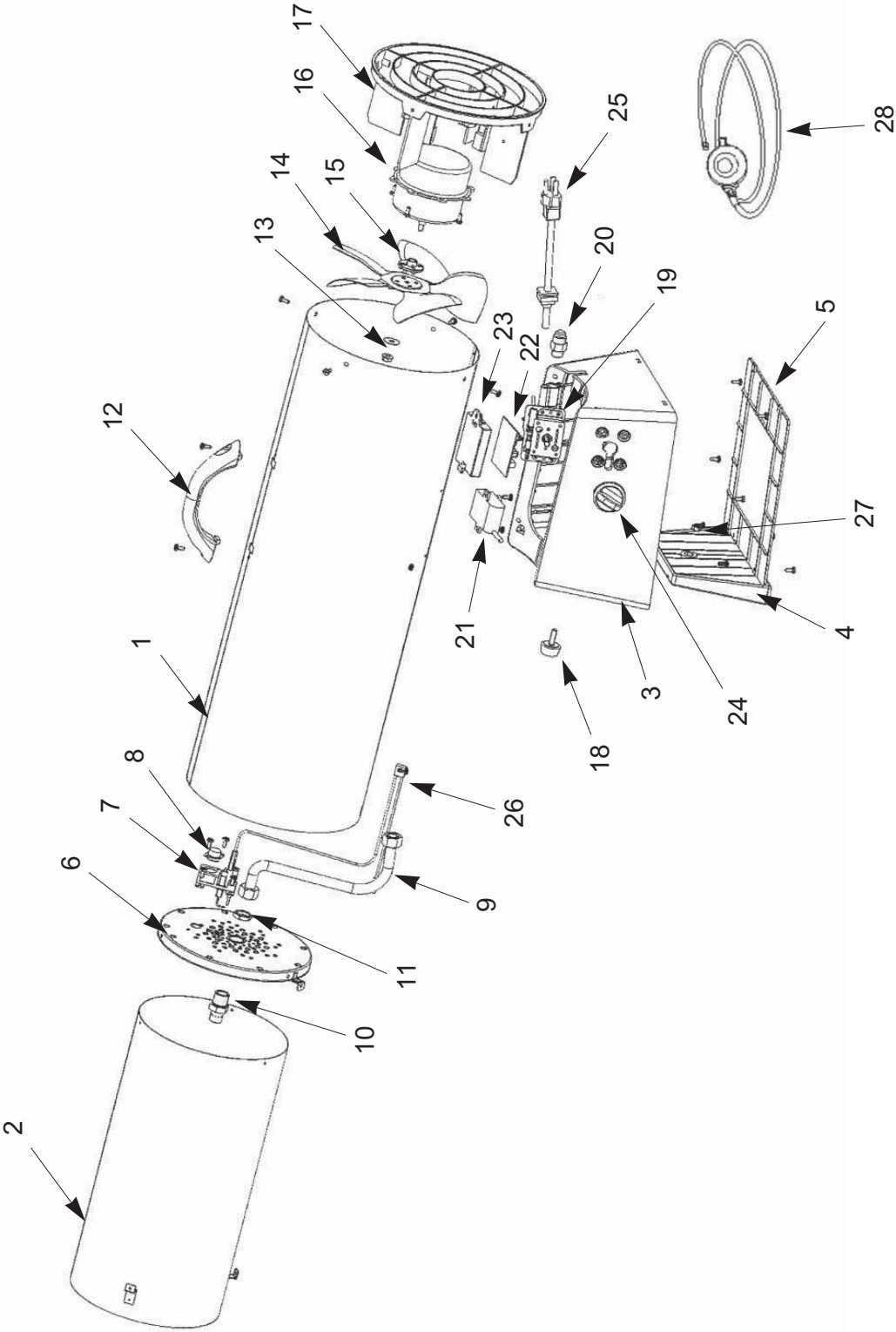

Figure 7: Exploded View for all models



**NEVER LEAVE HEATER UNATTENDED
WHILE BURNING, CONNECTED TO A
POWER SOURCE, OR WHILE
CONNECTED TO A FUEL SOURCE**

Parts Breakdown

Reference Number	Description	Part Number for Models:				Quantity
		HS-40-GFA	HS-60V-GFA	HS-125V-GFA	HS-150V-GFA	
1	Outer Shell	22-524-0050	22-524-0060	22-524-0070	22-524-0070	1
2	Inner Shell Assembly	22-524-0004	22-524-0004	22-524-0005	22-524-0005	1
3	Base	22-501-0003	22-501-0001	22-501-0002	22-501-0002	1
4	Height Controller	22-512-0005	22-512-0005	22-512-0008	22-512-0008	1
5	Base Cover	22-508-0003	22-508-0001	22-508-0002	22-508-0002	1
6	Inner Shell Cap	22-505-0006	22-505-0010	22-505-0011	22-505-0008	1
7	Multi Bracket Assembly	22-504-0002	22-504-0002	22-504-0003	22-504-0003	1
8	Thermal Switch	22-603-0001	22-603-0010	22-603-0001	22-603-0001	1
9	Tubing Assembly	22-605-0001	22-605-0001	22-605-0002	22-605-0003	1
10	Nozzle	22-081-0007	22-081-0014	22-081-0015	22-081-0004	1
11	Nozzle Nut	22-518-0001	22-518-0001	22-518-0001	22-518-0002	1
12	Handle	22-511-0004	22-511-0005	22-511-0005	22-511-0005	1
13	Flange Hex Nut	22-518-0003	22-518-0003	22-518-0003	22-518-0003	1
14	Fan	22-514-0001	22-514-0001	22-514-0002	22-514-0002	1
15	Cushion Pad	22-509-0001	22-509-0001	22-509-0001	22-509-0001	1
16	Motor Assembly	22-061-0015	22-061-0015	22-061-0016	22-061-0016	1
17	Guard	22-101-0003	22-101-0003	22-101-0004	22-101-0004	1
18	Round Bolt	22-503-0002	22-503-0002	22-503-0003	22-503-0003	1
19	Valve Assembly	22-011-0005	22-011-0017	22-011-0018	22-011-0008	1
20	Inlet Connector	22-507-0003	22-507-0003	22-507-0003	22-507-0003	1
21	Spark Module	–	22-604-0005	22-604-0005	22-604-0005	1
22	PCB Assembly	22-521-0001	22-521-0002	22-521-0002	22-521-0002	1
23	PCB Case	22-506-0001	22-506-0001	22-506-0001	22-506-0001	1
24	Valve Knob	22-516-0001	22-516-0001	22-516-0001	22-516-0001	1
25	Power Cord Assembly	22-131-0001	22-131-0001	22-131-0001	22-131-0001	1
26	Thermal Switch Cable	22-601-0001	22-601-0001	22-601-0001	22-601-0001	1
27	Hex Nut	22-518-0004	22-518-0004	22-518-0004	22-518-0004	1
28	Regulator Assembly	22-041-0004	22-041-0004	22-041-0005	22-041-0005	1

Troubleshooting

Symptom	Possible Cause(s)	Solution
Fan does not turn when electricity is connected	<ol style="list-style-type: none"> 1. No electric power to heater. 2. Blades of fan in contact with heater housing. 3. Fan blades bent. 4. Fan motor defective. 	<ol style="list-style-type: none"> 1. Check current at outlet. If voltage is correct, inspect extension and power cords for cuts, frays or breaks. 2. Check housing for damage. Be sure there are no dents in the housing obstructing the fan. 3. Straighten all fan blades. 4. Replace Motor Assembly.
Heater will not fire (ignite)	<ol style="list-style-type: none"> 1. No spark at module. 2. Incorrect spark gap. 3. Corroded electrode. 	<ol style="list-style-type: none"> 1. Inspect module wire. Re-attach, or tighten if loose. Inspect Spark module, and replace if necessary. Inspect all other electrical components. 2. Set plug gap to 0.16" (4mm). 3. Replace spark plug (Multi-Bracket Assembly).
Heater stops running by itself	<ol style="list-style-type: none"> 1. Temperature inside heater is too high, causing thermal switch to shut down operation. 2. Damaged control valve. 3. Dust or debris accumulated in heater. 	<ol style="list-style-type: none"> 1. If heater input or output is restricted, the inside temperature can become too hot. Keep the areas in front and behind heater clear of obstructions. 2. Replace control valve (Valve Assembly). 3. Clean inside of heater.



NEVER LEAVE HEATER UNATTENDED WHILE BURNING, CONNECTED TO A POWER SOURCE, OR WHILE CONNECTED TO A FUEL SOURCE

LIMITED WARRANTY

Pinnacle Products International, Inc. warrants this heater to the original retail purchaser only, to be free from defects in material and workmanship for a period of one (1) year from the date of initial purchase. This product must be properly installed, maintained and operated in accordance with the instructions provided.

Pinnacle Products International, Inc. requires reasonable proof of your date of purchase from an authorized retailer or distributor. Therefore, you should keep your sales slip, invoice, or cancelled check from the original purchase. This Limited Warranty shall be limited to the repair or replacement of parts, which prove defective under normal use and service within the warranty period, and which **Pinnacle Products International, Inc.** shall determine at its reasonable discretion.

This warranty does not apply to products purchased for rental use.

This Limited Warranty does not cover any failures or operating difficulties due to normal wear and tear, accident, abuse, misuse, alteration, misapplication, improper installation or improper maintenance and service by you or any third party. Failure to perform normal and routine maintenance on the heater, shipping damage, damage related to insects, birds, or animals of any kind, and damage due to weather conditions are also not covered. In addition, the Limited Warranty does not cover damage to the finish, such as scratches, dents, discoloration, rust or other weather damage, after purchase.

All transportation costs for the return of the damaged product or parts will be the responsibility of the purchaser. Upon receipt of damaged item, **Pinnacle Products International, Inc.** will examine the item and determine if defective. **Pinnacle Products International, Inc.** will repair or replace and return the item, freight pre-paid. If **Pinnacle Products International, Inc.** finds the item to be in normal operating condition, or not defective, the item will be returned freight collect. This Limited Warranty is in lieu of all other express warranties. **Pinnacle Products International, Inc.** disclaims all warranties for products that are purchased from sellers other than authorized retailers or distributors.

AFTER THE PERIOD OF THE ONE (1) YEAR EXPRESS WARRANTY EXPIRES, **Pinnacle Products International, Inc.** DISCLAIMS ANY AND ALL IMPLIED WARRANTIES, INCLUDING WITHOUT LIMITATION THE IMPLIED WARRANTIES OF MERCHANTABILITY AND FITNESS FOR A PARTICULAR APPLICATION. FURTHER, **Pinnacle Products International, Inc.** SHALL HAVE NO LIABILITY WHATSOEVER TO PURCHASER OR ANY THIRD PARTY FOR ANY SPECIAL, INDIRECT, PUNITIVE, INCIDENTAL, OR CONSEQUENTIAL DAMAGES. **Pinnacle Products International, Inc.** assumes no responsibility for any defects caused by third parties. This Limited Warranty gives the purchaser specific legal rights; a purchaser may have other rights depending upon where he or she lives. Some states do not allow the exclusion or limitation of special, incidental or consequential damages, or limitations on how long a warranty lasts, so the above exclusion and limitations may not apply to you.

Pinnacle Products International, Inc. does not authorize any person or company to assume for it any other obligation or liability in connection with the sale, installation, use, removal, return, or replacement of its equipment, and no such representations are binding on **Pinnacle Products International, Inc.**

Always be sure to specify model number and serial number when making any claim with **Pinnacle Products International, Inc.** For your convenience use the space provided below to list this information:

Model #: _____

Serial #: _____

Date of Purchase: _____