

OWNER'S MANUAL GC160 • GC190

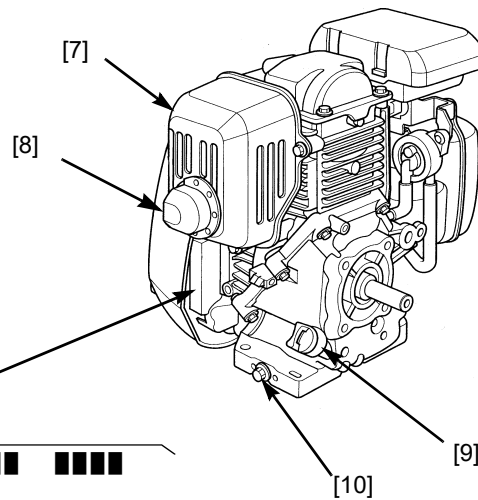

⚠ WARNING
Gasoline is highly flammable and explosive.
Turn engine off and let cool before refueling.
The engine emits toxic carbon monoxide.
Do not run in an enclosed area.
Read Owner's Manual before operation.
Honda Motor Co., Ltd.

⚠ WARNING: ⚠
The engine exhaust from this product contains chemicals known to the State of California to cause cancer, birth defects, or other reproductive harm.

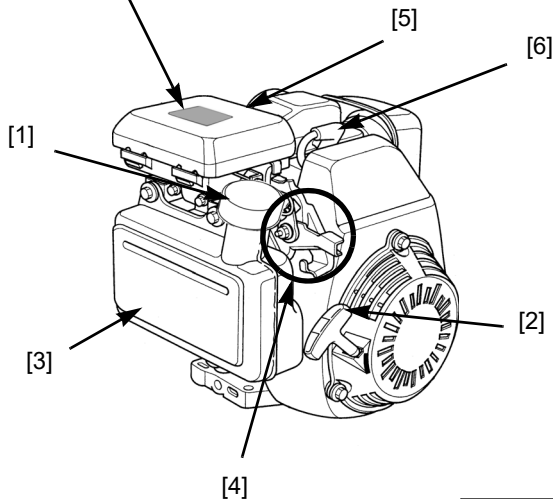

COMPONENT LOCATION

1	Fuel filler cap
2	Starter grip
3	Fuel tank
4	Control location *
5	Air cleaner
6	Spark plug

7	Muffler
8	Muffler deflector (optional)
9	Oil filler cap/dipstick
10	Oil drain bolt
11	Engine serial number and type

* The engine control area differs based on the engine type. Refer to the individual figures on [page 2](#) to determine your engine control type when reading the *Operation* section and other sections in this manual.



Type/Tipo 1

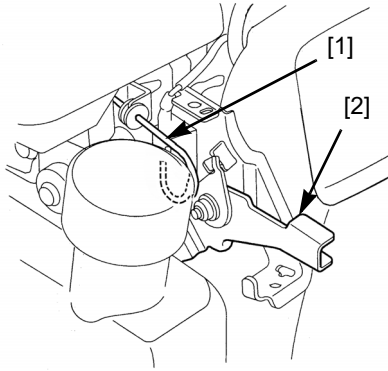

Type/Tipo 2

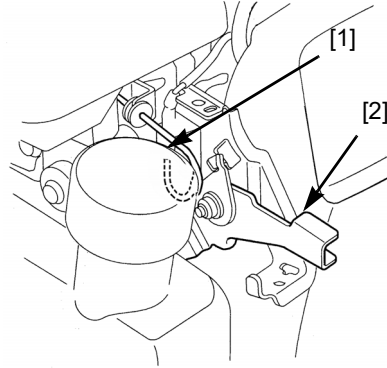

Type/Tipo 3

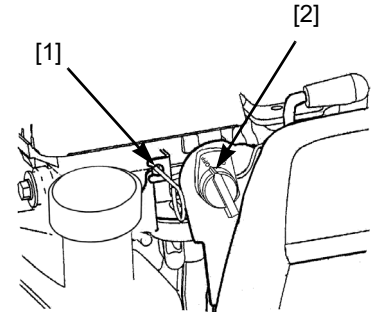

Type/ Tipo 1	Manual Choke [1], Manual Throttle (gray) [2]	Type/ Tipo 2	Manual Choke [1], Ignition Switch Lever (red) [2], Fixed Throttle	Type/ Tipo 3	Manual Choke [1], Engine Stop Switch [2], Fixed Throttle
	Étrangleur Manuel [1], Accélérateur Manuel [2]		Étrangleur Manuel [1], Levier de Commande D'allumage [2], Accélérateur Fixe		Étrangleur Manuel [1], Interrupteur d'arrêt du Moteur [2], Accélérateur Fixe
	Choke Manual [1], Acelerador Manual [2]		Choke Manual [1], Palanca del Interruptor de Encendido [2], Acelerador Fijo		Choke Manual [1], Interruptor de Parada del Motor [2], Acelerador Fijo

Figure/Figura 1

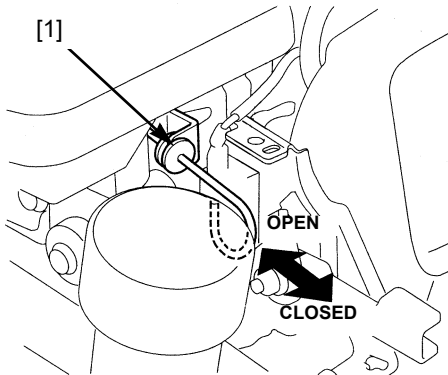

Figure/Figura 2

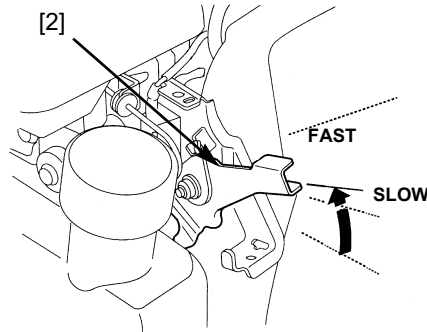

Figure/Figura 3

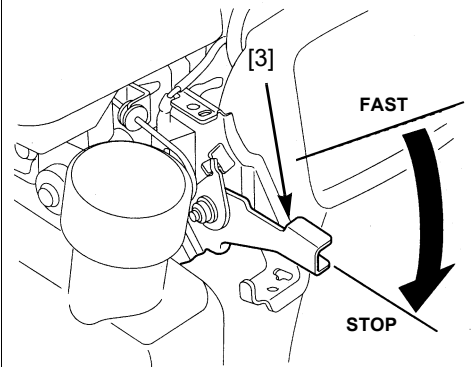

Figure/Figura 4

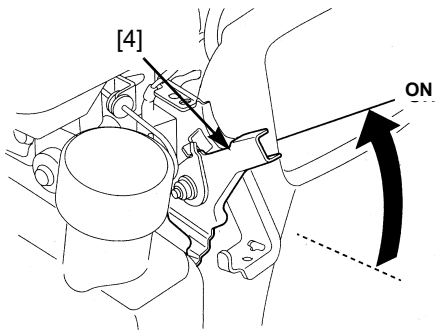

Figure/Figura 5

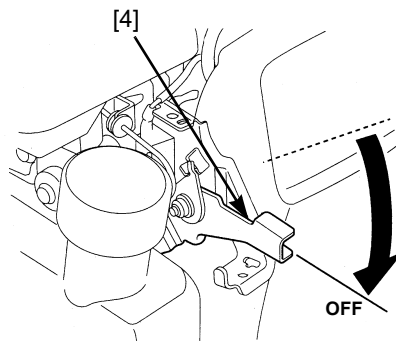

Figure/Figura 6

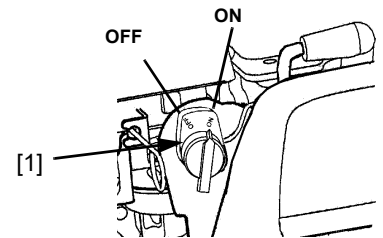

Figure/Figura 7

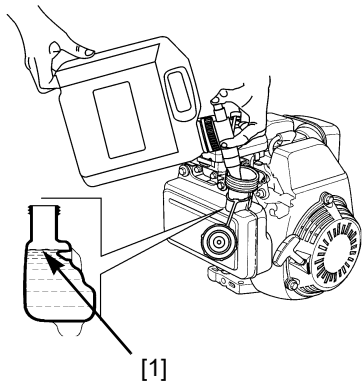

Figure/Figura 8

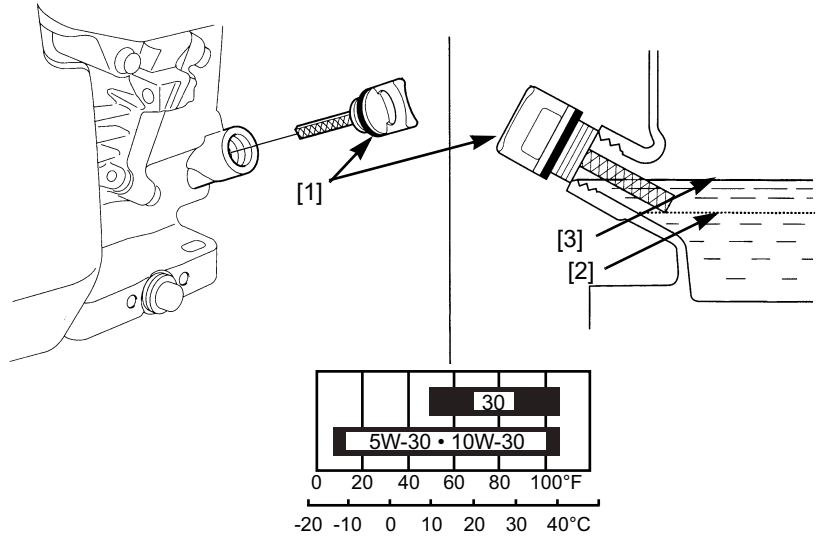

Figure/Figura 9

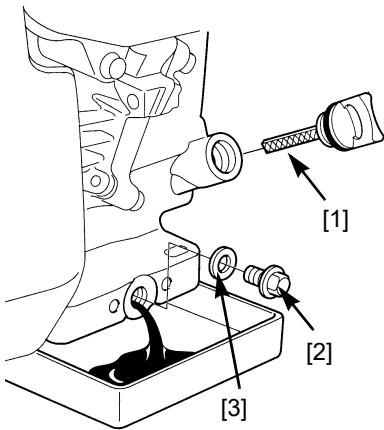

Figure/Figura 10

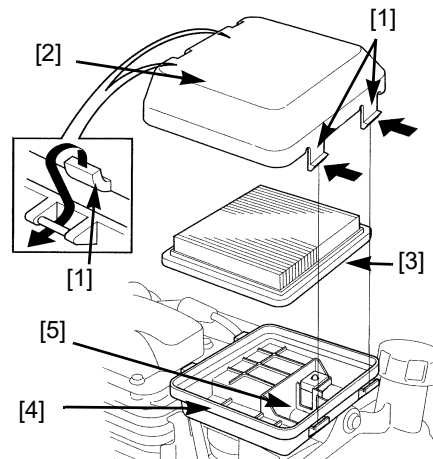

Figure/Figura 11

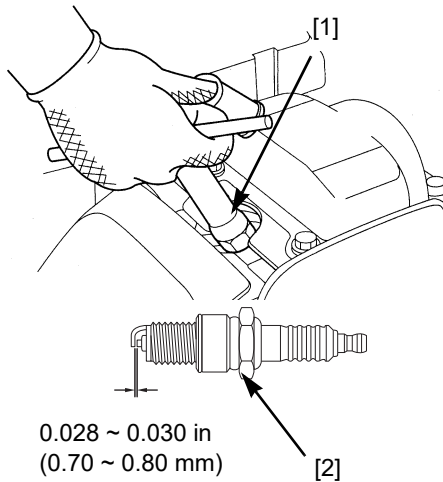

Figure/Figura 12

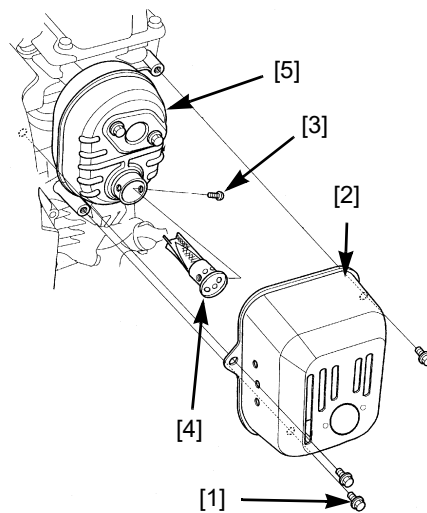

Figure/Figura 13

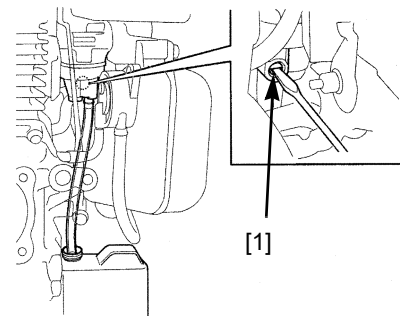

INTRODUCTION

Thank you for purchasing a Honda engine. We want to help you get the best results from your new engine and operate it safely. This manual contains information on how to do that; please read it carefully before operating the engine. If a problem should arise, or if you have any questions about your engine, consult an authorized Honda servicing dealer.

All information in this publication is based on the latest product information available at the time of printing. American Honda Motor Co., Inc. reserves the right to make changes at any time without notice and without incurring any obligation. No part of this publication may be reproduced without written permission.

This manual should be considered a permanent part of the engine and should remain with the engine if resold.

Review the instructions provided with the equipment powered by this engine for any additional information regarding engine startup, shutdown, operation, adjustments, or any special maintenance instructions.

CONTENTS

SAFETY MESSAGES	4
BEFORE OPERATION CHECKS	4
OPERATION	5
SAFE OPERATING PRECAUTIONS	5
STARTING/STOPPING THE ENGINE (ALL TYPES)	5
SERVICING YOUR ENGINE	6
MAINTENANCE SAFETY	6
MAINTENANCE SCHEDULE	6
REFUELING	6
ENGINE OIL	7
AIR CLEANER	7
SPARK PLUG	8
SPARK ARRESTER (if equipped)	8
STORING YOUR ENGINE	8
TRANSPORTING	8
TAKING CARE OF UNEXPECTED PROBLEMS	9
TECHNICAL INFORMATION	9
CONSUMER INFORMATION	11
AVOIDING FUEL-RELATED PROBLEMS	12

SAFETY MESSAGES

Your safety and the safety of others are very important. We have provided important safety messages in this manual and on the engine. Please read these messages carefully.

A safety message alerts you to potential hazards that could hurt you or others. Each safety message is preceded by a safety alert symbol  and one of three words, DANGER, WARNING, or CAUTION.

These signal words mean:

DANGER

You WILL be KILLED or SERIOUSLY HURT if you don't follow instructions.

WARNING

You CAN be KILLED or SERIOUSLY HURT if you don't follow instructions.

CAUTION

You CAN be HURT if you don't follow instructions.

Each message tells you what the hazard is, what can happen, and what you can do to avoid or reduce injury.

DAMAGE PREVENTION MESSAGES

You will also see other important messages that are preceded by the word NOTICE.

This word means:

NOTICE

Your engine, other property, or the environment can be damaged if you don't follow instructions.

The purpose of these messages is to help prevent damage to your engine, other property, or the environment.

SAFETY INFORMATION

- Understand the operation of all controls and learn how to stop the engine quickly in case of emergency. Make sure the operator receives adequate instruction before operating the equipment.
- Do not allow children to operate the engine. Keep children and pets away from the area of operation.
- Your engine's exhaust contains poisonous carbon monoxide. Do not run the engine without adequate ventilation, and never run the engine indoors.
- The engine and exhaust become very hot during operation. Keep the engine at least 3 feet (1 meter) away from buildings and other equipment during operation. Keep flammable materials away, and do not place anything on the engine while it is running.

SAFETY LABEL LOCATION

The label shown on [page 1](#) contains important safety information. Please read it carefully.

This label is considered a permanent part of your engine. So if the label comes off or becomes hard to read, contact your dealer for a replacement.

BEFORE OPERATION CHECKS

IS YOUR ENGINE READY TO GO?

For your safety, to ensure compliance with environmental regulations, and to maximize the service life of your equipment, it is very important to take a few moments before you operate the engine to check its condition. Be sure to take care of any problem you find, or have your servicing dealer correct it, before you operate the engine.

WARNING

Improperly maintaining this engine, or failing to correct a problem before operation, could cause a malfunction in which you could be seriously injured.

Always perform a pre-operation inspection before each operation, and correct any problem.

Before beginning your preoperation checks, be sure the engine is level and the throttle lever, or engine stop switch is in the STOP or OFF position.

Always check the following items before you start the engine:

1. Fuel level ([page 6](#)).
2. Oil level ([page 7](#)).

The Oil Alert[®] system (applicable engine types) will automatically stop the engine before the oil level falls below safe limits. However, to avoid the inconvenience of an unexpected shutdown, always check the engine oil level before startup.

3. Air cleaner ([page 7](#)).
4. General inspection: Check for fluid leaks and loose or damaged parts.
5. Check the equipment powered by this engine.

Review the instructions provided with the equipment powered by this engine for any precautions and procedures that should be followed before engine startup.

OPERATION

SAFE OPERATING PRECAUTIONS

Before operating the engine for the first time, please review the *SAFETY MESSAGES* and the *BEFORE OPERATION CHECKS* [page 4](#).

For your safety, do not operate the engine in an enclosed area such as a garage. Your engine's exhaust contains poisonous carbon monoxide gas that can collect rapidly in an enclosed area and cause illness or death.

⚠ WARNING

Exhaust contains poisonous carbon monoxide gas that can build up to dangerous levels in closed areas. Breathing carbon monoxide can cause unconsciousness or death.

Never run the engine in a closed or even partially closed area where people may be present.

Review the instructions provided with the equipment powered by this engine for any safety precautions that should be observed with engine startup, shutdown, or operation.

Do not operate the engine on slopes greater than 20°.

FREQUENCY OF USE

If your equipment will be used on an infrequent or intermittent basis (more than 4 weeks between usage), See "AVOIDING FUEL-RELATED PROBLEMS" on [page 12](#) for additional information regarding fuel deterioration.

STARTING/STOPPING THE ENGINE (ALL TYPES)

See the figures on the top of [page 2](#) to identify the type of control used on your equipment. Type specific starting and stopping information can be found after the general information shown below.

- **Manual choke:** Place the choke lever/rod [1] in the CHOKE position when starting a cold engine.

Move the choke lever/rod to the OFF position as soon as the engine fully warms up and runs smoothly without use of the choke, or for restarting a warm engine.
- **Engine speed:** For best engine performance, it is recommended the engine be operated with the throttle in the FAST (or high) position.
- **Starter grip:** Pull the starter grip lightly until resistance is felt, and then pull briskly.

NOTICE

Do not allow the starter grip to snap back against the engine. Return it gently to prevent damage to the starter.

OIL ALERT® SYSTEM (APPLICABLE ENGINE TYPES)

The Oil Alert system is designed to prevent engine damage caused by an insufficient amount of oil in the crankcase. Before the oil level in the crankcase can fall below a safe limit, the Oil Alert system will automatically stop the engine [the throttle lever (ignition switch lever) will remain in a run position].

If the engine stops and will not restart, check the engine oil level ([page 7](#)) before troubleshooting in other areas.

Type 1: Manual Choke, Manual Throttle

STARTING THE ENGINE

1. Move the choke rod [1] to the CLOSED position (cold engine) (see Figure 1, [page 2](#)).
2. Move the throttle lever (gray) [2] to the SLOW position, about 1/3 of the way toward the FAST position (see Figure 2, [page 2](#)).

Some engine applications use a remotely-mounted throttle control rather than the engine-mounted throttle lever shown.
3. Pull the starter grip lightly until resistance is felt; then pull briskly.
4. If the choke rod was pulled to the CLOSED position to start the engine, push it to the OPEN position as soon as the engine warms up enough to run smoothly.
5. Position the throttle control lever (gray) for the desired engine speed.

STOPPING THE ENGINE

1. Move the throttle control lever (gray) to the SLOW position.
2. Allow the engine to idle for a few seconds; then move the throttle control lever to the STOP position.

Type 2: Manual Choke, Ignition Switch Lever, Fixed Throttle

STARTING THE ENGINE

1. Move the choke rod [1] to the CLOSED position (cold engine) (see Figure 1, [page 2](#)).
2. Move the ignition switch lever (red) [4] to the ON position (see Figure 4, [page 2](#)).

Some engine applications use a remote-mounted ignition switch rather than the engine-mounted lever shown.
3. Pull the starter grip lightly until resistance is felt; then pull briskly.
4. If the choke rod was pulled to the CLOSED position to start the engine, push it to the OPEN position as soon as the engine warms up enough to run smoothly.

The engine speed is preset on this type.

STOPPING THE ENGINE

Move the ignition switch lever (red) to the OFF position (see Figure 5, [page 2](#)).

Type 3: Manual Choke, Engine Stop Switch, Fixed Throttle

Some engine applications use a remote-mounted engine stop switch rather than the engine-mounted engine stop switch shown. Refer to the instructions provided by the equipment manufacturer.

STARTING THE ENGINE

1. Move the choke rod [1] to the CLOSED position (cold engine) (see Figure 1, [page 2](#)).
2. Move the engine stop switch [2] to the ON position (see Figure 6, [page 2](#)).
3. Pull the starter grip lightly until resistance is felt; then pull briskly.
4. If the choke rod was pulled to the CLOSED position to start the engine, push it to the OPEN position as soon as the engine warms up enough to run smoothly.

The engine speed is preset on this type.

STOPPING THE ENGINE

Move the engine stop switch to the OFF position (see Figure 6, [page 2](#)).

SERVICING YOUR ENGINE

THE IMPORTANCE OF MAINTENANCE

Good maintenance is essential for safe, economical, and trouble-free operation. It will also help reduce pollution.

⚠ WARNING

Improper maintenance, or failure to correct a problem before operation, can cause a malfunction in which you can be seriously hurt or killed.

Always follow the inspection and maintenance recommendations and schedules in this Owner's Manual.

To help you properly care for your engine, the following pages include a maintenance schedule, routine inspection procedures, and simple maintenance procedures using basic hand tools. Other service tasks that are more difficult, or require special tools, are best handled by professionals and are normally performed by a Honda technician or other qualified mechanic.

The maintenance schedule applies to normal operating conditions. If you operate your engine under severe conditions, such as sustained high-load or high-temperature operation, or use in unusually wet or dusty conditions, consult your servicing dealer for recommendations applicable to your individual needs and use.

Remember that an authorized Honda servicing dealer knows your engine best and is fully equipped to maintain and repair it.

To ensure the best quality and reliability, use only new Honda Genuine parts or their equivalents for repair and replacement.

Maintenance, replacement, or repair of the emission control devices and systems may be performed by any engine repair establishment or individual, using parts that are "certified" to EPA standards.

MAINTENANCE SAFETY

Some of the most important safety precautions follow. However, we cannot warn you of every conceivable hazard that can arise in performing maintenance. Only you can decide whether or not you should perform a given task.

⚠ WARNING

Failure to properly follow maintenance instructions and precautions can cause you to be seriously hurt or killed.

Always follow the procedures and precautions in this Owner's Manual.

SAFETY PRECAUTIONS

- Make sure the engine is off before you begin any maintenance or repairs. This will eliminate several potential hazards:
 - **Carbon monoxide poisoning from engine exhaust.**
Be sure there is adequate ventilation whenever you operate the engine.
 - **Burns from hot parts.**
Let the engine and exhaust system cool before touching.
 - **Injury from moving parts.**
Do not run the engine unless instructed to do so.
- Read the instructions before you begin, and make sure you have the tools and skills required.
- To reduce the possibility of fire or explosion, be careful when working around gasoline. Use only a nonflammable solvent, not gasoline, to clean parts. Keep cigarettes, sparks, and flames away from all fuel related parts.

MAINTENANCE SCHEDULE

Perform at every indicated month/year or operating hour interval, whichever comes first. ⁽¹⁾

Regular Service Period	Item	Page
Before each use	Check: Engine oil level Check: Air filter	page 7 page 7
First month or 5 hours	Change: Engine oil	page 7
Every 3 months or 25 hours	Clean: Air filter ⁽²⁾	page 7
Every 6 months or 50 hours	Change: Engine oil ⁽³⁾ Clean: Air filter ⁽²⁾	page 7 page 7
Every year or 100 hours	6 month items above plus: Check-adjust: Spark plug Clean: Spark arrester (if equipped) Check-adjust: Idle speed ⁽⁴⁾ Clean: Fuel tank and filter ⁽⁴⁾ Check-adjust: Valve clearance ⁽⁴⁾	page 8 page 8
Every 2 years or 200 hours	Yearly items above plus: Replace: Air filter Replace: Spark plug	page 7 page 8
Every 2 years	Check: Fuel lines ⁽⁴⁾ (replace if necessary)	

(1) For commercial use, log hours of operation to determine proper maintenance intervals.

(2) Service more frequently when used in dusty areas.

(3) Change engine oil every 25 hours when used under heavy load or in high ambient temperatures.

(4) These items should be serviced by an authorized Honda servicing dealer, unless you have the proper tools and are mechanically proficient. Refer to the Honda shop manual for service procedures. See "Honda PUBLICATIONS" on [page 11](#) for ordering information.

Failure to follow this maintenance schedule could result in non-warrantable failures.

REFUELING

This engine is certified to operate on unleaded gasoline with a pump octane rating of 86 or higher (research octain rating of 91 or higher).

We recommend refueling after each use to minimize the air present in the fuel tank.

Refuel in a well-ventilated area with the engine stopped. If the engine has been running, allow it to cool first. Never refuel the engine inside a building where gasoline fumes may reach flames or sparks.

You may use regular unleaded gasoline containing no more than 10% ethanol (E10) or 5% methanol by volume. In addition, methanol must contain cosolvents and corrosion inhibitors. Use of fuels with content of ethanol or methanol greater than shown above may cause starting and/or performance problems. It may also damage metal, rubber, and plastic parts of the fuel system. In addition, ethanol is hygroscopic, which means it attracts and retains water in the fuel system. Engine damage or performance problems that result from using a fuel with percentages of ethanol or methanol greater than shown above are not covered by warranty.

If your equipment will be used on an infrequent or intermittent basis (more than 4 weeks between usage), See "AVOIDING FUEL-RELATED PROBLEMS" on [page 12](#) for additional information regarding fuel deterioration.

Never use stale or contaminated gasoline or oil/gasoline mixture. Avoid getting dirt or water in the fuel tank.

WARNING

Gasoline is highly flammable and explosive. You can be burned or seriously injured when handling fuel.

- Stop the engine and allow to cool.
- Keep heat, sparks, and flame away.
- Handle fuel only outdoors.
- Wipe up spills immediately.

Adding Fuel

See Figure 7, [page 3](#).

1. Remove the fuel tank cap.
2. Add fuel to the bottom of the fuel level limit [1] in the neck of the fuel tank. Do not overfill. Wipe up spilled fuel before starting the engine.
3. Install the fuel tank cap and tighten it until it clicks.
Move at least 10 feet (3 meters) away from the fueling source and site before starting the engine.

NOTICE

Fuel can damage paint and some types of plastic. Be careful not to spill fuel when filling your fuel tank. Damage caused by spilled fuel is not covered under your DISTRIBUTOR'S LIMITED WARRANTY.

ENGINE OIL

Oil is a major factor affecting performance and service life. Always change the oil in accordance with the maintenance schedule ([page 6](#)).

Recommended Oil

See Figure 8, [page 3](#).

Use 4-stroke motor oil that meets or exceeds the requirements for API service category SJ or later. Always check the API service label on the oil container to be sure it includes the letters SJ or later.

SAE 10W-30 is recommended for general use. Other viscosities shown in the chart may be used when the average temperature in your area is within the indicated range.

Oil Level Check

See Figure 8, [page 3](#).

1. Check the oil with the engine stopped and level.
2. Remove the oil filler cap/dipstick [1] and wipe it clean.
3. Insert the oil filler cap/dipstick into the oil filler neck as shown, but do not screw it in, and then remove it to check the oil level.
4. If the oil level is near or below the lower limit mark [2] on the dipstick, fill with the recommended oil to the upper limit mark [3]. Do not overfill.
5. Reinstall the oil filler cap/dipstick [1].

Oil Change

See Figure 9, [page 3](#).

Drain the engine oil when the engine is warm. Warm oil drains quickly and completely.

1. Place a suitable container next to the engine to catch the used oil.
2. Remove the oil filler cap/dipstick [1], and the oil drain plug [2] and washer [3].
3. Allow the used oil to drain completely; then reinstall the drain plug and new washer. Tighten the drain plug securely.

Please dispose of used motor oil in a manner that is compatible with the environment. We suggest you take used oil in a sealed container to your local recycling center or service station for reclamation. Do not throw it in the trash, pour it on the ground, or pour it down a drain.

4. With the engine in a level position, fill to the upper limit mark (bottom edge of the oil fill hole) on the dipstick with the recommended oil. Do not overfill.

Capacity: 20 oz (0.58 L)

NOTICE

Running the engine with a low oil level can cause engine damage. This type of damage is not covered by the DISTRIBUTOR'S LIMITED WARRANTY.

5. Reinstall the oil filler cap/dipstick [1] securely.

AIR CLEANER

A properly maintained air filter will help prevent dirt from entering your engine. Dirt entering the carburetor can be drawn into small passages in the carburetor and cause premature engine wear. These small passages can become blocked, causing starting or running problems. You will need to clean the filter more frequently if you operate the engine in very dusty areas.

NOTICE

Operating the engine without an air filter, or with a damaged filter, will allow dirt to enter the engine, causing rapid engine wear. This type of damage is not covered under your DISTRIBUTOR'S LIMITED WARRANTY.

We recommend the use of a Honda Genuine air filter to ensure it seals and performs as designed. Using a non-Honda air filter can result in dirt bypassing the filter, causing damage to the engine or fuel system.

Inspection

See Figure 10, [page 3](#).

1. Press the latch tabs [1] on the top of the air cleaner cover [2], and remove the cover. Check the filter [3] to be sure it is clean and in good condition.
2. Reinstall the filter and air cleaner cover.

Cleaning

1. Tap the filter several times on a hard surface to remove dirt, or blow compressed air not exceeding 30 psi (207 kPa) through the filter from the clean side that faces the engine. Never try to brush off dirt. Brushing will force dirt into the fibers.
2. Wipe dirt from the air cleaner body [4] and cover using a moist rag. Be careful to prevent dirt from entering the air duct [5] that leads to the carburetor.

SPARK PLUG

See Figure 11, [page 3](#).

Required Spark Plug: NGK - BPR6ES

The required spark plug is the correct heat range for normal engine operating temperatures.

NOTICE

Incorrect spark plugs can cause engine damage.

For good performance, the spark plug must be properly gapped and free of deposits.

1. Disconnect the cap from the spark plug, and remove any dirt from the spark plug area.
2. Use the proper size spark plug wrench [1] to remove the spark plug.
3. Inspect the spark plug. Replace it if damaged, badly fouled, if the sealing washer [2] is in poor condition, or if the electrode is worn.
4. Measure the electrode gap with a suitable gauge. The correct gap is 0.028 ~ 0.031 in (0.70 ~ 0.80 mm). If adjustment is needed, correct the gap by carefully bending the side electrode.
5. Install the spark plug carefully, by hand, to avoid cross-threading.
6. After the spark plug is seated, tighten with the proper size spark plug wrench to compress the washer.

When installing a new spark plug, tighten 1/2 turn after the spark plug seats to compress the washer.

When reinstalling the original spark plug, tighten 1/8 ~ 1/4 turn after the spark plug seats to compress the washer.

NOTICE

Properly tighten the spark plug. A loose spark plug can become very hot and can damage the engine. Overtightening the spark plug can damage the threads in the cylinder head.

7. Attach the spark plug cap to the spark plug.

SPARK ARRESTER (IF EQUIPPED)

See Figure 12, [page 3](#).

The spark arrester may be standard or an optional part, depending on the engine type. In some areas, it is illegal to operate an engine without a spark arrester. Check local laws and regulations. A spark arrester is available from authorized Honda servicing dealers.

The spark arrester must be serviced every 100 hours to keep it functioning as designed.

If the engine has been running, the muffler will be hot. Allow it to cool before servicing the spark arrester.

Removal

1. Remove the three 6 mm bolts [1] from the muffler protector [2], and remove the muffler protector.
2. Remove the 4 mm screw [3] from the spark arrester [4], and remove the spark arrester from the muffler [5].

Cleaning & Inspection

1. Use a brush to remove carbon deposits from the spark arrester screen. Be careful not to damage the screen. Replace the spark arrester if it has breaks or holes.
2. Install the spark arrester in the reverse order of removal.

STORING YOUR ENGINE

STORAGE PREPARATION

Proper storage preparation is essential for keeping your engine trouble-free and looking good. The following steps will help to keep rust and corrosion from impairing your engine's function and appearance, and will make the engine easier to start when you use it again.

CLEANING

If the engine has been running, allow it to cool for at least half an hour before cleaning. Clean all exterior surfaces, touch up any damaged paint, and coat other areas that may rust with a light film of oil.

NOTICE

Using a garden hose or pressure washing equipment can force water into the air cleaner or muffler opening. Water in the air cleaner will soak the air filter, and water that passes through the air filter or muffler can enter the cylinder, causing damage.

FUEL

See "AVOIDING FUEL-RELATED PROBLEMS" on [page 12](#).

ENGINE OIL

1. Change the engine oil (see [page 7](#)).
2. Remove the spark plug (see [page 8](#)).
3. Pour 1 - 2 teaspoons (5 ~ 10 cc) of clean engine oil into the cylinder.
4. Pull the recoil starter several times to distribute the oil.
5. Reinstall the spark plug.

STORAGE PRECAUTIONS

If your engine will be stored with gasoline in the fuel tank, it is important to reduce the hazard of gasoline vapor ignition. Select a well-ventilated storage area away from any appliance that operates with a flame, such as a furnace, water heater, or clothes dryer. Also avoid any area with a spark-producing electric motor, or where power tools are operated.

If possible, avoid storage areas with high humidity, because that promotes rust and corrosion.

Keep the engine level in storage. Tilting can cause fuel or oil leakage.

With the engine and exhaust system cool, cover the engine to keep out dust. A hot engine and exhaust system can ignite or melt some materials. Do not use sheet plastic as a dust cover. A nonporous cover will trap moisture around the engine, promoting rust and corrosion.

Removal From Storage

Check your engine as described in the *BEFORE OPERATION CHECKS* section of this manual (see [page 4](#)).

If the fuel was drained during storage preparation, fill the tank with fresh gasoline. If you keep a container of gasoline for refueling, be sure it contains only fresh gasoline. Gasoline oxidizes and deteriorates over time, causing hard starting.

If the cylinder was coated with oil during storage preparation, the engine will smoke briefly at startup. This is normal.

TRANSPORTING

Keep the engine level when transporting to reduce the possibility of fuel leakage. Turn the fuel valve to the OFF position.

Review the instructions provided with the equipment powered by this engine for any procedures that should be followed for transporting.

TAKING CARE OF UNEXPECTED PROBLEMS

Engine will not start

POSSIBLE CAUSE	CORRECTION
Choke is OFF.	Unless the engine is warm, move the choke lever to the CHOKE position.
Ignition switch or engine stop switch is OFF.	<ul style="list-style-type: none"> • Move the throttle lever to the SLOW or FAST position • Move the ignition switch lever to the ON position • Move the engine stop switch to the ON position
Engine oil level is low (oil alert models)	Fill with the recommended oil to the proper level (page 7).
Out of fuel.	Refuel
Bad fuel; engine stored without treating gasoline, or refueled with bad gasoline.	Drain the fuel tank and carburetor. Refuel with fresh gasoline.
Spark plug faulty, fouled, or improperly gapped.	Adjust or replace the spark plug (page 8).
Spark plug wet with fuel (flooded engine).	Dry and reinstall the spark plug. Start the engine with the choke in the OFF position and the throttle lever in the FAST position.
Fuel filter clogged, carburetor malfunction, ignition malfunction, valves stuck, etc.	Take the engine to an authorized Honda servicing dealer or refer to the shop manual to replace or repair faulty components as necessary.

Engine lacks power

POSSIBLE CAUSE	CORRECTION
Air filter clogged.	Clean or replace the air filter (page 7).
Bad fuel; engine stored without treating the gasoline, or refueled with bad gasoline.	Drain the fuel tank and carburetor. Refuel with fresh gasoline.
Fuel filter clogged, carburetor malfunction, ignition malfunction, valves stuck, etc.	Take the engine to an authorized Honda servicing dealer or refer to the shop manual to replace or repair faulty components as necessary.

TECHNICAL INFORMATION

SERIAL NUMBER AND TYPE LOCATION

See figures on page 1.

Record the engine serial number and type in the space below. You will need this information when ordering parts and when making technical or warranty inquiries.

MODEL	SERIAL NUMBER	TYPE
GC160 or 190	—	—
Date of purchase		

RADIO FREQUENCY INTERFERENCE LABEL (CANADA)

This engine complies with Canadian radio frequency interference regulations, ICES-002.

THIS SPARK IGNITION SYSTEM COMPLIES WITH CANADIAN ICES-002.
CE SYSTÈME D'ALLUMAGE PAR ÉTINCELLE EST CONFORME À LA NORME NMB-002 DU CANADA.

Carburetor Modifications for High Altitude Operation

At high altitude, the standard carburetor air-fuel mixture will be too rich. Performance will decrease, and fuel consumption will increase. A very rich mixture will also foul the spark plug and cause hard starting. Operation at an altitude that differs from that at which this engine was certified, for extended periods of time, may increase emissions.

High altitude performance can be improved by specific modifications to the carburetor. If you always operate your engine at altitudes above 2,000 feet (610 meters), have your servicing dealer perform this carburetor modification. This engine, when operated at high altitude with the carburetor modifications for high altitude use, will meet each emission standard throughout its useful life.

Even with carburetor modification, engine horsepower will decrease about 3.5% for each 1,000-foot (300-meter) increase in altitude. The effect of altitude on horsepower will be greater than this if no carburetor modification is made.

When using auto throttle type engines in high altitude applications, the ability to idle down to 2,500 rpm could be diminished. See your servicing dealer for information on adjustments if your auto throttle unit does not idle down with the load released or has trouble returning to full rpm with the load applied.

NOTICE

When the carburetor has been modified for high altitude operation, the air-fuel mixture will be too lean for low altitude use. Operation at altitudes below 2,000 feet (610 meters) with a modified carburetor may cause the engine to overheat and result in serious engine damage. For use at low altitudes, have your servicing dealer return the carburetor to original factory specifications.

EMISSION CONTROL SYSTEM INFORMATION

Source of Emissions

The combustion process produces carbon monoxide, oxides of nitrogen, and hydrocarbons. Control of hydrocarbons and oxides of nitrogen is very important because, under certain conditions, they react to form photochemical smog when subjected to sunlight. Carbon monoxide does not react in the same way, but it is toxic.

Honda utilizes appropriate air/fuel ratios and other emissions control systems to reduce the emissions of carbon monoxide, oxides of nitrogen, and hydrocarbons. Additionally, Honda fuel systems utilize components and control technologies to reduce evaporative emissions.

The U.S. and California Clean Air Acts, and Environment and Climate Change Canada (ECCC)

U.S. EPA, California, and Canadian regulations require all manufacturers to furnish written instructions describing the operation and maintenance of emission control systems.

The following instructions and procedures must be followed in order to keep the emissions from your Honda engine within the emission standards.

Tampering and Altering

NOTICE

Tampering is a violation of federal and California law.

Tampering with or altering the emission control system may increase emissions beyond the legal limit. Among those acts that constitute tampering are:

- Removal or alteration of any part of the intake, fuel, or exhaust systems.
- Alterations that would cause the engine to operate outside its design parameters.

Problems That May Affect Emissions

If you are aware of any of the following symptoms, have your engine inspected and repaired by your authorized Honda Power Equipment dealer.

- Hard starting or stalling after starting.
- Rough idle.
- Misfiring or backfiring under load.
- Afterburning (backfiring).
- Black exhaust smoke or high fuel consumption.

Replacement Parts

The emissions control systems on your new Honda engine were designed, built, and certified to conform with EPA, California (models certified for sale in California), and Canadian emissions regulations. We recommend the use of Honda Genuine parts whenever you have maintenance done. These original-design replacement parts are manufactured to the same standards as the original parts, so you can be confident of their performance. Honda cannot deny coverage under the emission warranty solely for the use of non-Honda replacement parts or service performed at a location other than an authorized Honda dealership; you may use comparable EPA certified parts, and have service performed at non-Honda locations. However, the use of replacement parts that are not of the original design and quality may impair the effectiveness of your emissions control system.

A manufacturer of an aftermarket part assumes the responsibility that the part will not adversely affect emissions performance. The manufacturer or rebuilder of the part must certify that use of the part will not result in a failure of the engine to comply with emissions regulations.

Maintenance

As the power equipment engine owner, you are responsible for completing all required maintenance listed in your owner's manual. Honda recommends that you retain all receipts covering maintenance on your power equipment engine, but Honda cannot deny warranty coverage solely for the lack of receipts or for your failure to ensure that all scheduled maintenance has been completed.

Follow the maintenance schedule on [page 6](#). Remember that this schedule is based on the assumption that your Honda engine product will be used for its designed purpose. Sustained high-load or high-temperature operation, or use in dusty conditions, will require more frequent service.

Air Index

An Air Index Information label is applied to engines certified to an emission durability time period in accordance with the requirements of the California Air Resources Board.

The bar graph is intended to provide you, our customer, the ability to compare the emissions performance of available engines. The lower the Air Index, the less pollution.

The durability description is intended to provide you with information relating the engine's emission durability period. The descriptive term indicates the useful life period for the engine's emission control system. See your *EMISSION CONTROL SYSTEM WARRANTY* ([page 15](#)) for additional information.

DESCRIPTIVE TERM	APPLICABLE TO EMISSION DURABILITY PERIOD
Moderate	50 hours (0–80 cc inclusive) 125 hours (greater than 80 cc)
Intermediate	125 hours (0–80 cc inclusive) 250 hours (greater than 80 cc)
Extended	300 hours (0–80 cc inclusive) 500 hours (greater than 80 cc) 1000 hours (225 cc and greater)

Specifications

GC160

Length x Width x Height	13.3 x 14.7 x 13.0 in (337 x 372.5 x 331 mm)
Dry weight	25 lb (11.5 kg)
Engine type	4-stroke, overhead cam, single cylinder
Displacement [Bore x Stroke]	9.8 cu-in (160 cm ³) [2.5 x 2.0 in (64 x 50 mm)]
Oil capacity	20 oz (0.58 L)
Fuel tank capacity	0.48 gal (1.8 L)
Cooling system	Forced air
Ignition system	Transistorized magneto
PTO shaft rotation	Counterclockwise

GC190

Length x Width x Height	13.6 x 14.7 x 13.0 in (345 x 372.5 x 331 mm)
Dry weight	29 lb (13.2 kg)
Engine type	4-stroke, overhead cam, single cylinder
Displacement [Bore x Stroke]	11.4 cu-in (187 cm ³) [2.7 x 2.0 in (69 x 50 mm)]
Oil capacity	20 oz (0.58 L)
Fuel tank capacity	0.48 gal (1.8 L)
Cooling system	Forced air
Ignition system	Transistorized magneto
PTO shaft rotation	Counterclockwise

Tuneup Specifications

ITEM	SPECIFICATION	MAINTENANCE
Spark plug gap	0.028 ~ 0.031 in (0.7 ~ 0.8 mm)	Refer to page 8 .
Valve clearance (cold)	IN: 0.15 ± 0.04 mm EX: 0.20 ± 0.04 mm	See your authorized Honda dealer
Other specifications	No other adjustments needed.	

Quick Reference Information

ITEM	DESCRIPTION	
Fuel	Type	Unleaded gasoline with a pump octane rating of 86 or higher (page 7).
Engine Oil	Type	SAE 10W-30, API SJ or later, for general use. Refer to page 7 .
Carburetor	Idle Speed	1,400 ± 150 rpm
Spark plug	Type	BPR6ES (NGK)
Maintenance	Before each use	Check engine oil level. Refer to page 7 . Check air filter. Refer to page 7 .
	First 5 hours	Change engine oil. Refer to page 7 .
	Subsequent	Refer to the maintenance schedule on page 6 .

Wiring Diagrams

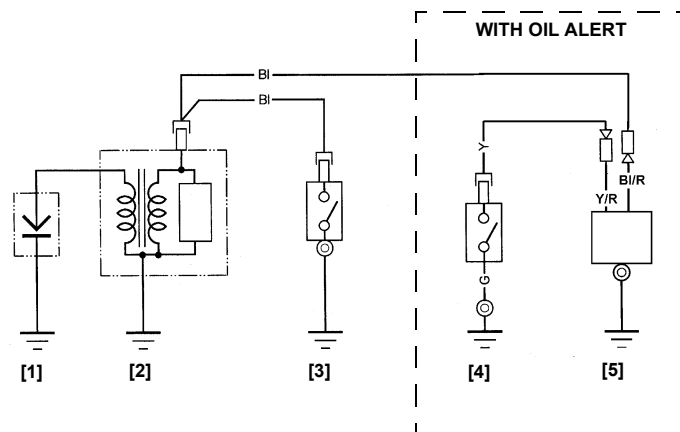

Bl	Black	Br	Brown
Y	Yellow	O	Orange
Bu	Blue	Lb	Light blue
G	Green	Lg	Light green
R	Red	P	Pink
W	White	Gr	Gray

ENGINE	SWITCH POSITION
RUN	OPEN
STOP	CLOSED

OIL LEVEL	SWITCH POSITION	ENGINE
NORMAL	OPEN	RUN
LOW LEVEL	CLOSED	STOP

[1]	SPARK PLUG	[4]	OIL LEVEL SWITCH
[2]	IGNITION COIL	[5]	OIL ALERT UNIT
[3]	IGNITION SWITCH		

CONSUMER INFORMATION

DISTRIBUTOR/DEALER LOCATOR INFORMATION

United States, Puerto Rico, and U.S. Virgin Islands:

Visit our website: www.engines.honda.com

Canada:

Call (888) 9HONDA9 [888 946-6329]

or visit our website: www.honda.ca

Honda PUBLICATIONS

These publications will give you additional information for maintaining and repairing your engine.

Shop Manual	This manual covers complete maintenance and overhaul procedures. It is intended to be used by a skilled technician. Available through your Honda dealer or visit engines.honda.com .
Parts Catalog	This manual provides complete, illustrated parts lists. Available through your Honda dealer.

AVOIDING FUEL-RELATED PROBLEMS

GC ENGINE POWERED PRODUCTS

When properly maintained, your Honda powered product should provide years of trouble-free operation. This includes the fuel system. However, gasoline can quickly deteriorate (in as little as 30 days) causing starting or running problems and, in some cases, damage to the fuel system. Most fuel-related problems can be avoided by following the precautions listed below. Fuel system damage and engine performance problems resulting from deteriorated gasoline are not covered by the *DISTRIBUTOR'S LIMITED WARRANTY*.

Follow These Precautions to Prevent Most Fuel-Related Problems

During the Operating Season	Reason
Do not use gasoline containing more than 10% ethanol (E10). Not all automotive gasoline is safe to use in your power product.	Higher levels of ethanol in gasoline attract water, and can corrode or damage the fuel system and cause performance problems.
Store gasoline in a clean, plastic, sealed container approved for fuel storage. Store your fuel supply container away from direct sunlight; if the container has a vent, keep it closed.	A plastic container eliminates the risk of rust and metallic contaminants from a metal container entering the fuel system. Gasoline will deteriorate faster when exposed to air and sunlight.
Purchase only enough gasoline to last for 1 to 2 months (about 30 to 60 days). If you purchase enough gasoline to last for more than 60 days, add a fuel stabilizer to your storage container when you fill it.	Gasoline deteriorates with age so try to avoid storing it for long periods, especially in summer heat. Fuel stabilizer will extend the shelf life of gasoline, but it will not reconstitute stale fuel.
Keep your product's fuel tank full of fresh fuel when not in use.	If the fuel tank is only partially filled, air in the tank will promote fuel deterioration.
Keep the air filter clean and properly serviced. Check it before each use.	A properly maintained air filter will help prevent dirt from entering the carburetor. The small passages inside the carburetor can become blocked.

1 to 3 Months Before Next Use	Reason
If you did not add fuel stabilizer to your fuel storage container when you filled it up, fill your product's fuel tank with fresh gasoline.	If the fuel tank is only partially filled, air in the tank will promote fuel deterioration.
Add fuel stabilizer to the product's fuel tank according to the stabilizer manufacturer's instructions.	Fuel stabilizer will extend the life of gasoline, but it will not reconstitute stale gasoline.
Run the engine outdoors for 10 minutes.	This makes sure treated gasoline has replaced untreated gasoline throughout the fuel system.

More Than 3 Months Before Next Use	Reason
Use a siphon pump (commercially available) and siphon the fuel out of the fuel tank into an approved gasoline container and then drain the carburetor. (see Figure 13, page 3). Do not allow gasoline to remain in your product's fuel tank for more than 3 months (about 90 days) of inactivity.	All fuel stabilizers have a shelf life. It is good practice to empty the fuel system for long term inactivity.

CUSTOMER SERVICE INFORMATION

Servicing dealership personnel are trained professionals. They should be able to answer any question you may have. If you encounter a problem that your dealer does not solve to your satisfaction, please discuss it with the dealership's management. The Service Manager, General Manager, or Owner can help. Almost all problems are solved in this way.

If you are dissatisfied with the decision made by the dealership's management, contact the Honda Regional Engine Distributor for your area. You can find their name, address, and phone number using the dealer/distributor locator on our website at www.engines.honda.com

If you are still dissatisfied after speaking with the Regional Engine Distributor, you may contact the Honda Office as shown below.

<Honda's Office>

When you write or call, please provide this information:

- Equipment manufacturer's name and model number that the engine is mounted on
- Engine model, serial number, and type (see [page 9](#))
- Name of dealer who sold the engine to you
- Name, address, and contact person of the dealer who services your engine
- Date of purchase
- Your name, address and telephone number
- A detailed description of the problem

United States, Puerto Rico, and U.S. Virgin Islands:

American Honda Motor Co., Inc.

Power Equipment Division
Customer Relations Dept.
4900 Marconi Drive
Alpharetta, GA 30005-8847

Or telephone: (770) 497-6400, 8:30 a.m. - 7:00 p.m. ET

Canada:

Honda Canada, Inc.

180 Honda Blvd, Markham, ON L6C 0H9
or visit: www.honda.ca

Telephone: (888) 9HONDA9 Toll free
(888) 946-6329

Facsimile: (877) 939-0909 Toll free

DISTRIBUTOR'S WARRANTIES

The applicable warranty is the warranty policy in effect in the country where the warranty service is provided.

Distributor's Limited Warranty

United States, Puerto Rico, or the U.S. Virgin Islands

PRODUCTS COVERED BY THIS WARRANTY:	LENGTH OF WARRANTY: (FROM DATE OF ORIGINAL PURCHASE)	
	PRIVATE/RESIDENTIAL (1)	COMMERCIAL/RENTAL/INSTITUTIONAL (2)
GC Series Engines	24 months	3 months

(1) Private Residential: Used in maintaining owner's primary and/or secondary residence. Any other use, including but not limited to informal "for hire" use, is considered commercial/rental/institutional.

(2) Honda GC general purpose engines are not covered by this warranty when installed on concession type vehicles.

To Qualify for this Warranty:

The Honda general purpose engine must be purchased from a Honda general purpose engine dealer authorized to sell that product in the United States, Puerto Rico, or the U.S. Virgin Islands. This limited warranty applies to the first retail purchaser and each subsequent owner during the applicable warranty time period.

What American Honda Will Repair or Replace Under Warranty:

American Honda will repair or replace, at its option, any part that is proven to be defective in material or workmanship under normal use during the applicable warranty time period. Warranty repairs and replacements will be made without charge for parts or labor. Anything replaced under warranty becomes the property of American Honda Motor Co., Inc. All parts replaced under warranty will be considered as part of the original product and any warranty on those parts will expire coincident with the original product warranty.

To Obtain Warranty Service:

You must take your Honda general purpose engine, or the equipment in which it is installed, together with proof of original retail purchase date, at your expense, to a Honda engine dealer authorized to sell that product in the United States, Puerto Rico, or the U.S. Virgin Islands, during their normal business hours. To locate a dealer near you, visit our web site at <http://engines.honda.com> and click on FIND A DEALER.

If you are unable to obtain warranty service, or are dissatisfied with the warranty service you receive, take the following steps: First, contact the owner of the dealership involved; normally this should resolve the problem. However, if you should require further assistance, write or call the Power Equipment Customer Relations Department of American Honda Motor Co., Inc.

Exclusions:

This engine warranty does not include the following:

- Any damage or deterioration resulting from the following:
 - Neglect of the periodic maintenance as specified in the engine owner's manual
 - Improper repair or maintenance
 - Operating methods other than those indicated in the engine owner's manual
 - Damage caused by the product on which the engine is installed
 - Damage caused by conversion to, or use of, fuel other than the fuel(s) that the engine was originally manufactured to use, as set forth in the engine owner's manual and/or warranty booklet
 - The use of non-genuine Honda parts and accessories, other than those approved by Honda (other than recommended lubricants and fluids) (does not apply to the emissions warranty unless non-genuine part used is not comparable to Honda part and was cause of the failure)
 - Exposure of the product to soot and smoke, chemical agents, bird droppings, sea water, sea breeze, salt or other environmental phenomena
 - Collision, fuel contamination or deterioration, neglect, unauthorized alteration, or misuse
 - Natural wear and tear (natural fading of painted or plated surfaces, sheet peeling and other natural deterioration)
- American Honda is an engine supplier to original equipment manufacturers (OEMs) to power their products, such as pressure washers, lawn mowers, log splitters, etc. In the case where an OEM supplies parts, including emission related parts (e.g. muffler), please refer to the OEM for warranty coverage and support.
- Consumable parts: Honda does not warrant parts deterioration due to normal wear and tear. The parts listed below are not covered by warranty (unless they are needed as a part of another warranty repair):
 - Spark plug, fuel filter, air cleaner element, clutch disc, recoil starter rope
 - Lubricant: oil and grease
- Cleaning, adjustment, and normal periodic maintenance work (carburetor cleaning and engine oil draining).
- Use of the Honda general purpose engine for racing or competition.
- Any engine that is part of a product that has ever been declared a total loss or sold for salvage by a financial institution or insurer.

Disclaimer of Consequential Damage and Limitation of Implied Warranties:

American Honda disclaims any responsibility for loss of time or use of the engine, or the equipment in which the engine is installed, transportation, commercial loss, or any other incidental or consequential damage. Any implied warranties are limited to the duration of this written limited warranty. Some states do not allow limitations on how long an implied warranty lasts and/or do not allow the exclusion or limitation of incidental or consequential damages, so the above exclusions and limitations may not apply to you.

This warranty gives you specific legal rights, and you may also have other rights, which vary from state to state.

PWL50372-R

Distributor's Warranty Canada

Honda Canada Inc., for and on behalf of Honda Motor Co. Ltd., Tokyo, Japan, gives the following written warranty on each new General Purpose Engine manufactured by Honda Motor Co. Ltd., Japan, distributed in Canada by Honda Canada Inc. and sold as part of the original equipment of machinery or equipment when such machinery or equipment is manufactured in Canada. Whenever used herein, the word "Honda" refers to Honda Canada Inc. and/or Honda Motor Co. Ltd. as appropriate from the context.

Honda warrants that each new Honda General Purpose Engine will be free, under normal use and maintenance, from any defects in material or workmanship for the relevant warranty period set forth below. If any defects should be found in a Honda General Purpose Engine within the relevant warranty period, necessary repairs and replacements with a new part or the Honda equivalent shall be made at no cost to the consumer for parts and labour (except for labour charges due to the presence of an attachment), when Honda acknowledges that such defects are attributable to faulty material or workmanship at the time of manufacture.

WARRANTY PERIOD

Warranty coverage commences from the original date of sale or when the unit is first put into use as a demonstrator. The following warranty applies to power products purchased at retail or placed into rental service on or after August 1, 2011.

MODEL	NON-COMMERCIAL	COMMERCIAL	RENTAL	CONCESSION
GC160 GC190	24 months	3 months	3 months	NONE

NOTE: Concession use refers to Go Karts, etc.

THIS WARRANTY COVERS:

- Any Honda General Purpose Engine purchased from a Honda general purpose engine dealer or distributor authorized to sell that product in Canada.
- Any factory installed part (except normal maintenance parts referred to in "THIS WARRANTY DOES NOT COVER"); and
- Any General Purpose Engine on which required maintenance services have been performed as prescribed in the Owner's Manual.

THIS WARRANTY DOES NOT INCLUDE THE FOLLOWING:

- Any damage or deterioration resulting from the following:
 - Neglect of the periodic maintenance as specified in the engine owner's manual
 - Improper repair or maintenance
 - Operating methods other than those indicated in the engine owner's manual
 - Damage caused by the product on which the engine is installed
 - Damage caused by conversion to, or use of, fuel other than the fuel(s) that the engine was originally manufactured to use, as set forth in the engine owner's manual.
 - The use of non-genuine Honda parts and accessories, other than those approved by Honda (other than recommended lubricants and fluids) (does not apply to the emissions warranty unless non-genuine part used is not comparable to Honda part and was cause of the failure)
 - Exposure of the product to soot and smoke, chemical agents, bird droppings, sea water, salt or other corrosive environments
 - Collision, fuel contamination or deterioration, neglect, unauthorized alteration, or misuse
 - Natural wear and tear (natural fading of painted or plated surfaces, sheet peeling and other natural deterioration)
- Consumable parts: Honda does not warrant parts deterioration due to normal wear and tear. The parts listed below are not covered by warranty (unless they are needed as a part of another warranty repair):
 - Spark plug, fuel filter, air cleaner element, clutch disc, recoil starter rope
 - Lubricant: oil and grease
- Cleaning, adjustment, and normal periodic maintenance work (carburetor cleaning and engine oil draining).
- Use of the Honda general purpose engine for racing or competition.
- Any engine that is part of a product that has ever been declared a total loss or sold for salvage by a financial institution or insurer.

THE OWNER'S OBLIGATION

In order to maintain the validity of this *DISTRIBUTOR'S WARRANTY*, the required maintenance services as set forth in the Owner's Manual must be performed at the proper intervals and detailed receipts and records retained as proof.

TO OBTAIN WARRANTY SERVICE

You must take your Honda General Purpose Engine, at your expense, during normal service hours, to the authorized Honda Power Products dealer or the dealer designated by the manufacturer of the machinery or equipment powered by the Honda engine. If you are unable to obtain or are dissatisfied with the warranty service you receive, first contact the owner of the dealership involved; this should resolve the problem. If you require further assistance, contact Honda Canada Inc., at the address shown under *Customer Service Information* (page 13).

REPLACEMENT PARTS WARRANTY

New Honda Genuine replacement parts sold to a consumer or installed by an authorized Honda power equipment dealer which are not covered by the *DISTRIBUTOR'S WARRANTY* are warranted for a period of one year from date of purchase for normal use, or 3 months for rental or concession use provided, however, that this Replacement Parts Warranty does not apply to any replacement parts modified, used with, or installed on a power product for which the replacement parts were not intended. Electrical components that are not installed by the dealer (sold over the counter) are not covered by warranty.

ENTIRE WRITTEN WARRANTY

This *DISTRIBUTOR'S WARRANTY* is the only and the entire written warranty given by Honda for Honda General Purpose Engines. No dealer or his agent or employee is authorized to extend or enlarge on these warranties on behalf of Honda by any written or verbal statement or advertisement.

DISCLAIMER

To the extent the law permits, Honda disclaims any responsibility for loss of time or use of the General Purpose Engine, transportation or towing costs or any other indirect, incidental or consequential damage, inconvenience or commercial loss.

NOTICE TO CONSUMER

The provisions contained in these written warranties are not intended to limit, modify, take away from, disclaim or exclude any warranties set forth in or the operation of The Consumer Products Warranties Act, 1977 (Saskatchewan), The Consumer Product Warranty and Liability Act (New Brunswick), The Consumer Protection Act (Quebec), or any other similar provincial or federal legislation.

PRIVACY STATEMENT

The owner information submitted may be used by Honda and its related companies, their dealers and service providers to communicate marketing, product and service information to you. If you prefer not to receive marketing information, please contact us at 1-888-946-6329.

EMISSION CONTROL SYSTEM WARRANTY

Your new Honda Power Equipment engine complies with the U.S. EPA, Environment Canada, and State of California (models certified for sale in California only) emission regulations. American Honda Motor Co., Inc. provides the emission warranty coverage for engines in the United States and its territories. Honda Canada Inc. provides the emission warranty for engines in the 13 provinces and territories of Canada. In the remainder of this Emission Control System Warranty, American Honda Motor Co., Inc. and Honda Canada Inc. will be referred to as Honda.

CALIFORNIA EXHAUST AND EVAPORATIVE EMISSIONS CONTROL WARRANTY STATEMENT

YOUR WARRANTY RIGHTS AND OBLIGATIONS

The California Air Resources Board and Honda are pleased to explain the exhaust and evaporative emissions ("emissions") control system warranty on your 2021 and later Honda Power Equipment engine. In California, new equipment that use small off-road engines must be designed, built, and equipped to meet the State's stringent anti-smog standards. Honda must warrant the emissions control system on your power equipment engine for the periods of time listed below provided there has been no abuse, neglect, or improper maintenance of your small off-road engine or equipment leading to the failure of the emissions control system.

Your emissions control system may include parts such as the carburetor or fuel-injection system, the ignition system, catalytic converter, fuel tanks, fuel lines (for liquid fuel and fuel vapors), fuel caps, valves, canisters, filters, clamps and other associated components. Also included may be hoses, belts, connectors, and other emission-related assemblies (see adjacent column for additional covered parts).

Where a warrantable condition exists, Honda will repair your power equipment engine at no cost to you including diagnosis, parts and labor.

MANUFACTURER'S WARRANTY COVERAGE:

The exhaust and evaporative emissions control system on your Honda power equipment engine is warranted for two years. If any emissions-related part on your Honda power equipment engine is defective, the part will be repaired or replaced by Honda.

OWNER'S WARRANTY RESPONSIBILITY:

- As the power equipment engine owner, you are responsible for the performance of the required maintenance listed in your owner's manual. Honda recommends that you retain all receipts covering maintenance on your power equipment engine, but Honda cannot deny warranty coverage solely for the lack of receipts or for your failure to ensure the performance of all scheduled maintenance.
- As the power equipment engine owner, you should however be aware that Honda may deny you warranty coverage if your power equipment engine or a part has failed due to abuse, neglect, improper maintenance, or unapproved modifications.
- You are responsible for presenting your power equipment engine to a Honda Power Equipment servicing dealer as soon as the problem exists. The warranty repairs shall be completed in a reasonable amount of time, not to exceed 30 days.

If you have any questions regarding your warranty rights and responsibilities, you should contact the Honda office in your region:

American Honda Motor Co., Inc.
Power Equipment
Customer Relations
4900 Marconi Drive
Alpharetta, Georgia 30005-8847
Telephone: (888) 888-3139
Email: powerequipmentemissions@ahm.honda.com

Honda Canada Inc.
Power Equipment
Customer Relations
180 Honda Blvd.
Markham, ON, L6C 0H9
Telephone: (888) 946-6329

YOUR WARRANTY RIGHTS AND OBLIGATIONS

Other States, U.S. territories, and Canada:

In other areas of the United States and in Canada, your engine must be designed, built, and equipped to meet the U.S. EPA and Environment Canada emission standards for spark-ignited engines at or below 19 kilowatts.

Specific Honda products that do not meet the California emissions regulations can be identified by a "California: Not for sale or use" or "California: Only for use in Farming or Construction Equipment" decal.

All of the United States and Canada:

The exhaust and evaporative emissions control system on your Honda power equipment engine sold in the United States and Canada is warranted for two years from the date of delivery to the ultimate purchaser or the length of the Honda Distributor's Limited Warranty, whichever is longer. This warranty is transferable to each subsequent purchaser for the duration of the warranty period.

If any emissions-related part on your Honda power equipment engine is defective, the part will be repaired or replaced by Honda. All defective parts replaced under this warranty become the property of Honda. Only Honda approved replacement parts may be used in the performance of any warranty

repairs and must be provided without charge to the owner. A list of warranted parts is shown at the bottom of this column. All emission related parts are under warranty for the remainder of the warranty period. Normal maintenance items, such as spark plugs and filters, that are on the warranted parts list are warranted up to their required replacement interval only.

Honda will also replace other engine components damaged by a failure of any warranted part during the warranty period. Honda cannot deny coverage under the emission warranty solely for use of non-Honda replacement parts or service performed at a location other than an authorized Honda dealership; however, use of a part that is not functionally identical to the original equipment part in any respect that may in any way affect emissions (including durability) could result in denial of coverage. If such a non-Honda replacement part is used in the repair or maintenance of your engine, and an authorized Honda dealer determines it is defective or causes a failure of a warranted part, your claim for repair of your engine may be denied. If the part in question is not related to the reason your engine requires repair, your claim will not be denied.

TO OBTAIN WARRANTY SERVICE:

You must, at your own expense, take your Honda Power Equipment engine or the product on which it is installed, along with your sales registration card or other proof of original purchase date, to any Honda Power Equipment dealer who is authorized by Honda to sell and service that Honda product during their normal business hours. Claims for repair or adjustment found to be caused solely by defects in material or workmanship will not be denied because the engine was not properly maintained and used.

If you are unable to obtain emission warranty service or are dissatisfied with the warranty service you received, contact the owner of the dealership involved. Normally this should resolve your problem. However, if you require further assistance, contact the Honda office in your region:

EXCLUSIONS:

Failures other than those resulting from defects in material or workmanship are not covered by this warranty. This warranty does not extend to emission control systems or parts that are affected or damaged by owner abuse, neglect, improper maintenance, or unapproved modifications.

This warranty does not cover replacement of expendable maintenance items made in connection with required maintenance service after the item's first scheduled replacement as listed in the maintenance section of the product owner's manual, such as: spark plugs and filters.

DISCLAIMER OF CONSEQUENTIAL DAMAGE AND LIMITATION OF IMPLIED WARRANTIES:

American Honda Motor Co., Inc. and Honda Canada Inc. disclaim any responsibility for incidental or consequential damages such as loss of time or the use of the power equipment, or any commercial loss due to the failure of the equipment; and any implied warranties are limited to the duration of this written warranty. This warranty is applicable only where the California, U.S. EPA, or Environment Canada emission control system warranty regulation is in effect.

EMISSION CONTROL SYSTEM WARRANTY PARTS:

SYSTEMS COVERED BY THIS WARRANTY:	PARTS DESCRIPTION:
Fuel Metering	Carburetor assembly (includes starting enrichment system), Oxygen sensor, Throttle body, Engine temperature sensor, Engine control module, Fuel injector, Fuel regulator, Intake manifold
Evaporative	Fuel tank, Fuel cap, Fuel lines (for liquid and fuel vapors), Carbon canister, Canister mounting brackets, Fuel line fittings, Fuel strainer, Fuel valve, Fuel pump, Fuel hose joint, Canister purge port connector
Exhaust	Catalyst, Exhaust pipe, Muffler (with catalyst), Exhaust manifold
Air Induction	Air cleaner case, Air cleaner element*
Ignition	Flywheel comp., Flywheel magneto, Ignition pulse generator, Crankshaft position sensor, Power coil, Ignition coil assembly, Ignition control module, Spark plug cap, Spark plug*
Crankcase Emission Control	Crankcase breather tube, Breather valve assembly, Oil filler cap
Miscellaneous Parts	Tubing, fittings, seals, gaskets, and clamps associated with these listed systems.

* Covered up to the first required replacement only. See the Maintenance Schedule on page 6.

PWL50975-V

HONDA

The Power of Dreams