

***If you have questions or comments, contact us.
Pour toute question ou tout commentaire, nous contacter.
Si tiene dudas o comentarios, contáctenos.***

1-888-895-4549 • www.dewalt.com

**INSTRUCTION MANUAL
GUIDE D'UTILISATION
MANUAL DE INSTRUCCIONES**

**INSTRUCTIVO DE OPERACIÓN, CENTROS DE SERVICIO Y
PÓLIZA DE GARANTÍA. **ADVERTENCIA:** LÉASE ESTE
INSTRUCTIVO ANTES DE USAR EL PRODUCTO.**

DEWALT®

DXCMV5248069

Two Stage, Belt Drive, Electric Air Compressors

Compresseurs d'air électriques à un étage à entraînement par courroie

Compresores eléctricos de aire, de una sola etapa y accionamiento por correa

Air Compressor

- A. Pump Air Intake Filter
- B. Auto(-)/Off(O) Switch
- C. Air Tank Pressure Gauge
- D. Regulated Pressure Gauge
- E. Pressure Regulator
- F. Air Outlet
- G. Safety Valve
- H. Air Tank Drain Valve
- I. Pump Oil Fill Plug
- J. Pump Oil Drain Plug
- K. Check Valve
- L. Quick Connect (2)

Pump Specifications

2 Cylinder

Two Stage

Oil Lubricated

Cast iron crankcase, cylinder, and head

Weight: 150 lbs. (68 kg.)

Oil Capacity: 18.5 oz. (547 mL)

Specifications

MODEL	DXCMV5248069
WEIGHT	471 lbs. (214 kg)
HEIGHT	76.13"
WIDTH	31.625"
AIR TANK CAPACITY	80 gallons (302,8 liters)
APPROX. BLOW OFF PRESSURE	200 psi

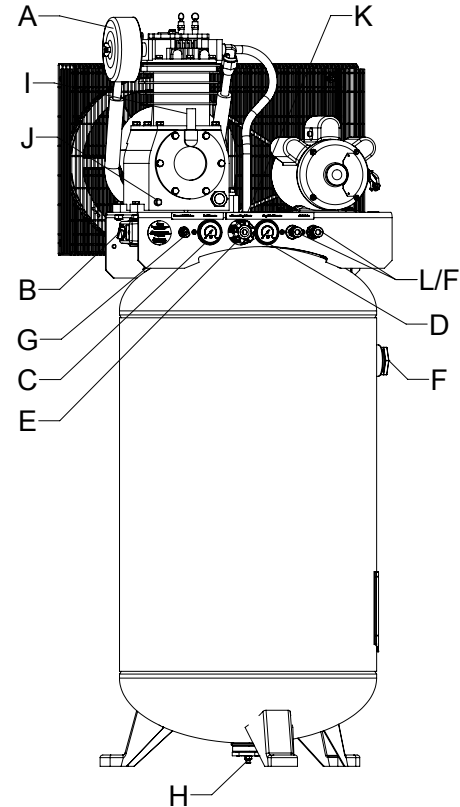

FIG. 1

Hot Surfaces

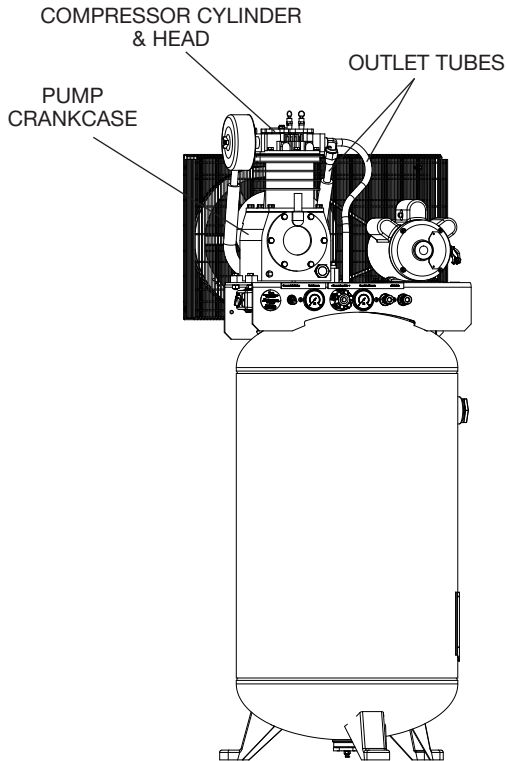

FIG. 2

Definitions: Safety Guidelines

The definitions below describe the level of severity for each signal word. Please read the manual and pay attention to these symbols.

⚠ DANGER: Indicates an imminently hazardous situation which, if not avoided, **will** result in **death or serious injury**.

⚠ WARNING: Indicates a potentially hazardous situation which, if not avoided, **could** result in **death or serious injury**.

⚠ CAUTION: Indicates a potentially hazardous situation which, if not avoided, **may** result in **minor or moderate injury**.

NOTICE: Indicates a practice **not related to personal injury** which, if not avoided, **may** result in **property damage**.

IF YOU HAVE ANY QUESTIONS OR COMMENTS ABOUT THIS OR ANY DEWALT TOOL, CALL US TOLL FREE AT: **1-888-895-4549**

Important Safety Instructions

⚠ WARNING: Do not operate this unit until you read this instruction manual for safety, operation and maintenance instructions.

⚠ WARNING: CALIFORNIA PROPOSITION 65 WARNING: This product contains chemicals known to the State of California to cause cancer, and birth defects or other reproductive harm. **Wash hands after handling.**

⚠ WARNING: Some dust contains chemicals known to the State of California to cause cancer, birth defects or other reproductive harm such as asbestos and lead in lead based paint.

SAVE THESE INSTRUCTIONS



⚠ **DANGER: RISK OF EXPLOSION OR FIRE**

WHAT CAN HAPPEN

- It is normal for electrical contacts within the motor and pressure switch to spark.
- If electrical sparks from compressor come into contact with flammable vapors, they may ignite, causing fire or explosion.
- Restricting any of the compressor ventilation openings will cause serious overheating and could cause fire.

HOW TO PREVENT IT

- Always operate the compressor in a well ventilated area free of combustible materials, gasoline, or solvent vapors.
- If spraying flammable materials, locate compressor at least 20' (6.1 m) away from spray area. An additional length of air hose may be required.
- Store flammable materials in a secure location away from compressor.
- Never place objects against or on top of compressor.
- Operate compressor in an open area at least 12" (30.5 cm) away from any wall or obstruction that would restrict the flow of fresh air to the ventilation openings.
- Operate compressor in a clean, dry well ventilated area. Do not operate unit in any confined area. Store indoors.

- Unattended operation of this product could result in personal injury or property damage. To reduce the risk of fire, do not allow the compressor to operator unattended
- Always remain in attendance with the product when it is operating.
- Always turn off and disconnect electrical supply from unit when not in use.



⚠ **DANGER: RISK TO BREATHING (ASPHYXIATION)**

WHAT CAN HAPPEN

- The compressed air directly from your compressor is not safe for breathing. The air stream may contain carbon monoxide, toxic vapors, or solid particles from the air tank. Breathing these contaminants can cause serious injury or death.
- Exposure to chemicals in dust created by power sanding, sawing, grinding, drilling and other construction activities may be harmful.
- Sprayed materials such as paint, paint solvents, paint remover, insecticides, weed killers, may contain harmful vapors and poisons.

HOW TO PREVENT IT

- Never use air obtained directly from the compressor to supply air for human consumption. The compressor is not equipped with suitable filters and in-line safety equipment for human consumption.
- Work in an area with good cross ventilation. Read and follow the safety instructions provided on the label or safety data sheets for the materials you are spraying. Always use certified safety equipment: NIOSH/OSHA respiratory protection or properly fitting face mask designed for use with your specific application.



⚠ DANGER: RISK OF BURSTING

Air Tank: On February 26, 2002, the U.S. Consumer Product Safety Commission published Release # 02-108 concerning air compressor tank safety:

Air compressor receiver tanks do not have an infinite life. Tank life is dependent upon several factors, some of which include operating conditions, ambient conditions, proper installations, field modifications, and the level of maintenance. The exact effect of these factors on air receiver life is difficult to predict.

If proper maintenance procedures are not followed, internal corrosion to the inner wall of the air receiver tank can cause the air tank to unexpectedly rupture allowing pressurized air to suddenly and forcefully escape, posing risk of injury to consumers.

Your compressor air tank must be removed from service by the end of the year shown on your tank warning label.

The following conditions could lead to a weakening of the air tank, and result in a violent air tank explosion:

WHAT CAN HAPPEN

- Failure to properly drain condensed water from air tank, causing rust and thinning of the steel air tank.
- Modifications or attempted repairs to the air tank.

HOW TO PREVENT IT

- Drain air tank daily or after each use. If air tank develops a leak, replace it immediately with a new air tank or replace the entire compressor.
- Never drill into, weld or make any modifications to the air tank or its attachments. Never attempt to repair a damaged or leaking air tank. Replace with a new air tank.

- Unauthorized modifications to the safety valve, or any other components which control air tank pressure.
- The air tank is designed to withstand specific operating pressures. Never make adjustments or parts substitutions to alter the factory set operating pressures.

Attachments & Accessories:

- Exceeding the pressure rating of air tools, spray guns, air operated accessories, tires and other inflatables can cause them to explode or fly apart, and could result in serious injury.
- Follow the equipment manufacturers recommendation and never exceed the maximum allowable pressure rating of attachments. Never use compressor to inflate small low pressure objects such as children's toys, footballs, basketballs, etc.

Tires:

- Over inflation of tires could result in serious injury and property damage.
 - Use a tire pressure gauge to check the tires pressure before each use and while inflating tires; see the tire sidewall for the correct tire pressure.
- NOTE: Air tanks, compressors and similar equipment used to inflate tires can fill small tires very rapidly. Adjust pressure regulator on air supply to no more than the rating of the tire pressure. Add air in small increments and frequently use the tire gauge to prevent over inflation.



⚠ DANGER: RISK OF INJURY OR PROPERTY DAMAGE WHEN TRANSPORTING OR STORING

WHAT CAN HAPPEN

- Oil can leak or spill and could result in fire or breathing hazard; serious injury or death can result. Oil leaks will damage carpet, paint or other surfaces in vehicles or trailers.

HOW TO PREVENT IT

- Always place compressor on a protective mat when transporting to protect against damage to vehicle from leaks. Remove compressor from vehicle immediately upon arrival at your destination. Always keep compressor level and never lie on its side.



⚠ WARNING: RISK FROM FLYING OBJECTS

WHAT CAN HAPPEN

- The compressed air stream can cause soft tissue damage to exposed skin and can propel dirt, chips, loose particles and small objects at high speed, resulting in property damage or personal injury.

HOW TO PREVENT IT

- Always wear certified safety equipment: ANSI Z87.1 eye protection (CAN/CSA Z94.3) with side shields when using the compressor.
- Never point any nozzle or sprayer toward any part of the body or at other people or animals.
- Always turn the compressor off and bleed pressure from the air hose and air tank before attempting maintenance, attaching tools or accessories.



⚠ WARNING: RISK OF HOT SURFACES

WHAT CAN HAPPEN

- Touching exposed metal such as the compressor head or outlet tubes, can result in serious burns.

HOW TO PREVENT IT

- Never touch any exposed metal parts on compressor during or immediately after operation. Compressor will remain hot for several minutes after operation
- Do not reach around protective shrouds or attempt maintenance until unit has been allowed to cool.



⚠ WARNING: RISK OF ELECTRICAL SHOCK

WHAT CAN HAPPEN

- Your compressor is powered by electricity. Like any other electrically powered device, if it is not used properly it may cause electric shock.

HOW TO PREVENT IT

- Never operate the compressor outdoors when it is raining or in wet conditions.
- Never operate compressor with protective covers removed or damaged.

- Repairs attempted by unqualified personnel can result in serious injury or death by electrocution.

- Any electrical wiring or repairs required on this product should be performed by authorized service center personnel in accordance with national and local electrical codes.

- **Electrical Grounding:** Failure to provide adequate grounding to this product could result in serious injury or death from electrocution. Refer to **Grounding Instructions** paragraph in the *Installation* section.

- Make certain that the electrical circuit to which the compressor is connected provides proper electrical grounding, correct voltage and adequate fuse protection.



⚠ WARNING: RISK OF UNSAFE OPERATION

WHAT CAN HAPPEN

- Unsafe operation of your air compressor could lead to serious injury or death to you or others.

HOW TO PREVENT IT

- Review and understand all instructions and warnings in this manual.
- Become familiar with the operation and controls of the air compressor.
- Keep operating area clear of all persons, pets, and obstacles.
- Keep children away from the air compressor at all times.
- Do not operate the product when fatigued or under the influence of alcohol or drugs. Stay alert at all times.
- Never defeat the safety features of this product.
- Equip area of operation with a fire extinguisher.
- Do not operate machine with missing, broken, or unauthorized parts.
- Never stand on the compressor.



⚠ WARNING: RISK FROM MOVING PARTS

WHAT CAN HAPPEN

- Moving parts such as the pulley, flywheel, and belt can cause serious injury if they come into contact with you or your clothing.
- Attempting to operate compressor with damaged or missing parts or attempting to repair compressor with protective shrouds removed can expose you to moving parts and can result in serious injury.

HOW TO PREVENT IT

- Never operate the compressor with guards or covers which are damaged or removed.
- Keep your hair, clothing and gloves away from moving parts. Loose clothes, jewelry or long hair can be caught in moving parts.
- Air vents may cover moving parts and should be avoided as well.
- Any repairs required on this product should be performed by a DEWALT factory service center or a DEWALT authorized service center.



⚠ WARNING: RISK OF INJURY FROM LIFTING

WHAT CAN HAPPEN

- Serious injury can result from attempting to lift too heavy an object.

HOW TO PREVENT IT

- The compressor is too heavy to be lifted by one person. Obtain assistance from others before lifting.



⚠ CAUTION: RISK FROM NOISE

WHAT CAN HAPPEN

- Under some conditions and duration of use, noise from this product may contribute to hearing loss.

HOW TO PREVENT IT

- Always wear certified safety equipment: ANSI S12.6 (S3.19) hearing protection.

SAVE THESE INSTRUCTIONS FOR FUTURE USE

Know Your Air Compressor

READ THIS OWNER'S MANUAL AND SAFETY RULES BEFORE OPERATING YOUR UNIT. Compare the illustrations with your unit to familiarize yourself with the location of various controls and adjustments. Save this manual for future reference.

FEATURES

AUTO (-) / OFF (O) SWITCH

Place this switch (B) in the AUTO (-) position to provide automatic power to the pressure switch and OFF(O) to remove power at the end of each use. NOTE: ALWAYS ensure the switch (B) is in the OFF (O) position before removing or replacing pressure switch cover.

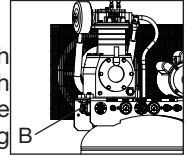

PRESSURE SWITCH

The pressure switch (B) automatically starts the motor when the air tank pressure drops below the factory set cut-in pressure. It stops the motor when the air tank pressure reaches the factory set cut-out pressure.

SAFETY VALVE

This valve (G) is designed to prevent system failures by relieving pressure from the system when the compressed air reaches a predetermined level. The valve is preset by the manufacturer and must not be removed or modified in any way.

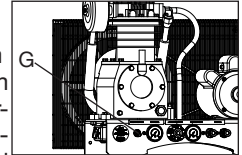

CHECK VALVE

When the air compressor is operating, the check valve (K) is open, allowing compressed air to enter the air tank. When the air compressor

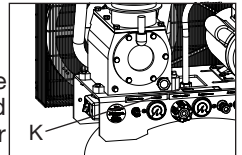

reaches cut-out pressure, the check valve closes, allowing air pressure to remain inside the air tank.

AIR INTAKE FILTER

The filter (A) is designed to clean air entering the pump. To ensure the pump continually receives a clean, cool, and dry air supply the filter must always be clean and the filter intake must be free from obstructions.

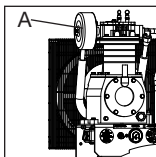

AIR TANK DRAIN VALVE

The drain valve (H) is located at the base of the air tank and is used to drain condensation at the end of each use. See *Draining Air Tank* under *Maintenance*.

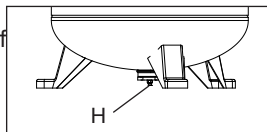

REGULATED PRESSURE GAUGE

The regulated pressure gauge (D) indicates the air pressure available at the outlet side of the regulator. This pressure is controlled by the regulator and is always less or equal to the air tank pressure.

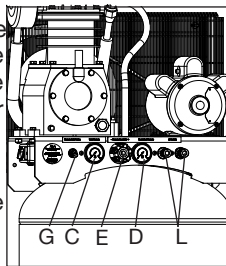

TANK PRESSURE GAUGE

The tank pressure gauge (C) indicates the reserve air pressure in the tank.

UNIVERSAL QUICK CONNECT BODY

The universal quick connect body (L) accepts the three most popular styles of quick connect plugs: Industrial, automotive, and ARO. One hand push-to-connect operation makes connections simple and easy.

REGULATOR

The regulator knob (E) controls the air pressure coming from the air tank.

To Adjust Regulator:

1. Pull regulator knob (E) out.
2. Turn knob clockwise to increase regulated pressure and counter-clockwise to decrease regulated pressure.
3. When desired pressure is shown on the regulated pressure gauge push knob in to lock.

⚠ WARNING: *Risk of Bursting. Too much air pressure causes a hazardous risk of bursting. Check the manufacturer's maximum pressure rating for air tools and accessories. The regulator outlet pressure must never exceed the maximum pressure rating.*

GLOBE VALVE/AIR DISCHARGE VALVE: (sold separately, not shown)

Opens and closes air distribution from compressor. See **Air Distribution System** paragraph under *Installation*.

REGULATOR (sold separately, not shown):

An air pressure regulator or a separate air transformer which combines the functions of air regulation and/or moisture and dirt removal is recommended for most applications. See **Air Distribution System** paragraph under *Installation*.

AIR COMPRESSOR PUMP

The pump compresses air into the air tank. Working air is not available until the compressor has raised the air tank pressure above that required at the air outlet.

MOTOR OVERLOAD PROTECTOR

The motor has a thermal overload protector. If the motor overheats for any reason, the overload protector will shut off the motor. The motor must be allowed to cool down before restarting. To restart:

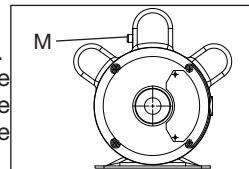

1. Set the Auto/Off switch to OFF (O).
2. Allow the motor to cool.
3. Depress the red reset button (M on the motor).
4. Set the Auto/Off switch to AUTO (-).

INSTALLATION

Assembly (Fig. 1)

Unpack the air compressor. Inspect the unit for damage. If the unit has been damaged in transit, contact the carrier and complete a damage claim. Do this immediately because there are time limitations to damage claims.

The carton should contain:

- air compressor
- operator and parts manuals

Check the compressor's serial label to ensure that you have received the model ordered, and that it has the required pressure rating for its intended use.

INSTALLING HOSES

⚠ WARNING: Risk of unsafe operation. Firmly grasp hose in hand when installing or disconnecting to prevent hose whip.

1. Ensure regulated pressure gauge reads 0 psi.
2. Apply sealant tape to hose threads.
3. Assemble hose to air outlet (F). **IMPORTANT:** Do not assemble splitters directly to the air outlet (F).

NOTE: Assembling quick connect bodies (L) to air outlet (F) and quick connect plugs to hose ends make connecting and disconnecting hoses simple and easy. Quick connect bodies and plugs are available for purchase from your local dealer or authorized service center.

DISCONNECTING HOSES

⚠ WARNING: Risk of unsafe operation. Firmly grasp hose in hand when installing or disconnecting to prevent hose whip.

1. Ensure regulated pressure gauge reads 0 psi.
2. Remove hose from air outlet (F).

Lubrication and Oil

AIR COMPRESSOR

The air compressor pump was filled **WITH** oil at the manufacturer. Check air compressor pump oil level before operating unit. See **Compressor Pump Oil** under *Maintenance*.

Compatibility

Air tools and accessories that are run off the compressor must be compatible with petroleum based products. If you suspect that a material is not compatible with petroleum products, an air line filter for removal of moisture and oil vapor in compressed air is required.

NOTE: Always use an air line filter to remove moisture and oil vapor when spraying paint.

Location

- Locate the air compressor in a clean, dry, and well ventilated area.
- Located the air compressor at least 12" (30.5 cm) away from the wall or other obstructions that will interfere with the flow of air.
- Locate the air compressor as close to the main power supply as possible to avoid using long lengths of electrical wiring. **NOTE:** Long lengths of electrical wiring could cause power loss to the motor.

- The air filter must be kept clear of obstructions which could reduce air flow to the air compressor.

HUMID AREAS

In frequently humid areas, moisture may form in the pump and produce sludge in the oil, causing running parts to wear out prematurely. Excessive moisture is especially likely to occur if the unit is located in an unheated area that is subject to large temperature changes. Two signs of excessive humidity are external condensation on the pump when it cools down and a “milky” appearance in compressor oil. You may be able to prevent moisture from forming in the pump by increasing ventilation or operating for longer intervals.

NOISE CONSIDERATIONS

Consult local officials for information regarding acceptable noise levels in your area. To reduce excessive noise, use vibration mounts or silencers, relocate the unit or construct total enclosures or baffle walls. Contact a DeWALT service center or call 1-888-895-4549 for assistance.

Anchoring of the Air Compressor

⚠ WARNING: Risk of bursting. Excessive vibration can weaken the air tank and cause an explosion. The compressor must be properly mounted.

The air compressor MUST be bolted to a level, solid concrete surface. Use 3/8” lag screws, vibration pads and concrete anchors. If help is needed anchoring the air compressor consult a licensed contractor.

1. Place the air compressor on a level, solid concrete surface. Make sure the concrete is in good condition with no cracks or damage.

2. Mark the surface using the holes in the air compressor feet as a template.
3. Drill holes in the surface for the concrete anchors. Install concrete anchors.
4. Line-up holes in surface with holes in air compressor feet.
5. Place the vibration pads (not supplied) between the floor and air compressor feet, see figure. If needed use shims to level the unit.
6. Place the 3/8” lag screws through the air compressor feet, vibration pads and into the anchors.
7. Torque 3/8” lag screws to 7-10 ft.-lbs (9.5-13.5 Nm).

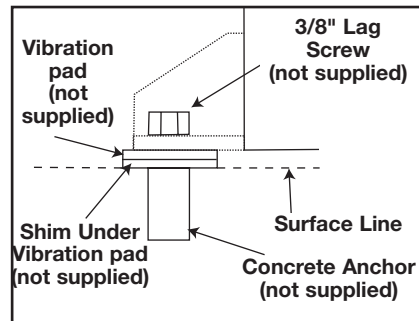

Wiring Instructions

⚠ WARNING: Improper electrical installation of this product may void its warranty and your fire insurance. Have circuit wiring performed by qualified personnel such as a licensed electrician who is familiar with the current national electrical code and any prevailing local electrical codes.

⚠ WARNING: Risk of electrical shock. Improper electrical grounding can result in electrical shock. The wiring should be done by a qualified electrician.

- A qualified electrician needs to know the following before wiring:
1. The amperage rating of the electrical box should be adequate.

Refer to the *Specifications*, in the parts manual, for this information.

- The supply line should have the same electrical characteristics (voltage, cycle, phase) as the motor. Refer to the motor nameplate, on side of motor, for this information.

NOTE: The wiring used must be rated for the motor nameplate voltage, plus or minus 10%. Refer to local codes for recommended wire sizes, correct wire size, and maximum wire run; undersize wire causes high amp draw and overheating to the motor.

▲ WARNING: *Risk of electrical shock. Electrical wiring must be located away from hot surfaces such as manifold assembly, compressor outlet tubes, heads, or cylinders.*

Grounding Instructions

This product should be connected to a metallic, permanent wiring system, of and equipment-grounding terminal or lead on the product.

Voltage and Circuit Protection

Refer to the Voltage and Minimum Branch Circuit Requirements under Specifications.

▲ CAUTION: *Certain air compressors can be operated on a 15 amp circuit if the following conditions are met.*

- Voltage supply to circuit must comply with the National Electrical Code.
- Circuit is not used to supply any other electrical needs.
- Extension cords comply with specifications.
- Circuit is equipped with a 15 amp circuit breaker or 15 amp time delay fuse. NOTE: If compressor is connected to a circuit protected by fuses, use only time delay fuses. Time delay fuses should be marked “D” in Canada and “T” in the U.S.

If any of the above conditions cannot be met, or if operation of the compressor repeatedly causes interruption of the power, it may be necessary to operate it from a 20 amp circuit. It is not necessary to change the cord set.

Main power disconnect switch

Install a main power disconnect switch in the line from the panel to the compressor. The main power disconnect switch must be located near the compressor, for ease of use and safety. When turned OFF, the main power disconnect switch shuts off all power to the compressor. When it is turned ON, the compressor will start and stop automatically, controlled by the pressure switch.

Air Distribution System

▲ WARNING: *Risk of bursting. Plastic or PVC pipe is not designed for use with compressed air. Regardless of its indicated pressure rating, plastic pipe can burst from air pressure. Use only metal pipe for air distribution lines.*

INSTALLING AND DISCONNECTING HOSES

▲ WARNING: *Risk of unsafe operation. Firmly grasp hose in hand when installing or disconnecting to prevent hose whip. Ensure regulated pressure gauge reads 0 psi.*

The next figure represents a typical air distribution system. The following are tips to remember when setting up the air compressor’s air distribution system.

NOTE: Compressed air from oil lube air compressors will contain water condensation and oil mist. Several drains, traps and filters will be needed to supply air without water (including aerosols) or oil to spray equipment, air tools and accessories requiring filtered air. Always read the instructions for the air tools and accessories being used.

- Use pipe that is the same size as the air tank outlet. Piping that is too small will restrict the flow of air.
- If piping is over 100' (30.5 m) long, use the next larger size.
- Bury underground lines below the frost line and avoid pockets where condensation can gather and freeze. Apply pressure before underground lines are covered to make sure all pipe joints are free of leaks.
- A flexible coupling is recommended to be installed between the globe valve/air discharge outlet and main air distribution line to allow for vibration.
- A separate regulator is recommended to control the air pressure. Air pressure from the tank is usually too high for individual air driven tools.
- DO NOT install lubricators between the tank and any spray equipment, air tool or accessory requiring oil-free filtered air.
- Drain all traps, filters and dirt legs daily.

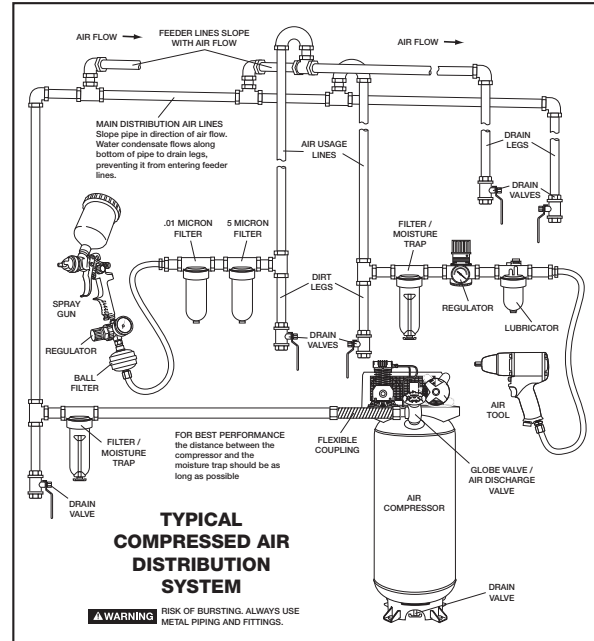

How to Use Your Unit (Fig 3)

How to Stop:

Set the Auto/Off switch to "Off".

Before Starting

WARNING: Do not operate this unit until you read this instruction

manual for safety, operation and maintenance instructions.

Break-in Procedure

NOTICE: Risk of property damage. Serious damage may result if the following break-in instructions are not closely followed.

This procedure is required **before** the air compressor is put into service and when the check valve or a complete compressor pump has been replaced.

1. Make sure the Auto/Off switch is in the “Off” position.
2. Check oil level in pump. See **Oil** paragraph in the *Maintenance* section for instructions.
3. Recheck all wiring. Make sure wires are secure at all terminals connections. Make sure all contacts move freely and are not obstructed.
4. Open the drain valve (counterclockwise) fully to permit air to escape and prevent air pressure build up in the air tank during the break-in period.
5. Move the Auto/Off switch to “Auto” position. The compressor will start.
6. Run the compressor for 30 minutes. Make sure the drain valve and all air lines are open so there is only a minimal air pressure build-up in tank.

NOTE: After about 30 minutes, If the unit does not operate properly, SHUT DOWN IMMEDIATELY, and contact Product Service.

7. Check all air line fittings and connections/piping for air leaks by applying a soap solution. Correct if necessary. **NOTE:** Minor leaks can cause the air compressor to overwork, resulting in premature breakdown or inadequate performance.
8. Check for excessive vibration. Readjust or shim air compressor feet, if necessary.

9. After 30 minutes, turn the Auto/Off switch to the “Off” position.
10. Close the drain valve.
11. Turn the Auto/Off switch to the “Auto” position. The air receiver will fill to “cut-out” pressure and the motor will stop.

The compressor is now ready for use.

Before Each Start-Up

1. Place Auto/Off switch to “Off”.
2. Close the drain valve.
3. Visually inspect air lines and fittings for leaks.
4. Check safety valve. See **To Check Safety Valve** under *Maintenance*.
5. Pull the regulator knob out and turn counterclockwise to set the outlet pressure to zero.
6. Attach hose and accessories.

▲ WARNING: Risk of unsafe operation. Firmly grasp air hose in hand when installing or disconnecting to prevent hose whip.

▲ WARNING: Risk of unsafe operation. Do not use damaged or worn accessories.

NOTE: A regulator MUST be installed when using accessories rated at less than 135 psi.

NOTE: The hose or accessory will require a quick connect plug if the air outlet is equipped with a quick connect socket.

▲ WARNING: Risk of bursting. Too much air pressure causes a hazardous risk of bursting. Check the manufacturer’s maximum pressure rating for air tools and accessories. The regulator outlet pressure must never exceed the maximum pressure rating.

▲ CAUTION: Risk of unsafe operation. Compressed air from the unit may contain water condensation and oil mist. Do not spray unfil-

tered air at an item that could be damaged by moisture. Some air tools and accessories may require filtered air. Read the instructions for the air tools and accessories.

How to Start

1. Turn the Auto/Off switch to “Auto” and allow tank pressure to build. Motor will stop when tank pressure reaches “cut-out” pressure.
2. Pull the regulator knob out and turn clockwise to increase pressure. When the desired pressure is reached push knob in to lock in place.

IMPORTANT: When using regulator and other accessories refer to the manufacturers instructions.

⚠ WARNING: Risk of bursting. If any unusual noise or vibration is noticed, stop the compressor immediately and have it checked by a trained service technician.

The compressor is ready for use.

Shut-down (Fig. 1)

1. Move Auto/Off switch to the OFF position. **NOTE:** If finished using compressor, follow Steps 2 - 6.
2. Pull the regulator knob out and turn counterclockwise until fully closed. Ensure regulated pressure gauge reads 0 psi. Push knob in to lock in place.
3. Remove hose and accessory.

⚠ WARNING: Risk of unsafe operation. Firmly grasp air hose in hand when installing or disconnecting to prevent hose whip.

4. Drain the air tank, see **Draining Air Tank** under *Maintenance*. Ensure air tank pressure gauge reads 0 psi.

⚠ WARNING: Risk of bursting. Drain air tank daily. Water will condense in air tank. If not drained, water will corrode and weaken

the air tank causing a risk of air tank rupture.

5. Allow the compressor to cool down.
6. Wipe air compressor clean and store in a safe, non-freezing area.

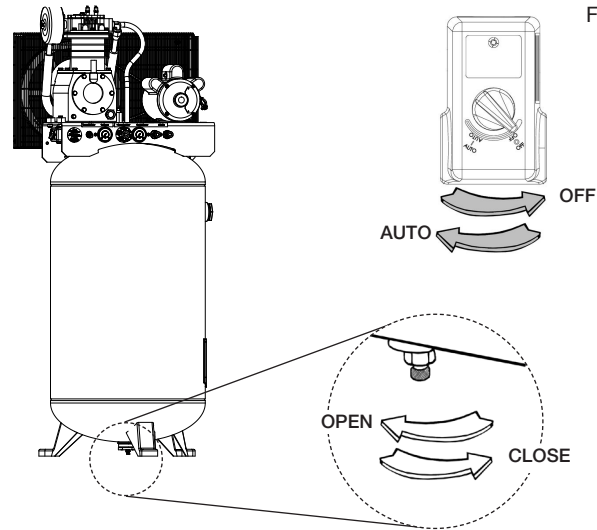

FIG. 3

MAINTENANCE

Maintenance Chart

Procedure	Daily	Weekly	Monthly	1 year or 200 Hours	See tank warning label
Check safety valve	X				
Inspect air filter		X ⁺			
Drain air tank	X				
Check pump oil level	X				
Change pump oil				X ^{***}	
Oil leak inspection	X				
Inspect drive belt	X				
Check drive belt tension			X		
Check pulley/flywheel alignment				X	
Check for unusual noise/vibration	X				
Check for air leaks	X [*]				
Clean compressor exterior		X			
Remove tank from service					X ⁺⁺
* To check for air leaks apply a solution of soapy water around joints. While compressor is pumping to pressure and after pressure cuts out, look for air bubbles to form.					
** The pump oil must be changed after the first 20 hours of operation. Thereafter, when using synthetic blend non-detergent air compressor oil, change oil every 200 hours of operation or once a year, whichever comes first.					
+ Perform more frequent in dusty or humid conditions.					
** For more information, call 1-888-895-4549 .					

⚠ WARNING: Risk of unsafe operation. Unit cycles automati-

cally when power is on. When performing maintenance, you may be exposed to voltage sources, compressed air, or moving parts. Personal injuries can occur. Before performing any maintenance or repair, disconnect power source from the compressor and bleed off all air pressure.

To ensure efficient operation and longer life of the air compressor outfit, a routine maintenance schedule should be prepared and followed. The following routine maintenance schedule is geared to an outfit in a normal working environment operating on a daily basis. If necessary, the schedule should be modified to suit the conditions under which your compressor is used. The modifications will depend upon the hours of operation and the working environment. Compressor outfits in an extremely dirty and/or hostile environment will require a greater frequency of all maintenance checks.

NOTE: See Operation section for the location of controls.

Checking Safety Valve (Fig. 1)

⚠ WARNING: Hot surfaces. Risk of burn. Tubes, pump head, and surrounding parts are very hot, do not touch (see the Hot Surfaces identified in Fig. 2). Allow compressor to cool prior to servicing.

⚠ WARNING: Risk of bursting. If the safety valve does not work properly, over-pressurization may occur, causing air tank rupture or an explosion.

⚠ WARNING: Risk from flying objects. Always wear certified safety equipment: ANSI Z87.1 eye protection (CAN/CSA Z94.3) with side shields.

Before starting compressor, pull the ring on the safety valve to make sure that the safety valve operates freely. If the valve is stuck or does not operate smoothly, it must be replaced with the same type of valve.

Checking Air Filter (Fig. 1)

⚠ WARNING: Hot surfaces. Risk of burn. Tubes, pump head, and surrounding parts are very hot, do not touch (see the Hot Surfaces identified in Fig. 2). Allow compressor to cool prior to servicing.

A dirty air filter will not allow the compressor to operate at full capacity. Keep the air filter clean at all times.

1. Ensure Auto/Off switch (B) is in the OFF Position.
2. Allow unit to cool.
3. Remove the wing nut (N).
4. Remove the outer metal cover (O).
5. Check the filter element (P) if it is dirty or filled with paint, replace it.
6. Place the outer metal cover back over the filter element.
7. Secure with the wing nut.

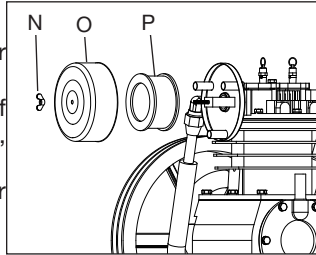

⚠ CAUTION: Risk of unsafe operation. Do not operate without air filter.

Draining Air Tank (Fig. 3)

⚠ WARNING: Risk of unsafe operation. Air tanks contain high pressure air. Keep face and other body parts away from outlet of drain. Use eye protection [ANSI Z87.1 (CAN/CSA Z94.3)] when draining as debris can be kicked up into face.

⚠ WARNING: Risk from noise. Use ear protection (ANSI S12.6 (S3.19) as air flow noise is loud when draining.

NOTE: All compressed air systems generate condensation that accumulates in any drain point (e.g., tanks, filter, aftercoolers, dryers). This

condensate contains lubricating oil and/or substances which may be regulated and must be disposed of in accordance with local, state, and federal laws and regulations.

1. Set the Auto/Off switch to “Off”.
2. Pull the regulator knob out and turn counterclockwise to set the outlet pressure to zero.
3. Remove the air tool or accessory.
4. Pull ring on safety valve allowing air to bleed from the tank until tank pressure is approximately 20 psi. Release safety valve ring.
5. Drain water from air tank by opening drain valve (counterclockwise) on bottom of tank.

⚠ WARNING: Risk of bursting. Water will condense in the air tank. If not drained, water will corrode and weaken the air tank causing a risk of air tank rupture.

NOTICE: Risk of property damage. Drain water from air tank may contain oil and rust which can cause stains.

6. After the water has been drained, close the drain valve (clockwise). The air compressor can now be stored.

NOTE: If drain valve is plugged, release all air pressure. The valve can then be removed, cleaned, then reinstalled.

Compressor Pump Oil (Fig. 4)

NOTICE: Risk of property damage. Use air compressor oil only. Multi-weight automotive engine oils like 10W30 should not be used in air compressors. They leave carbon deposits on critical components, thus reducing performance and compressor life.

NOTE: Use synthetic blend non-detergent air compressor oil.

NOTE: Crankcase oil capacity is approximately 18.5 fluid ounces (547 ml).

Checking

1. The oil level should be to the middle of the sight glass (S).
2. If needed remove oil fill plug (Q) and slowly add oil until it reaches the middle of the sight glass.

Changing

⚠ WARNING: Drain tank to release air pressure before removing the oil fill cap or oil drain plug.

1. Remove the oil fill plug (Q).
2. Remove the oil drain plug (R) and drain oil into a suitable container.
3. Replace the oil drain plug (R) and tighten securely
4. Slowly add compressor oil until it reaches the middle of the sight glass (S). **NOTE:** When filling the crankcase, the oil flows very slowly into the pump. If the oil is added too quickly, it will overflow and appear to be full.

⚠ CAUTION: Overfilling with oil will cause premature compressor failure. Do not overfill.

5. Replace oil fill plug (Q) and tighten securely.

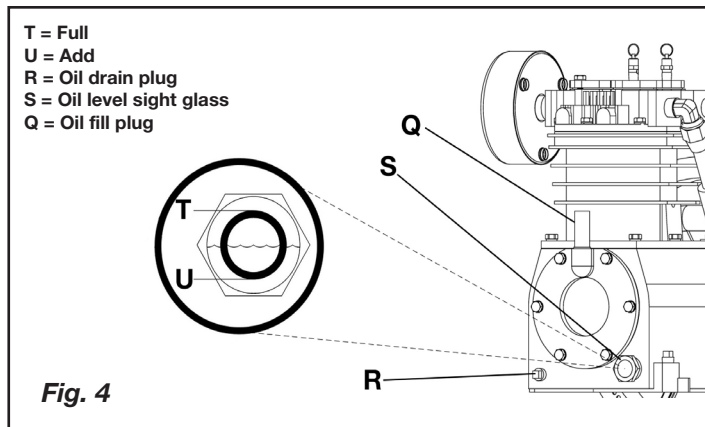

Belt Replacement

⚠ WARNING: This unit starts automatically. ALWAYS shut off the main power disconnect, and bleed all pressure from the system before servicing the compressor, and when the compressor is not in use. Do not use the unit with the shrouds or belt guard removed. Serious injury could occur from contact with moving parts. Hot surfaces. Risk of burn. Pump head, and surrounding parts are very hot, do not touch (see the Hot Surfaces identified in Fig. 2). Allow compressor to cool prior to servicing.

1. Set the Auto/Off lever to “Off”, shut off the main power disconnect, and relieve all air pressure from the air tank.
2. Remove the belt guard by turning the 4 belt guard clips (V) 1/4 turn using a 5/8” wrench.
3. Mark pump position on saddle.

4. Loosen the motor mounting screws and slide the motor toward the air compressor.
5. Remove the belt and replace with a new one.
6. See the **Adjusting Belt Tension** before tightening motor mounting screws.

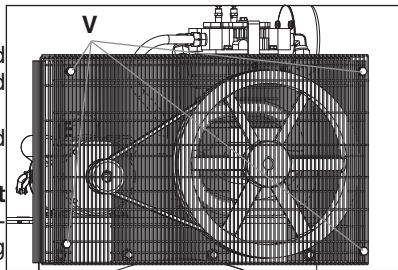

Adjusting Belt Tension

1. Slide motor into original position, line the motor up with the mark made earlier on saddle.
2. Tighten two outside motor mounting screws enough to hold the motor in place for checking pulley and flywheel alignment.
3. The belt should deflect $1/2$ " (13 mm) at midway between the pulley and the flywheel when a 10 pound (4.6 kg.) weight is applied at the midway point.
3. When proper belt tension is achieved, tighten all four motor mounting screws. Torque to 20-25 ft-lbs (27.1–33.9 Nm).

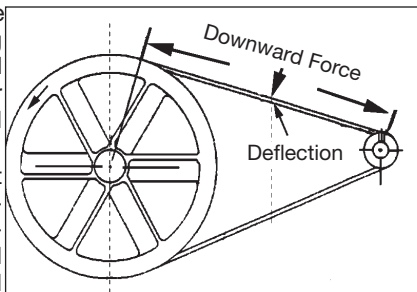

NOTE: Once the engine pulley has been moved from its factory set location, the grooves of the flywheel and pulley must be aligned

to within $1/16$ " (1.6 mm) to prevent excessive belt wear. Verify the alignment by performing the following **Motor Pulley/Flywheel Alignment**.

Motor Pulley/Flywheel Alignment

NOTE: Once the motor pulley has been moved from its factory set location, the grooves of the flywheel and pulley must be aligned to within $1/16$ " (1.6 mm) to prevent excessive belt wear.

The air compressor flywheel and motor pulley must be in-line (in the same plane) within $1/16$ " (1.6 mm) to assure belt retention within flywheel belt grooves. To check alignment, perform the following steps:

1. Set the Auto/Off lever to "Off", shut off the main power disconnect, and relieve all air pressure from the air tank.
2. Remove belt guard.
3. Place a straightedge against the outside of the flywheel and the motor drive pulley.
4. Measure the distance between the edge of the belt and the straightedge at points A1 and A2 in figure. The difference between measurements should be no more than $1/16$ " (1.6 mm).
5. If the difference is greater than $1/16$ " (1.6 mm) loosen the set screw holding the motor drive pulley to the shaft and adjust the pulley's position on the shaft until the A1 and A2 measurements are within $1/16$ " (1.6 mm) of each other.
6. Tighten the motor drive pulley set screw.
7. Visually inspect the motor drive pulley to verify that it is perpendicular to the drive motor shaft. Points B1 and B2 of Figure should appear to be equal. If they are not, loosen the setscrew

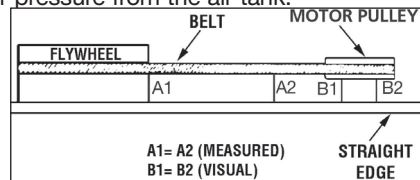

of the motor drive pulley and equalize B1 and B2, using care not to disturb the belt alignment performed in step 2.

8. Retighten the motor drive pulley setscrew. Torque to 145–165 in/lbs (16.4–20.3 Nm).
9. Reinstall belt guard.

Air Compressor Pump Intake and Exhaust Valves

Once a year have a Trained Service Technician check the air compressor pump intake and exhaust valves.

Inspect Air Lines and Fittings for Leaks

1. Set the Auto/Off lever to “Off”, shut off the main power disconnect, and relieve all air pressure from the air tank.
2. Apply a soap solution to all air line fittings and connections/piping.
3. Correct any leaks found.

IMPORTANT: Even minor leaks can cause the air compressor to overwork, resulting in premature breakdown or inadequate performance.

Air compressor Head Bolts - Torquing

The air compressor pump head bolts should be kept properly torqued. Check the torques of the head bolts after the first five hours of operation. Torque to 14-16 ft.-lbs. (18.9–21.7 Nm).

Service and Adjustments

ALL MAINTENANCE AND REPAIR OPERATIONS NOT LISTED MUST BE PERFORMED BY TRAINED SERVICE TECHNICIAN.

⚠ WARNING: Risk of unsafe operation. Unit cycles automatically when power is on. When servicing, you may be exposed

to voltage sources, compressed air, or moving parts. Before servicing unit unplug or disconnect electrical supply to the air compressor, bleed tank of pressure, and allow the air compressor to cool.

To Replace or Clean Check Valve

1. Release all air pressure from air tank. See **Draining Air Tank** in the *Maintenance* section.
2. Set the Auto/Off lever to “Off”, shut off the main power disconnect, and relieve all air pressure from the air tank.

3. Using an adjustable wrench loosen outlet tube nut at air tank and pump. Carefully move outlet tube away from check valve.
4. Using an adjustable wrench loosen pressure relief tube nut at air tank. Carefully move pressure relief tube away from check valve.

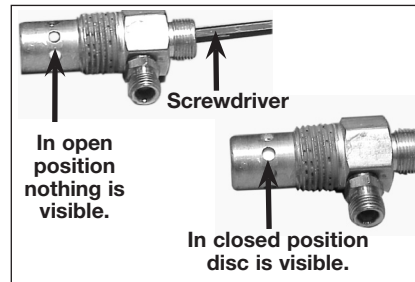

5. Unscrew the check valve (turn counterclockwise) using a 7/8” open end wrench. **NOTE** the orientation for reassembly.
6. Using a screwdriver, carefully push the valve disc up and down. **NOTE:** The valve disc should move freely up and down on a spring which holds the valve disc in the closed position, if not the check valve needs to be cleaned or replaced.
7. Clean or replace the check valve. A solvent, such as paint or varnish remover can be used to clean the check valve.
8. Apply sealant to the check valve threads. Reinstall the check valve (turn clockwise).

9. Replace the pressure release tube. Tighten nuts.
10. Replace the outlet tube and tighten nuts.
11. Perform the Break-in Procedure. See **Break-in Procedure** in the *Operation* section.

Additional Service

Disassembly or service of the air compressor beyond what is covered in this manual is not recommended. If additional service is required, contact your nearest Authorized Warranty Service Center.

Accessories

Recommended accessories for use with your tool are available for purchase from your local dealer or authorized service center. If you need assistance in locating any accessory for your tool, please call 1-888-895-4549 or visit our website www.dewalt.com.

▲ WARNING: The use of any other accessory not recommended for use with this tool could be hazardous. Use only accessories rated equal to or higher than the rating of the air compressor.

Service Information

Please have the following information available for all service calls:
 Model Number _____ Serial Number _____
 Date and Place of Purchase _____

Repairs

To assure product SAFETY and RELIABILITY, repairs, maintenance and adjustment should be performed by a DEWALT factory service center, a DEWALT authorized service center or other qualified service personnel. Always use identical replacement parts.

Limited Warranty

DEWALT Industrial Tools are warranted from date of purchase.

2 Year – Limited warranty on oil-lubricated air compressor pumps.

1 Year – Limited warranty on all other air compressor components. This warranty is not transferable to subsequent owners.

DEWALT will repair or replace, without charge, at DEWALT's option, any defects due to faulty materials or workmanship. For further detail of warranty coverage and warranty repair information, call 1-(888)-895-4549 or visit dewalt.com. This warranty does not apply to accessories or damage caused where repairs have been made or attempted by others. This warranty also does not apply to merchandise sold by DEWALT which has been manufactured by and identified as the product of another company, such as gasoline engines. Such manufacturer's warranty, if any, will apply. **ANY INCIDENTAL, INDIRECT OR CONSEQUENTIAL LOSS, DAMAGE OR EXPENSE THAT MAY RESULT FROM ANY DEFECT, FAILURE OR MALFUNCTION OF THE PRODUCT IS NOT COVERED BY THIS WARRANTY.** Some states do not allow the exclusion of limitation of incidental or consequential damages, so the above limitation or exclusion may not apply to you. **IMPLIED WARRANTIES, INCLUDING THOSE OF MERCHANTABILITY OR FITNESS FOR A PARTICULAR PURPOSE, ARE LIMITED TO ONE YEAR FROM THE DATE OF ORIGINAL PURCHASE.** Some states do not allow limitations on how long an implied warranty lasts, so the above limitations may not apply to you.

What the Company Will Do: (the company) will cover parts and labor to remedy substantial defects due to materials

and workmanship during the first year of ownership, with the exceptions noted below. Parts used in repair of whole goods or accessories are warranted for the balance of the original warranty period.

What is not covered Under This Warranty? Failures by the original retail purchaser to install, maintain, and operate said equipment in accordance with standard industry practices. Modifications to the product, or tampering with components, or failure to comply with the specific recommendations of the Company set forth in the owner's manual, will render this warranty null and void. The Company shall not be liable for any repairs, replacements, or adjustments to the equipment, or any costs for labor performed by the purchaser without the Company's prior written approval. The effects of corrosion, erosion, surrounding environmental conditions, cosmetic defects, and routine maintenance items, are specifically excluded from this warranty. Routine maintenance items such as: oil, lubricants, and air filters, as well as changing oil, air filters, belt tensioning, etc... fall under the owner's responsibility. Additional exclusions include: freight damage, failures resulting from neglect, accident, or abuse, induction motors when operated from a generator, oil leaks, air leaks, oil consumption, leaky fittings, hoses, petcocks, bleeder tubes, and transfer tubes.

- The following components are considered normal wear items and are not covered after the first year of ownership: Belts, sheaves, flywheels, check valves, pressure switches, air unloaders, throttle controls, electric motors, brushes, regulators, o-rings, pressure gauges, tubing, piping, fittings, fasteners, wheels, quick couplers, gaskets, seals, air filter housings, piston rings, connecting rods, and piston seals.

- Labor, service calls, and travel charges, are not covered after the first year of ownership on stationary compressors (compressors without handles, or wheels). Repairs requiring overtime, weekend rates, or any other charges beyond the standard shop labor rate are not covered.
- Time required for orientation training for the service center to gain access to the product, or additional time due to inadequate egress.
- Damage caused by incorrect voltage, improperly wired, or failure to have a certified licensed electrician install the compressor, will render this warranty null and void.
- Damage caused from inadequate filter maintenance.
- Pump wear or valve damage caused by using oil not specified.
- Pump wear or damage caused by any oil contamination.
- Pump wear or valve damage caused by failure to follow proper maintenance guidelines.
- Operation below proper oil level or operation without oil.
- Gas Engines, if product is equipped with a gas engine, see engine manual for specific engine manufacturer's warranty coverage.

Parts purchased separately: The warranty for parts purchased separately such as: pumps, motors, etc., are as follows:

From Date of Purchase

- | | |
|--------------------------------|---------|
| • All single & two stage pumps | 1 year |
| • Electric motors | 90 days |
| • Universal motor/pump | 30 days |

- All other parts 30 days
- No return authorization will be issued for electrical components once items are installed.

How do You Get Service? In order to be eligible for service under this warranty you must be the original retail purchaser, and provide proof of purchase from one of the Company's dealers, distributors, or retail outlet stores. Portable compressors or components must be delivered, or shipped, to the nearest Authorized Service Center. All associated freight costs and travel charges must be borne by the consumer. Please call our toll free number 1-888-895-4549 for assistance.

THIS WARRANTY GIVES YOU SPECIFIC LEGAL RIGHTS, AND YOU MAY ALSO HAVE OTHER RIGHTS WHICH VARY FROM STATE TO STATE.

THE COMPANY MAKES NO OTHER WARRANTY OR REPRESENTATION OF ANY KIND WHATSOEVER, EXPRESSED OR IMPLIED, EXCEPT THAT OF TITLE. ALL IMPLIED WARRANTIES, INCLUDING ANY WARRANTY OF MERCHANTABILITY AND FITNESS FOR PARTICULAR PURPOSE ARE HEREBY DISCLAIMED. LIABILITY FOR CONSEQUENTIAL AND INCIDENTAL DAMAGES UNDER ANY AND ALL WARRANTIES, OTHER CONTRACTS, NEGLIGENCE, OR OTHER TORTS IS EXCLUDED TO THE EXTENT EXCLUSION IS PERMITTED BY LAW.

FREE WARNING LABEL REPLACEMENT: If your warning labels become illegible or are missing, call 1-888-895-4549 for a free replacement.

<p>▲ WARNING ADVERTISSEMENT ADVERTENCIA</p>	<p>HOT SURFACES: To reduce the risk of burns - Do not touch exposed metal surfaces.</p> <p>SURFACES CHAUDES: Pour réduire le risque de brûlures - Ne pas toucher les surfaces métalliques exposées.</p> <p>SUPERFICIES CALIENTES: Para reducir el riesgo de sufrir quemaduras - No tocar las superficies metálicas expuestas.</p>	 <p>098-304</p>
<p>▲ WARNING ADVERTISSEMENT ADVERTENCIA</p> <p>Before starting, read and understand the operator manual for safe operation and maintenance.</p> <p>Risk of fire or explosion: Do not spray a flammable liquid in a confined area or towards a hot surface. Spray area must be well ventilated. Do not smoke while spraying or spray where spark or flame is present. * Adding parts—Keep compressor at least 20 feet away from explosive vapors, such as when spraying with a spray gun.</p> <p>Risk of electric shock: Do not expose to rain. Store indoors. Use a dedicated circuit. If connected to a circuit protected by a fuse, use time delay marked (D).</p>	<p>▲ AVERTISSEMENT ADVERTISSEMENT ADVERTENCIA</p> <p>Avant de commencer, prenez le temps de bien comprendre le manuel de l'opérateur pour une utilisation sécuritaire.</p> <p>Risque d'incendie ou d'explosion: Ne pas pulvériser de liquide inflammable dans un endroit confiné ou vers une surface chaude. La zone de pulvérisation doit être correctement ventilée. * Ne pas fumer pendant la pulvérisation et ne jamais fumer en présence d'éclaboussures ou de flammes. * Placer le véhicule - Installez le compresseur à au moins 6 mètres (20 pi) des vapeurs explosives comme lors de l'application de peinture au pistolet.</p> <p>Risque de choc électrique: Ne pas exposer à la pluie. Garder à l'intérieur. Utiliser un circuit dédié. Si l'équipement est connecté à un circuit protégé par fusibles, employer des fusibles de marque D.</p>	<p>▲ ADVERTENCIA ADVERTENCIA ADVERTENCIA</p> <p>Antes de comenzar, lee y entienda el manual del operador para operar y dar mantenimiento a la unidad de manera segura.</p> <p>Riesgo de incendio o explosión: No rocíe líquidos inflamables en áreas confinadas ni hacia superficies calientes. El área donde se va a rociar deberá estar bien ventilada. * No fume mientras rocía, ni rocíe en presencia de chispas o flamas. * Puestas que pueden producir arco: Mantenga el compresor al menos a 6 metros (20 pies) de distancia de vapores explosivos, como los que se forman cuando se usa una pistola rociadora.</p> <p>Riesgo de descarga eléctrica: No exponga a la lluvia. Almacene en el interior. Utilice un circuito dedicado. Si se conecta a un circuito protegido con fusibles, utilice fusibles con retardo marcado (D) en este producto.</p>
<p>▲ WARNING ADVERTISSEMENT ADVERTENCIA</p> <p>Risk of burning—Do not adjust regulator to result in output pressure greater than the marked maximum pressure of attachment. If a regulator has not been installed, use only attachments rated at 200 psi or higher. * Rust weakens tank, may cause explosion and severe fire/explosion injury damage. Drain condensed water from tank after each use to reduce rusting. * Never weld on or repair tank—replace by authorized dealer.</p>	<p>▲ AVERTISSEMENT ADVERTISSEMENT ADVERTENCIA</p> <p>Risque d'éclaboussure: Ne pas régler le régulateur à une pression de sortie supérieure à la pression maximale des accessoires. Si aucun régulateur n'est installé, utiliser que des accessoires d'une capacité nominale de 200 psi ou plus. * Une réservoir affaibli par la rouille peuvent exploser et entraîner la mort ou de graves blessures et provoquer d'importants dommages. Vidanger l'eau de condensation du réservoir après chaque utilisation afin de réduire la corrosion. * Ne jamais souder ni réparer le réservoir - faire remplacer ou changer un centre de service agréé.</p>	<p>▲ ADVERTENCIA ADVERTENCIA ADVERTENCIA</p> <p>Riesgo de explosión: No ajuste el regulador de manera que la presión de salida sea mayor que la presión máxima marcada del accesorio. Si se ha instalado un regulador, use solamente accesorios con presión nominal de 200 psi o más. * La corrosión debilita el tanque, puede causar una explosión y daños materiales graves e lesiones graves o fatales. Drene el agua condensada del tanque después de cada uso para reducir la corrosión. * Nunca soldar ni repare un tanque, reemplácelo o cambie en un centro de servicio autorizado.</p>
<p>▲ WARNING ADVERTISSEMENT ADVERTENCIA</p> <p>Risk of injury—Do not direct air stream at body. * Disconnect power and drain all pressure from tank before servicing and after each use. * Do not use until approved as fit for breathing. * Wear ANSI Z87 approved eye protection. * Do not operate with supplied guards removed.</p>	<p>▲ AVERTISSEMENT ADVERTISSEMENT ADVERTENCIA</p> <p>Risque de blessure: Ne jamais diriger le jet d'air vers le corps. * Déconnecter l'alimentation électrique et chasser toute pression d'air du réservoir avant l'entretien et après chaque usage. Ne pas utiliser jusqu'à ce qu'il soit approuvé pour respirer. * Porter des lunettes protectrices homologuées ANSI Z87. * Ne pas faire fonctionner si les dispositifs protecteurs sont enlevés.</p>	<p>▲ ADVERTENCIA ADVERTENCIA ADVERTENCIA</p> <p>Riesgo de lesión: No dirija la corriente de aire hacia el cuerpo. * Desconecte la corriente y libere toda la presión de aire del tanque antes de dar mantenimiento o después de cada uso. * No use hasta que sea aprobado para respirar. * Use protección ocular aprobada según ANSI Z87. * No opere sin los dispositivos de protección apropiados.</p>
<p>RISK OF BURSTING Moisture Drain</p> 	<p>RISQUE DE DÉTACHEMENT ÉVACUATO N D'EAU</p> 	<p>RISGO DE EXPLOSIÓN DESGASE DE AGUA</p> 

▲ WARNING
For supply connection, use wires acceptable for at least 90°C.

▲ AVERTISSEMENT
Pour la connexion d'alimentation, utilisez des fils pouvant supporter au moins 90°C.

▲ ADVERTENCIA
La conexión del suministro debe efectuarse con cables homologados para una temperatura de 90°C o mayor.

CAUTION
ATTENTION
PRECAUTION

To provide proper cooling the compressor must be kept a minimum of 12" (twelve inches) from the nearest wall or obstruction.

Afin d'assurer un refroidissement adéquat, le compresseur doit être situé à au moins 30 cm de tout mur ou obstacle.

Para que la compresora tenga un enfriamiento apropiado, debe mantenerse a una distancia mínima de 30 cm de la pared u obstrucción más cercana.

098-3031

Troubleshooting Guide

This section provides a list of the more frequently encountered malfunctions, their causes and corrective actions. The operator or maintenance personnel can perform some corrective actions, and others may require the assistance of a qualified DEWALT technician or your dealer.

Air leaks	1
Air leaks in air tank or at air tank welds	2
Air leaks between head and valve plate.....	3
Air leaks from safety valve.....	4
Compressor is not supplying enough air to operate accessories	1, 5, 6, 7, 9, 10
Restricted air intake.....	9
Oil in discharge air.....	9, 19, 31
Knocking Noise	4, 10, 11, 12, 13, 14
Excessive belt wear.....	10, 11, 14, 15
Squealing sound.....	10
Moisture in pump crankcase	1, 3, 8, 17, 18, 19, 20, 21, 22
Excessive current draw	14, 26, 27
Compressor won't start in cold temperatures	17, 34, 35
Pressure reading on the regulated pressure gauge drops when an accessory is used.....	23
Regulator knob has continuous air leak.....	24
Regulator will not shut off air outlet	24
Air tank pressure will not build	25
Compressor stalls.....	28, 29, 30
Overheating	27, 32, 33

Troubleshooting Codes

CODE	POSSIBLE CAUSE	POSSIBLE SOLUTION
1	Fittings are not tight	Tighten fittings where air can be heard escaping. Check fittings with soapy water solution. DO NOT OVERTIGHTEN.
2	Defective air tank	Air tank must be replaced. Do not repair the leak. ▲ WARNING: Risk of bursting. Do not drill into, weld or otherwise modify air tank or it will weaken. The air tank can rupture or explode.
3	Leaking seals	Contact a DEWALT factory service center or a DEWALT authorized service center.
4	Defective safety valve	Operate safety valve manually by pulling on ring. If valve still leaks, it must be replaced.
5	Prolonged excessive use of air	Decrease amount of air usage.
6	Compressor is not large enough for accessory	Check the accessory air requirement. If it is higher than the SCFM or pressure supplied by your air compressor, a larger compressor is needed to operate accessory.
7	Hole in air hose	Check and replace air hose, if required.
8	Unit operating in damp or humid conditions	Move unit to a dry well ventilated area.
9	Restricted air intake filter	Clean or replace air intake filter.
10	Loose belt	Check belt tension, see Adjusting Belt Tension under <i>Maintenance</i> .
11	Loose pulley	Tighten pulley set screw, torque to 85-90 in.-lbs. (9.6–10.2 Nm).
12	Loose flywheel	Tighten flywheel screw, torque to 14–18 ft.-lbs. (20.0–24.4 Nm).

CODE	POSSIBLE CAUSE	POSSIBLE SOLUTION
13	Carbon build-up in pump	Contact a DEWALT factory service center or a DEWALT authorized service center.
14	Belt to tight	Check belt tension, see Adjusting Belt Tension under <i>Maintenance</i> .
15	Pulley misalignment	See Motor Pulley/Flywheel Alignment under <i>Maintenance</i> .
16	Pump oil is low	Add synthetic blend, non-detergent air compressor oil to pump. See Compressor Pump Oil under <i>Maintenance</i> .
17	Detergent type oil being used in pump	Drain oil and refill pump with synthetic blend non-detergent air compressor oil.
18	Extremely light duty cycles	Run unit for longer duty cycles. It is recommended to run at high throttle 50-75% of the run time and idle for 25% of the run time.
19	Piston rings damaged or worn	Contact a DEWALT factory service center or a DEWALT authorized service center.
20	Cylinder or piston damaged or worn	Contact a DEWALT factory service center or a DEWALT authorized service center.
21	Compressor cylinder finish worn	Contact a DEWALT factory service center or a DEWALT authorized service center.
22	Water in pump oil	Drain oil and refill pump with synthetic blend non-detergent air compressor oil.
23	Regulator is not adjusted correctly for accessory being used.	It is normal for some pressure drop to occur when an accessory is used, adjust the regulator as instructed in Regulator under Features if pressure drop is excessive. NOTE: Adjust the regulated pressure under flow conditions while the accessory is being used.

CODE	POSSIBLE CAUSE	POSSIBLE SOLUTION
24	Damaged regulator	Replace
25	Regulator open	Roate the regulator knob counter-clockwise to its built-in stop and push knob in to lock in place.
26	Low voltage/motor overload	Check that power supply is adequate and that compressor is on a dedicated circuit. If using extension cord, try using without. If compressor is connected to a circuit protected by a fuse, use dual element time delay fuses (Buss Fusetron type "T" only).
27	Restricted air passages	Inspect and replace transfer tubes or check valve, as required.
28	Low voltage motor	Furnish adequate powder.
29	Bad check valve	Replace check valve.
30	Seized pump	Contact a DEWALT factory service center or a DEWALT authorized service center.
31	Oil level too high	Reduce to proper level. See Compressor Pump Oil under <i>Maintenance</i> .
32	Poor ventilation	Relocate compressor to an area with cool, dry, well circulated air, at least 12 in. from nearest wall.
33	Dirty cooling surfaces	Clean all cooling surfaces thoroughly.
34	Too much back pressure in tank.	Open drain valve when starting motor.
35	Compressor too cold	Move compressor to a warmer location.

GLOSSARY

CFM: Cubic feet per minute.

SCFM: Standard cubic feet per minute; a unit of measure of air delivery.

PSI: Pounds per square inch; a unit of measure of pressure.

Cut-in pressure: Factory set low pressure point that starts the compressor to repressurize the tank to a higher pressure.

Cut-out pressure: Factory set high pressure point that stops the compressor from increasing the pressure in the tank above a certain level.

Well-ventilated: A means of providing fresh air in exchange for dangerous exhaust or vapors.

Dedicated circuit: An electrical circuit reserved for the exclusive use of the air compressor.

ASME: American Society of Mechanical Engineers. Indicates that the components are manufactured, tested and inspected to the specifications set by ASME.

CSA: Canadian Standards Association

 Indicates that the products that have this marking have been manufactured, tested and inspected to standards that are set by CSA.

Canadian Standards Association (USA): Indicates that the products that have this marking have been

 manufactured, tested and inspected to standards that are set by CSA. These products also conform to U.L. standard 1450.

California Code: Unit may comply with California Code 462 (I) (2)/ (M) (2). Specification/model label is on the side of the air tank on units that comply with California Code.

NOTES