



P/N 850014 Rev. U 01/2011

This manual is one of a set of two supporting this product. Refer to P/N 875014M for Care and Operation Instructions.

Ce manuel est disponible en français, simplement en faire la demande. Numéro de la pièce 850014CF.

INSTALLATION INSTRUCTIONS

**MPD Direct-Vent
Gas Fireplaces**

**MERIT™ Plus
SERIES**

MODELS

MILLIVOLT:

MPDT-3328CNM-B	MPD-4035CNM-B
MPDT-3328CPM-B	MPD-4035CPM-B
MPDR-3328CNM-B	MPD-4540CNM-B
MPDR-3328CPM-B	MPD-4540CPM-B
MPD-3530CNM-B	
MPD-3530CPM-B	

ELECTRONIC:

MPDT-3328CNE-B	MPD-4035CNE-B
MPDT-3328CPE-B	MPD-4035CPE-B
MPDR-3328CNE-B	MPD-4540CNE-B
MPDR-3328CPE-B	MPD-4540CPE-B
MPD-3530CNE-B	
MPD-3530CPE-B	



OTL Report No. 116-F-13-4

This appliance may be installed in an aftermarket permanently located, manufactured home (USA only) or mobile home, where not prohibited by local codes. This appliance is only for use with the type of gas indicated on the rating plate. This appliance is not convertible for use with other gases, unless a certified kit is used.

⚠ WARNING / AVERTISSEMENT / AVISO

- HOT GLASS WILL CAUSE BURNS.
- DO NOT TOUCH GLASS UNTIL COOLED.
- NEVER ALLOW CHILDREN TO TOUCH GLASS.



- UNE SURFACE VITRÉE CHAUDE PEUT CAUSER DES BRÛLURES.
- LAISSER REFROIDIR LA SURFACE VITRÉE AVANT D'Y TOUCHER.
- NE PERMETTEZ JAMAIS À UN ENFANT DE TOUCHER LA SURFACE VITRÉE.

- EL VIDRIO CALIENTE CAUSARÁ QUEMADURAS.
- USTED DEBE NUNCA TOCAR EL VIDRIO CALIENTE.
- LOS NIÑOS DEBEN NUNCA TOCAR EL VIDRIO.

WARNING: If the information in these instructions is not followed exactly, a fire or explosion may result, causing property damage, personal injury, or death.

- Do not store or use gasoline or other flammable vapors and liquids in the vicinity of this or any other appliance.
- **WHAT TO DO IF YOU SMELL GAS:**
 - Do not try to light any appliance.
 - Do not touch any electrical switch; do not use any phone in your building.
 - Immediately call your gas supplier from a neighbor's phone. Follow the gas supplier's instructions.
 - If you cannot reach your gas supplier, call the fire department.
- Installation and service must be performed by a qualified installer, service agency or the gas supplier.

AVERTISSEMENT : Assurez-vous de bien suivre les instructions données dans cette notice pour réduire au minimum le risque d'incendie ou d'explosion ou pour éviter tout dommage matériel, toute blessure ou la mort.

- Ne pas entreposer ni utiliser d'essence ni d'autres vapeurs ou liquides inflammables dans le voisinage de cet appareil ou de tout autre appareil.
- **QUE FAIRE SI VOUS SENTEZ UNE ODEUR DE GAZ :**
 - Ne pas tenter d'allumer d'appareil.
 - Ne touchez à aucun interrupteur. Ne pas vous servir des téléphones se trouvant dans le bâtiment où vous trouvez.
 - Appelez immédiatement votre fournisseur de gaz depuis un voisin. Suivez les instructions du fournisseur.
 - Si vous ne pouvez rejoindre le fournisseur de gaz, appelez le service des incendies.
- L'installation et l'entretien doivent être assurés par un installateur ou un service d'entretien qualifié ou par le fournisseur de gaz.

TABLE OF CONTENTS

Packaging	Page 2
Introduction	Page 2
General Information	Page 2
Requirements for the	
Commonwealth of Massachusetts	Page 4
New York City Approval.....	Page 4
Cold Climate Insulation	Page 5
Manufactured Home Requirements	Page 5
Location	Page 5
Vent Termination Clearances	Page 6
Appliance and Vent Clearances	Page 8
Detailed Installation Steps.....	Page 10
Typical Installation Sequence	Page 10
Step 1. Framing.....	Page 10
Fireplace and Framing Specifications	Page 11
Step 2. Routing Gas Line	Page 12
Step 3. Appliance Vent Collar.....	Page 13
Step 4. Install The Venting System	Page 13
Vertical Termination Systems.....	Page 14
Vent Section Length Chart	Page 14
Vertical Vent Tables and Figures.....	Page 17
Horizontal Termination System	Page 19
Horizontal Vent Tables and Figures	Page 21
Venting Using Flexible Vent Pipe.....	Page 24
Step 5. Field Wiring.....	Page 25
Step 6. Optional Blower Kit Wiring	Page 26
Step 7. Connecting Gas Line	Page 26
Step 8. Verifying Appliance Operation	Page 27
Step 9. Installing Logs	Page 28
Step 10. Remove/Install Glass Door	Page 32
Step 11. Burner Adjustments	Page 32
Step 12. Hood Installation.....	Page 34
Finishing Requirements	Page 34
Step 13. Attaching Safety-in-Operation Warnings.....	Page 35
Installation Accessories	Page 36
Gas Conversion Kits	Page 38

Please read and understand these instructions before beginning your installation.



We recommend that our gas hearth products be installed and serviced by professionals who are certified in the U.S. by the National Fireplace Institute® (NFI) as NFI Gas Specialists.

PACKAGING

The assembled vented gas fireplace heater is packaged with:

- 1 - the logs are packaged in a carton located within the firebox.
- 2 - one plastic bag of glowing embers is located in the bottom compartment.
- 3 - one envelope containing the literature package which consists of the care and operations manual, installation instructions, warning labels and warranty; envelope is located in the bottom compartment.
- 4 - one vent restrictor to be applied as shown on **page 13**; restrictor is taped to the envelope.
- 5 - one hood taped to the front of the standoff bracket at the top of the unit.
- 6 - three-piece ceramic ember panel.

INTRODUCTION

The **Millivolt** appliances have a millivolt gas control valve with piezo ignition system. If any optional accessories that will require electrical power are to be installed, the electrical power must be provided at the time of appliance installation.

The **Electronic** appliances are designed to operate on natural or propane gas. An electronic intermittent pilot ignition system provides safe, efficient operation. External electrical power is required to operate these units.

These vented gas fireplace heaters are sealed combustion, air-circulating gas fireplaces designed for residential applications.

Approved Vent Components - These fireplaces are designed, tested and listed for operation and installation with the following vent components only:

- **Secure Vent™** Direct-Vent System Components manufactured by Security Chimneys International,
- **Secure Flex™** Flexible Vent Components manufactured by Security Chimneys International and
- **Z-FLEX™** Model GA Venting Systems listed to UL1777 and ULCS635 manufactured by Flexmaster Canada Limited.

Use only the correct size venting (4-1/2" inner and 7-1/2" outer).

These approved vent system components are labeled for identification. DO NOT use any other manufacturer's vent components with these appliances.

GENERAL INFORMATION

WARNING

Young children should be carefully supervised when they are in the same room as the appliance. Toddlers, young children and others may be susceptible to accidental contact burns. A physical barrier is recommended if there are at risk individuals in the house. To restrict access to a fireplace or stove, install an adjustable safety gate to keep toddlers, young children and other at risk individuals out of the room and away from hot surfaces.

AVERTISSEMENT

Les jeunes enfants devraient être surveillés étroitement lorsqu'ils se trouvent dans la même pièce que l'appareil. Les tout petits, les jeunes enfants ou les adultes peuvent subir des brûlures s'ils viennent en contact avec la surface chaude. Il est recommandé d'installer une barrière physique si des personnes à risques habitent la maison. Pour empêcher l'accès à un foyer ou à un poêle, installez une barrière de sécurité; cette mesure empêchera les tout petits, les jeunes enfants et toute autre personne à risque d'avoir accès à la pièce et aux surfaces chaudes.

Children and adults should be alerted to the hazards of high surface temperature and should stay away to avoid burns or clothing ignition.

Les enfants et les adultes devraient être informés des dangers que posent les températures de surface élevées et se tenir à distance afin d'éviter des brûlures ou que leurs vêtements ne s'enflamment.

DO NOT ATTEMPT TO ALTER OR MODIFY THE CONSTRUCTION OF THE APPLIANCE OR ITS COMPONENTS. ANY MODIFICATION OR ALTERATION MAY VOID THE WARRANTY, CERTIFICATION AND LISTINGS OF THIS UNIT.

⚠ WARNING

Improper installation, adjustment, alteration, service or maintenance can cause injury or property damage. Refer to this manual. For assistance or additional information consult a qualified installer, service agency or the gas supplier.

⚠ WARNING

Failure to comply with these installation instructions will result in an improperly installed and operating appliance, voiding its warranty. Any change to this appliance and/or its operating controls is dangerous.

⚠ WARNING

Clothing or other flammable material should not be placed on or near the appliance.

⚠ AVERTISSEMENT

On ne devrait pas placer de vêtements ni d'autres matières inflammables sur l'appareil ni à proximité.

⚠ WARNING

Any safety screen or guard removed for servicing the appliance must be replaced prior to operating the appliance.

⚠ AVERTISSEMENT

Tout écran ou protecteur retiré pour permettre l'entretien de l'appareil doit être remis en place avant de mettre l'appareil en marche.

Note: Installation and repair should be done by a qualified service person. The appliance should be inspected before use and at least annually by a professional service person. More frequent cleaning may be required due to excessive lint from carpeting, bedding material, etcetera. It is imperative that control compartments, burners and circulating air passageways of the appliance be kept clean.

Remarque: L'installation et la réparation devrait être confiées à un technicien qualifié. L'appareil devrait faire l'objet d'une inspection par un technicien professionnel avant d'être utilisé et au moins une fois l'an par la suite. Des nettoyages plus fréquents peuvent être nécessaires si les tapis, la literie, et cetera produisent une quantité importante de poussière. Il est essentiel que les compartiments abritant les commandes, les brûleurs et les conduits de circulation d'air de l'appareil soient tenus propres.

Do not use these appliances if any part has been under water. Immediately call a qualified, professional service technician to inspect the appliance and to replace any parts of the control system and any gas control which have been under water.

Ne pas utiliser cet appareil s'il a été plongé, même partiellement, dans l'eau. Appeler un technicien qualifié pour inspecter l'appareil et remplacer toute partie du système de commande et toute commande qui a été plongée dans l'eau.

IMPROPER INSTALLATION OR USE OF THIS APPLIANCE CAN CAUSE SERIOUS INJURY OR DEATH FROM FIRE, BURNS, EXPLOSION OR CARBON MONOXIDE POISONING.

Only trim kit(s) supplied by the manufacturer shall be used in the installation of this appliance.

Seules les trousse de garniture fournies par le fabricant doivent être utilisées pour l'installation de cet appareil.

These appliances comply with National Safety Standards and are tested and listed by OMNI-Test Laboratories, Inc. (Report No. 116-F-13-4) to ANSI Z21.88 (in Canada, CSA-2.33), and CAN/CGA-2.17-M91 in both USA and Canada, as vented gas fireplace heaters.

Both millivolt and electronic versions of these appliances are listed by OMNI-Test Laboratories for installation in bedrooms and Manufactured Homes.

Misc. Codes / Standards -

The Installation must conform to local codes or, in the absence of local codes, with the *National Fuel Gas Code, ANSI Z223.1/NFPA 54 - latest edition* (In Canada, the current CAN/CSA-B149.1 installation code).

The appliance, when installed, must be electrically grounded and wired in accordance with local codes or, in the absence of local codes, with the *National Electrical Code, ANSI/NFPA 70 - latest edition*, or the *Canadian Electrical Code, CSA C22.1 - latest edition*.

Provide adequate clearances around air openings and adequate accessibility clearance for service and proper operation. Never obstruct the front or back openings of the appliance.

These appliances are designed to operate on natural or propane gas only. The use of other fuels or combination of fuels will degrade the performance of this system and may be dangerous.

These fireplaces are designed as supplemental heaters. Therefore, it is advisable to have an alternate primary heat source when installed in a dwelling.

Millivolt Models - The millivolt appliances are manually controlled and feature a spark igniter (piezo) that allows the appliance's pilot gas to be lit without the use of matches or batteries. This system provides continued service in the event of a power outage.

Millivolt models come standard with a manually-modulated gas valve; flame appearance and heat output can be controlled at the gas valve. The BTU Input for these appliances is shown in **Table 1**.

Electronic Models - Electronic models have a fixed rate gas valve. Input of electronic models is shown in **Table 1**.

Input (BTU/HR) Gas Valves (all models)		
Models	Input Rate (BTU / HR)	
	Nat. Gas	Prop. Gas
MPDT/R-3328 (Millivolt)	17,500 high 11,700 low	17,500 high 14,000 low
MPD-3530 (Millivolt)	20,000 high 12,800 low	20,000 high 15,200 low
MPD-4035 (Millivolt)	27,000 high 18,500 low	27,000 high 21,500 low
MPD-4540 (Millivolt)	29,000 high 20,500 low	29,000 high 22,500 low
MPDT/R-3328 (Electronic)	17,500	17,500
MPD3530 (Electronic)	20,000	20,000
MPD4035 (Electronic)	27,000	27,000
MPD4540 (Electronic)	29,000	29,000

Table 1

Gas Pressure - All Models

Tables 2 and 3 show the appliances' inlet and manifold gas pressure requirements:

Inlet Gas Supply Pressure (all models)		
Fuel #	Minimum	Maximum
Natural Gas	4.5" WC (1.12 kPa)	10.5" WC (2.61 kPa)
Propane	11.0" WC (2.74 kPa)	13.0" WC (3.23 kPa)

Table 2

Manifold Gas Supply Pressure (all models)		
Fuel #	Low	High
Natural Gas	(Lo) 2.2" WC (0.55 kPa)	(Hi) 3.5" WC (0.87 kPa)
Propane	(Lo) 6.3" WC (1.57 kPa)	(Hi) 10.0" WC (2.49 kPa)

Table 3

Test gauge connections are provided on the front of the millivolt and electronic gas control valve (identified IN for the inlet and OUT for the manifold side). The control valves have a 3/8" (10mm) NPT thread inlet and outlet side of the valve (refer to Figures 1 and 2).

Propane tanks are at pressures that will cause damage to valve components. Verify that the tanks have step down regulators to reduce the pressure to safe levels.

These appliances must be isolated from the gas supply piping system (by closing their individual manual shut-off valve) during any pressure testing of the gas supply piping system at test pressures equal to or **less than** 1/2 psig (3.5 kPa).

These appliances and their individual shut-off valves must be disconnected from the gas supply piping system during any pressure testing of that system at pressures **greater than** 1/2 psig (3.5 kPa).

These appliances must not be connected to a chimney or flue serving a separate solid fuel burning appliance.

Orifice Sizes - Sea Level to High Altitude (All Models)

These appliances are tested and approved for installation at elevations of 0-4500 feet (0-1372 meters) above sea level using the standard burner orifice sizes (marked with an "*" in Table 4).

For elevations above 4500 feet, contact your gas supplier or qualified service technician.

Deration - At higher elevations, the amount of BTU fuel value delivered must be reduced by either using gas that has been derated by the gas company or by changing the burner orifice to a smaller size as regulated by the local authorities having jurisdiction and by the (USA) National Fuel Gas Code NFPA 54/ANSI Z223.1 - latest edition or, in Canada, the CAN/CSA-B149.1 codes - latest edition.

Install the appliance according to the regulations of the local authorities having jurisdiction and, in the USA, the National Fuel Gas Code NFPA 54 / ANSI Z223.1 - latest edition or, in Canada, the CAN/CSA-B149.1 - latest edition.

Flame breadth, height and width will diminish 4% for every 1,000 feet of altitude.

Burner Orifice Sizes Elevation 0-4500 feet (0-1372 meters)		
Model Series	Nat. Gas drill size (inches)	Propane drill size (inches)
MPDT-3328 MPDR-3328	#45 (0.0820")* 39L66•	0.048 inch 99K78•
MPD-3530	#44 (0.0860")* 60J80•	#55 (0.0520")* 19L52•
MPD-4035	#37 (0.1040")* 24M10•	0.063 inch 21L01•
MPD-4540	#36 (0.1065")* 18L40•	#52 (0.0635")* 37G00•

Table 4 * Standard size installed at factory
• Part /Cat. Number

Gas Valve Diagrams

See Figure 1 for Millivolt models and Figure 2 For Electronic Models.

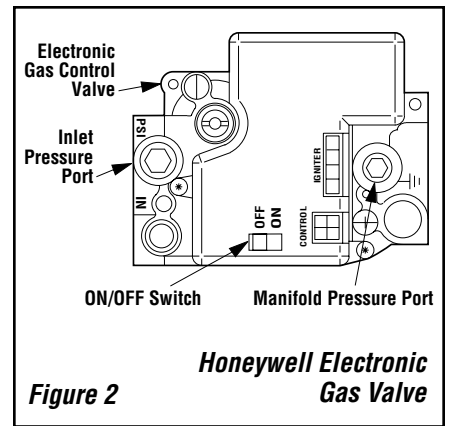
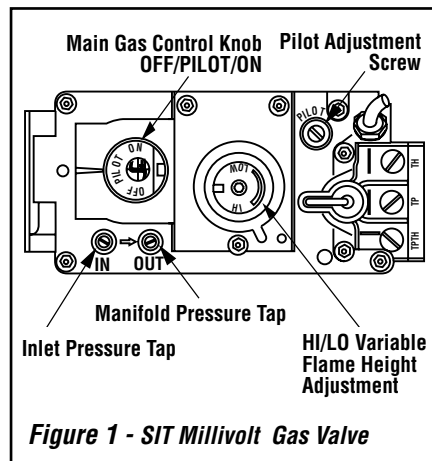

REQUIREMENTS FOR THE COMMONWEALTH OF MASSACHUSETTS

These fireplaces are approved for installation in the US state of Massachusetts if the following additional requirements are met:

- Install this appliance in accordance with Massachusetts Rules and Regulations 248 C.M.R.
- Installation and repair must be done by a plumber or gas fitter licensed in the Commonwealth of Massachusetts.
- The flexible gas line connector used shall not exceed 36 inches (92 centimeters) in length.
- The individual manual shut-off must be a T-handle type valve.

Massachusetts Horizontal Vent Requirements

In the Commonwealth of Massachusetts, horizontal terminations installed less than seven (7) feet above the finished grade must comply with the following additional requirements:

- A hard wired carbon monoxide detector with an alarm and battery back-up must be installed on the floor level where the gas fireplace is installed. The carbon monoxide detector must comply with NFPA 720, be ANSI/UL 2034 listed and be ISA certified.
- A metal or plastic identification plate must be permanently mounted to the exterior of the building at a minimum height of eight (8) feet above grade and be directly in line with the horizontal termination. The sign must read, in print size no less than one-half (1/2) inch in size, GAS VENT DIRECTLY BELOW. KEEP CLEAR OF ALL OBSTRUCTIONS.

NEW YORK CITY, NEW YORK (MEA)

Installation of these fireplaces are approved for installation in New York City in the US state of New York.

NOTE: DIAGRAMS & ILLUSTRATIONS ARE NOT TO SCALE.

COLD CLIMATE INSULATION

For cold climate installations, seal all cracks around your appliance with noncombustible material and wherever cold air could enter the room. It is especially important to insulate outside chase cavity between studs and under floor on which appliance rests, if floor is above ground level. Gas line holes and other openings should be caulked or stuffed with unfaced fiberglass insulation.

If the fireplace is being installed on a cement slab in cold climates, a sheet of plywood or other raised platform can be placed underneath to prevent conduction of cold transferring to the fireplace and into the room. It also helps to sheetrock inside surfaces and tape for maximum air tightness and caulk firestops.

MANUFACTURED HOME REQUIREMENTS

This appliance may be installed in an aftermarket permanently located, manufactured home and must be installed in accordance with the manufacturer's instructions and the Manufactured Home Construction and Safety Standard, Title 24 CFR, Part 3280, in the United States, or the Standard for Installation in Mobile Homes, CAN/CSA Z240 MH Series, in Canada.

Cet appareil peut être installé comme du matériel d'origine dans une maison préfabriquée (É.U. seulement) ou mobile et doit être installé selon les instructions du fabricant et conformément à la norme Manufactured Home Construction and Safety, Title 24 CFR, Part 3200 aux Unis ou à la norme Can/CSA-Z240 Série MM, Maisons mobiles au Canada.

This appliance is only for use with the type of gas indicated on the rating plate. This appliance is not convertible for use with other gases, unless a certified kit is used.

Cet appareil doit être utilisé uniquement avec le type de gaz indiqué sur la plaque signalétique. Cet appareil ne peut être converti à d'autres gaz, sauf si une trousse de conversion est utilisée.

CAUTION: Ensure that the cross members are not cut or weakened during installation. The structural integrity of the manufactured home floor, wall, and ceiling / roof must be maintained.

CAUTION: This appliance must be grounded to the chassis of the manufactured home in accordance with local codes or in the absence of local codes, with the National Electrical Code ANSI / NFPA 70 - latest edition or the Canadian Electrical Code CSA C22.1 - latest edition.

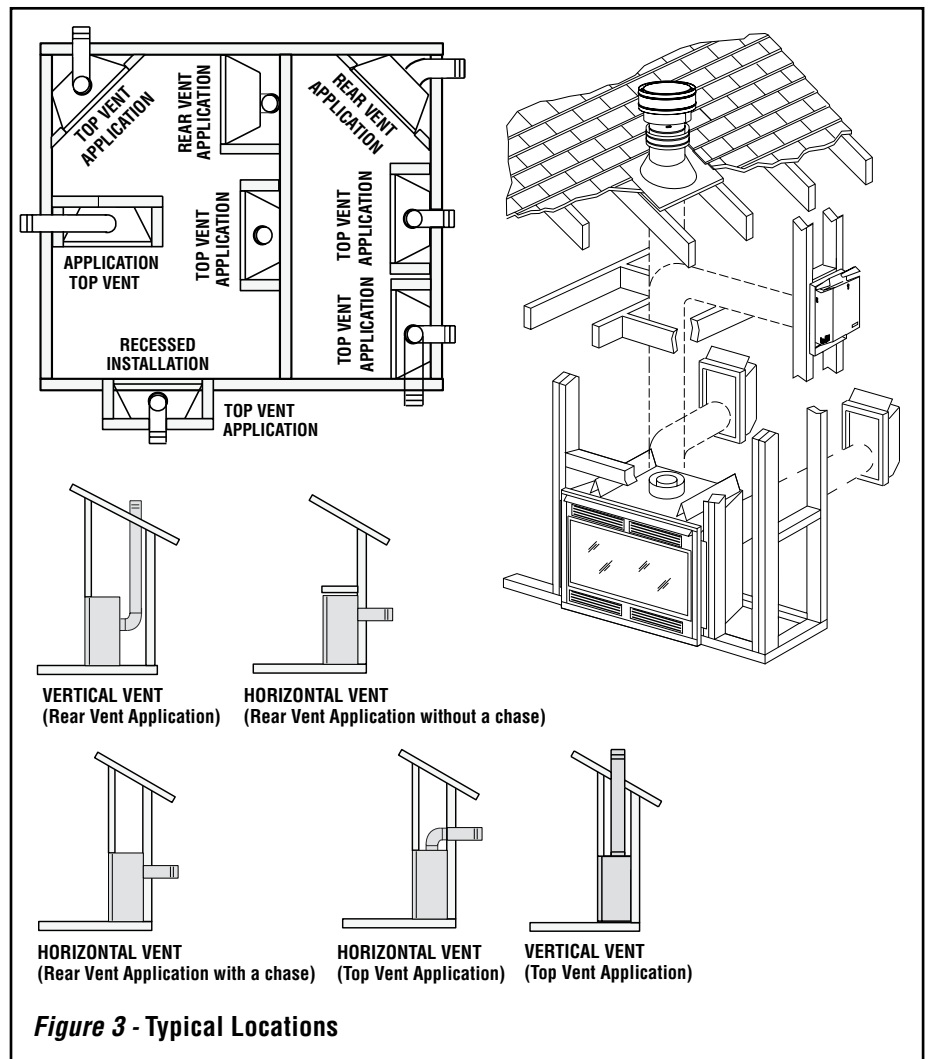

LOCATION

In selecting the location, the aesthetic and functional use of the appliance are primary concerns. However, vent system routing to the exterior and access to the fuel supply are also important.

Due to high temperatures, the appliance should be located out of traffic and away from furniture and draperies (Figure 3).

En raison des températures élevées, l'appareil devrait être installé dans un endroit où il y a peu de circulation et loin du mobilier et des tentures (Figure 3).

The location should also be free of electrical, plumbing or other heating/air conditioning ducting.

These direct-vent appliances are uniquely suited for installations requiring a utility shelf positioned directly above the fireplace. Utility shelves like these are commonly used for locating television sets and decorative plants.

Be aware that this is a heat producing appliance. Objects placed above the unit are exposed to elevated temperatures.

Do not insulate the space between the appliance and the area above it (see Figure 8).

The minimum height from the base of the appliance to the underside of combustible materials used to construct a utility shelf in this fashion is shown in **Figure 8**.

The appliance should be mounted on a fully supported base extending the full width and depth of the unit. The appliance may be located on or near conventional construction materials. However, if installed on combustible materials, such as carpeting, vinyl tile, etc., a metal or wood barrier covering the entire bottom surface must be used.

VENT TERMINATION CLEARANCES

These instructions should be used as a guideline and do not supersede local codes in any way. Install venting according to local codes, these instructions, the current National Fuel Gas Code (ANSI-Z223.1) in the USA or the current standards of CAN/CSA-B149.1 in Canada.

Vertical Vent Termination Clearances

Terminate multiple vent terminations according to the installation codes listed above and **Figures 4 and 5**.

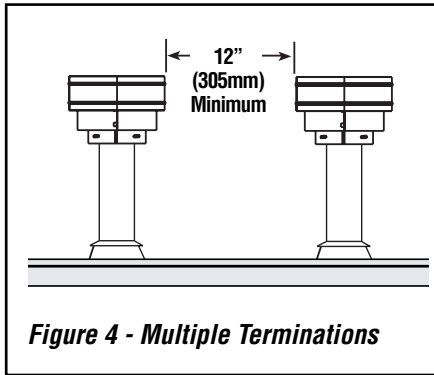
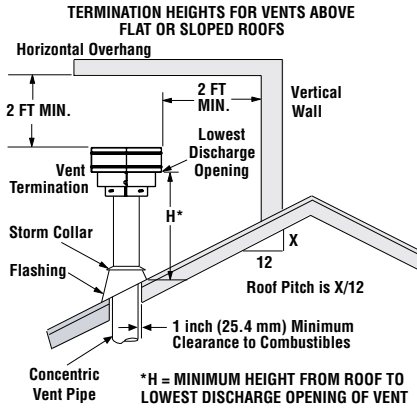

Figure 4 - Multiple Terminations

Vertical Vent Termination Clearances



The vent / air intake termination clearances above the high side of an angled roof is as shown in the following chart:

Termination Heights For Vents Above Flat Or Sloped Roofs Ref. NFPA 54 / ANSI Z223.1		
Roof Pitch	* Feet	* Meters
Flat to 6/12	1.0	0.3
6/12 to 7/12	1.25	0.38
7/12 to 8/12	1.5	0.46
8/12 to 9/12	2.0	0.61
9/12 to 10/12	2.5	0.76
10/12 to 11/12	3.25	0.99
11/12 to 12/12	4.0	1.22
12/12 to 14/12	5.0	1.52
14/12 to 16/12	6.0	1.83
16/12 to 18/12	7.0	2.13
18/12 to 20/12	7.5	2.29
20/12 to 21/12	8.0	2.44

Figure 5

Horizontal Vent Termination Clearances

The horizontal vent termination must have a minimum of 6" (152 mm) clearance to any overhead combustible projection of 2-1/2" (64 mm) or less (see **Figure 6**). For projections exceeding 2-1/2" (64 mm), see **Figure 6**. For additional vent location restrictions refer to **Figure 7** on **Page 7**.

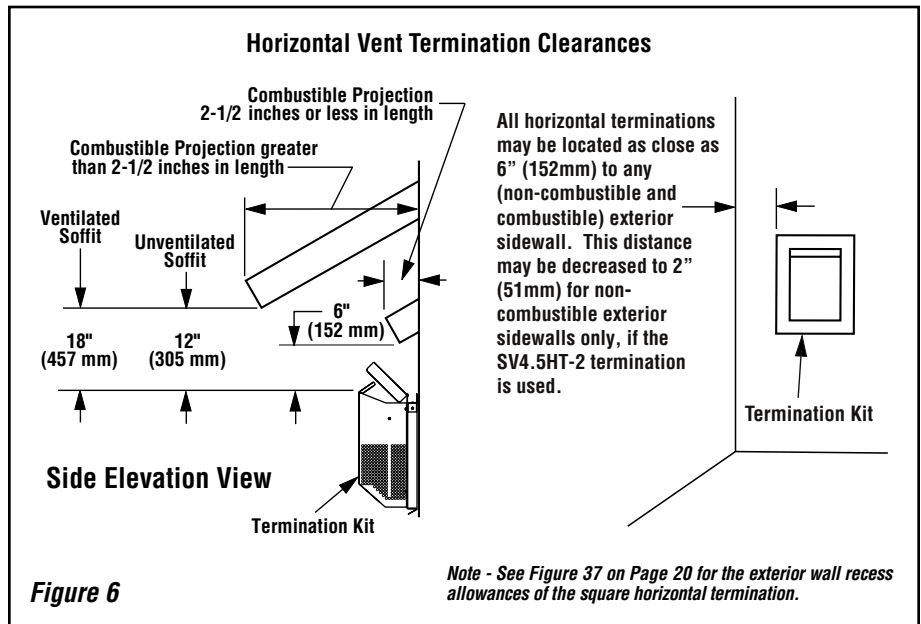
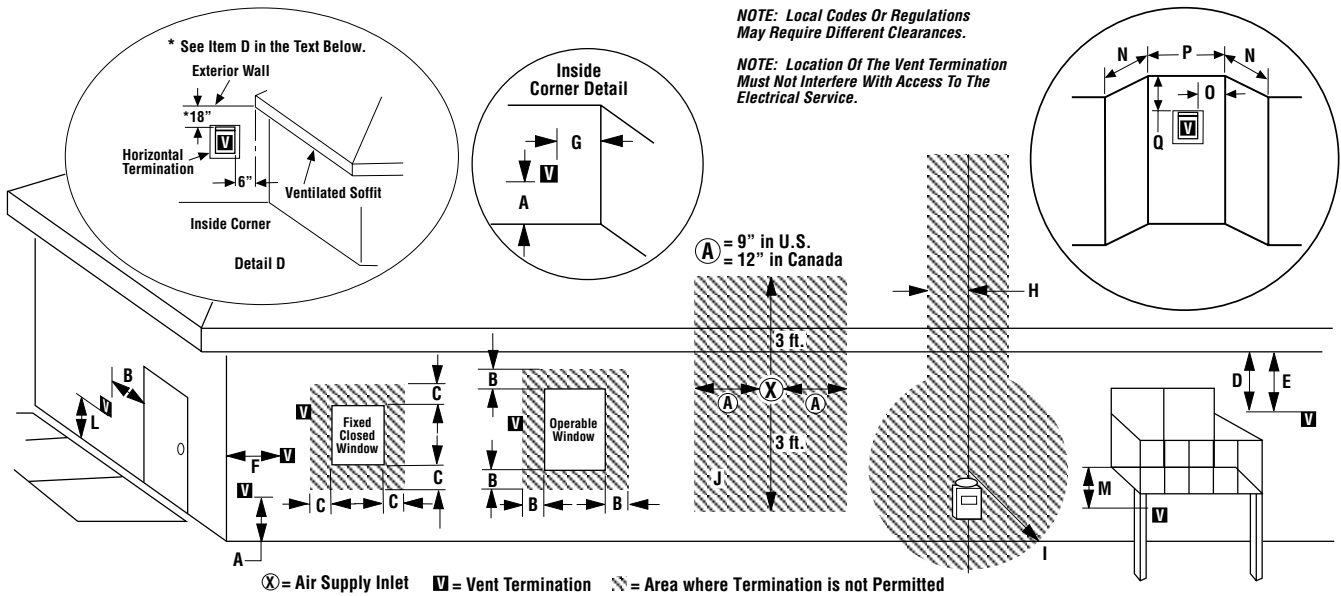

Figure 6

Note - See Figure 37 on Page 20 for the exterior wall recess allowances of the square horizontal termination.

EXTERIOR HORIZONTAL VENT TERMINATION CLEARANCE REQUIREMENTS



	Canadian Installation*	US Installation**
A = Clearance above grade, veranda, porch, deck, or balcony.	12 inches (30cm)*	12 inches (30cm)**
B = Clearance to window or door that may be opened.	6 inches (15cm) for appliances < 10,000 Btuh (3kW), 12 inches (30cm) for appliances > 10,000 Btuh (3kW)	6 inches (15cm) for appliances < 10,000 Btuh (3kW), 9 inches (23cm) for appliances > 10,000 Btuh (3kW) and < 50,000 Btuh (15kW), 12 inches (30cm) for appliances > 50,000 Btuh (15kW)**
C = Clearance to permanently closed window	12 inches (305mm) recommended to prevent window condensation	9 inches (229mm) recommended to prevent window condensation
D = Vertical clearance to ventilated soffit located above the termination within a horizontal distance of 18 inches (458mm)	18 inches (458mm)	18 inches (458mm)
E = Clearance to unventilated soffit	12 inches (305mm)	12 inches (305mm)
F = Clearance to outside corner	5 inches (12.7cm) minimum	5 inches (12.7cm) minimum
G = Clearance to inside corner	2 inches (5.08cm) minimum - SV4.5HT-2• 6 inches (15.2cm) minimum - SV4.5HTSS	2 inches (5.08cm) minimum - SV4.5HT-2• 6 inches (15.2cm) minimum - SV4.5HTSS
H = Clearance to each inside of center line extended above meter/regulator assembly	3 feet (91cm) within a height of 15 feet above the meter/regulator assembly*	3 feet (91cm) within a height of 15 feet above the meter/regulator assembly**
I = Clearance to service regulator vent outlet	3 feet (91cm)*	3 feet (91cm)**
J = Clearance to nonmechanical air supply inlet to building or the combustion air inlet to any other appliance	6 inches (15cm) for appliances < 10,000 Btuh (3kW), 12 inches (30cm) for appliances > 10,000 Btuh (3kW)	6 inches (15cm) for appliances < 10,000 Btuh (3kW), 9 inches (23cm) for appliances > 10,000 Btuh (3kW) and < 50,000 Btuh (15kW), 12 inches (30cm) for appliances > 50,000 Btuh (15kW)**
K = Clearance to a mechanical air supply inlet	6 feet (1.83m)*	3 feet (91cm) above if within 10 feet (3m) horizontally**
L = Clearance above paved sidewalk or paved driveway located on public property	7 feet (2.13m)‡	7 feet (2.13m)‡
M = Clearance under veranda, porch, deck or balcony	12 inches (30cm)*‡	12 inches (30cm)‡
N = Depth of Alcove (Maximum)	6 feet (1.83m)*	6 feet (1.83m)**
O = Clearance to Termination (Alcove)	6 inches (15.2mm)*	6 inches (15.2mm)**
P = Width of Alcove (Minimum)	3 feet (91cm)*	3 feet (91cm)*
Q = Clearance to Combustible Above (Alcove)	18 inches (457mm)*	18 inches (457mm)**

* In accordance with the current CSA-B149.1 National Gas And Propane Installation Code.

** In accordance with the current ANSI S223.1/NFPA 54 National Fuel Gas Codes.

‡ A vent shall not terminate directly above a sidewalk or paved driveway which is located between two single family dwellings and serves both dwellings.

*‡ Only permitted if veranda, porch, deck or balcony is fully open on a minimum 2 sides beneath the floor.

•2 inch Clearance to Non-Combustibles for SV4.5HT-2 Only.

Figure 7

NOTE: DIAGRAMS & ILLUSTRATIONS ARE NOT TO SCALE.

MINIMUM CLEARANCES TO COMBUSTIBLES

Appliance And Vent Clearances

The appliance is approved with zero clearance to combustible materials on all sides (as detailed in **Table 5**), with the following exception: **When the unit is installed with one side flush with a wall, the wall on the other side of the unit must not extend beyond the front edge of the unit.** In addition, when the unit is recessed, the side walls surrounding the unit must not extend beyond the front edge of the unit (see **Figure 3**).

Hearth Extension - A hearth extension is not required with this appliance. If a hearth extension is used, do not block the lower control compartment door. Any hearth extension used is for appearance only and does not have to conform to standard hearth extension installation requirements.

Shelf Height - To provide for the lowest possible shelf surface, use the alternate rear vent outlet, the venting attached to the top vent should be routed in a way to minimize obstructions to the space above the appliance. **Do not insulate the space between the appliance and the area above it (see Figure 8).** The minimum height from the base of the appliance to the underside of combustible materials used to construct a utility shelf in this fashion is shown in **Figure 8**.

The appliance should be mounted on a fully supported base extending the full width and depth of the unit. The appliance may be located on or near conventional construction materials. However, if installed on combustible materials, such as carpeting, vinyl tile, etc., a metal or wood barrier covering the entire bottom surface must be used.

MINIMUM CLEARANCES* Inches (millimeters)	
Back	1/2 in. (13) 0 (0) from Spacers Or Dimples
Sides	1/2 in. (13) 0 (0) from Spacers Or Dimples **
Top Spacers	0 (0)
Floor	0 (0)
From Bottom of Unit To Ceiling	64 (1626)
Vent	3 (76) Top* / 1 (25.4) Sides & Bottom
SERVICE CLEARANCES Feet (meters)	
Front	3 feet (0.9 meters)

Table 5

*Note: 3 in. (75 mm) above any horizontal/inclined vent component.

**Note: See Page 10, Step 1 for clearance requirements to the nailing flange located at each side of the unit and any screw heads adjacent to it.

Models	Combustible Shelf Height - Inches (millimeters)			
	Top Vent - With One 90 Degree Elbow		Rear Vent - Straight Out The Back	
	Secure Vent	Secure Flex	Secure Vent	Secure Flex
MPDT-3328 MPDR-3328	44-1/2 (1130)	46-1/4 (1175)	33-1/4 (845)	33-1/4 (845)
MPD-3530	46-1/2 (1181)	48-1/4 (1226)	35-1/4 (895)	35-1/4 (895)
MPD-4035 MPD-4540	51-1/2 (1308)	53-1/4 (1353)	40-1/4 (1022)	40-1/4 (1022)

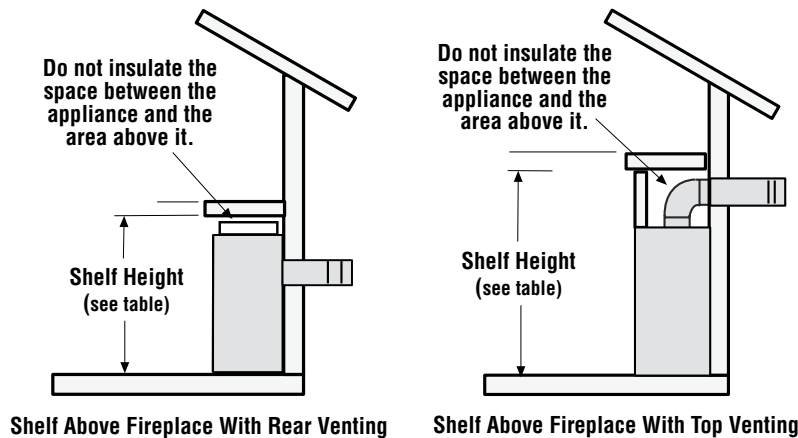

Figure 8 - Shelf Height Minimum Clearances With Top Venting

Wall Finishes / Surrounds / Mantels

Note: Combustible wall finish materials and/or surround materials must not be allowed to encroach the area defined by the appliance front face (black sheet metal). **Never allow combustible materials to be positioned in front of or overlapping the appliance face** (see **Figures 65 and 66** on **Page 34**).

Non-combustible materials, such as surrounds and other appliance trim, may be installed on the appliance face with these exceptions: they must not cover any portion of the removable glass panel or control compartment.

Vertical installation clearances to combustible mantels vary according to the depth of the mantel. See **Figure 9**. Mantels constructed of non-combustible materials may be installed at any height above the appliance opening; however, do not allow anything to hang below the fireplace hood.

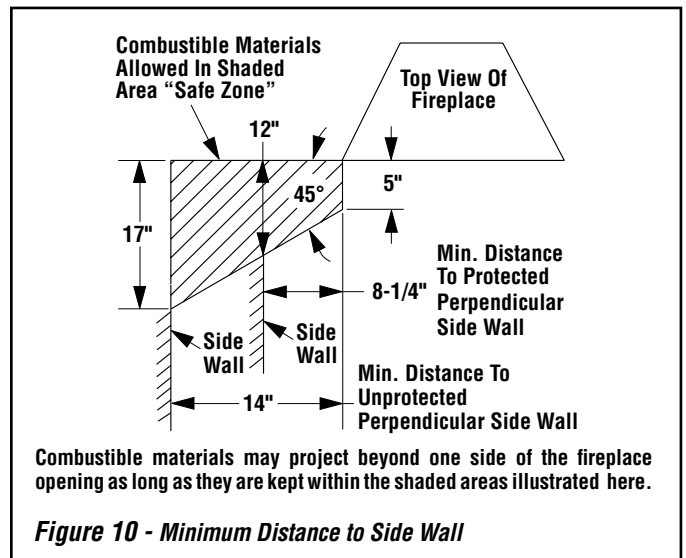
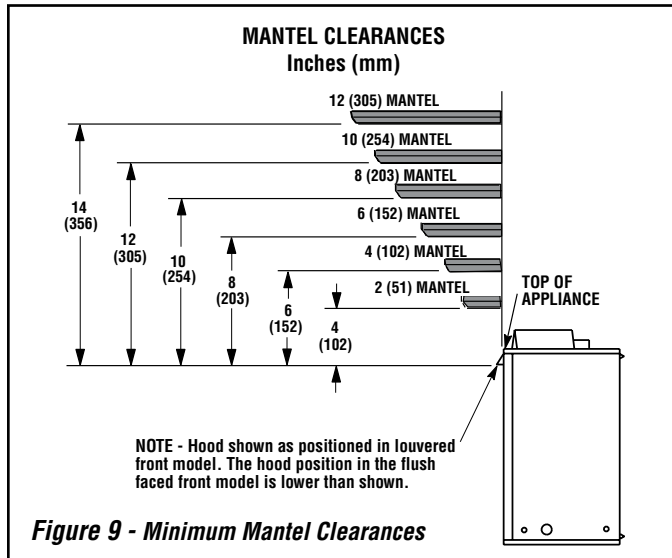

⚠️ WARNING

Failure to position the parts in accordance with these diagrams or failure to use only parts specifically approved with this appliance may result in property damage or personal injury.

⚠️ AVERTISSEMENT

Risque de dommages ou de blessures si les pièces ne sont pas installées conformément à ces schémas et ou si des pièces autres que celles spécifiquement approuvées avec cet appareil sont utilisées.

DETAILED INSTALLATION STEPS

The appliance is shipped with all gas controls and components installed and pre-wired.

1. Remove the shipping carton. Remove the shipping pad, exposing the front glass door.
2. Open the two latches (located under the firebox floor) securing the glass door. Remove the door by tilting it outward at the bottom and lifting it up. Set the door aside protecting it from inadvertent damage. See *Removing Glass Panels* on **Page 32**.
3. Remove the top louvered panel and locate the pressure relief plates (see **Figure 11**).
4. Lift the pressure relief plates and remove the cardboard from beneath each plate (be careful not to damage the white gasket).

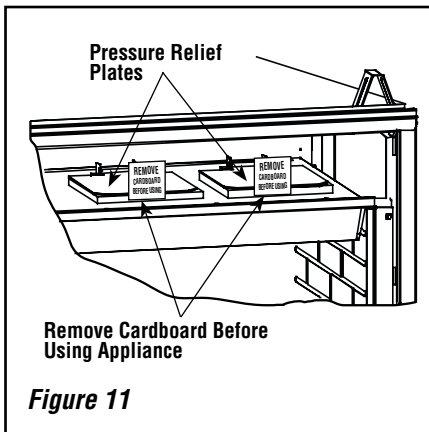

TYPICAL INSTALLATION SEQUENCE

The typical sequence of installation is outlined below. However, each installation is unique and may result in variations to the steps described.

See the page numbers references in the following steps for detailed procedures.

Step 1. (Page 10) Construct the appliance framing. Position the appliance within the framing and secure with nailing brackets. Bend up the appropriate header spacing guides for the drywall/finish material thickness to be used (refer to **Figure 60, page 32**). Bend up the outer pair for 1/2" materials and the inner pair for 5/8" materials. Bend out the appropriate nailing flanges for the drywall/finish material to be used. Nailing flanges are provided for flush framing, 1/2 inch and 5/8 inch framing depths (see **Figure 12**).

Step 2. (Page 12) Route gas supply line to appliance location.

Step 3. Preparing the appliance vent collar.

Step 4. (Page 13) Install the vent system and exterior termination.

Step 5. (Page 25) Field Wiring

a. Millivolt Appliances – Install the operating control switch (not factory provided) and bring in electrical service line for forced air-circulating blower (optional equipment).

b. Electronic Appliances – Field wire and install operating control switch.

Step 6. (Page 26) Install blower kit (optional equipment).

Step 7. (Page 26) Make connection to gas supply.

Step 8. (Page 27) Verifying appliance operation.

Step 9. (Page 28) Install the logs, decorative volcanic stone and glowing embers.

Step 10. (Page 32) Install glass door assembly.

Step 11. (Page 32) Adjust burner to ensure proper flame appearance.

Step 12. (Page 34) Install the hoods.

Step 13. (Page 35) Attach Safety in Operation Warnings.

Before proceeding it may be helpful to remove the log set from the firebox and remove the embers and volcanic stone from the control compartment. Refer to the following steps:

1. Remove the front glass enclosure panel (see *Removing Glass Enclosure Panels* on **Page 32**).

2. Remove log set box from firebox. Next, remove embers and volcanic stone from control compartment. **Handle logs carefully to prevent breakage.**

Step 1. FRAMING

Frame these appliances as illustrated in **Figures 13 and 14** on **Pages 10 and 11** (**Figure 14** applies to corner framing installations only). All framing details must allow for a minimum clearance to combustible framing members as shown in **Table 5 on Page 8**.

If the appliance is to be elevated above floor level, a solid continuous platform must be constructed below the appliance.

Headers may be in direct contact with the appliance top spacers when they are bent up vertically maintaining the 3" clearance to the fireplace top, but must not be supported by them or notched to fit around them. All construction above the appliance must be self-supporting. **DO NOT** use the appliance for structural support.

The fireplace should be secured to the side framing members using the unit's nailing flanges - one top and bottom on each side of the fireplace front. See **Figure 12**. Use 8d nails or their equivalent.

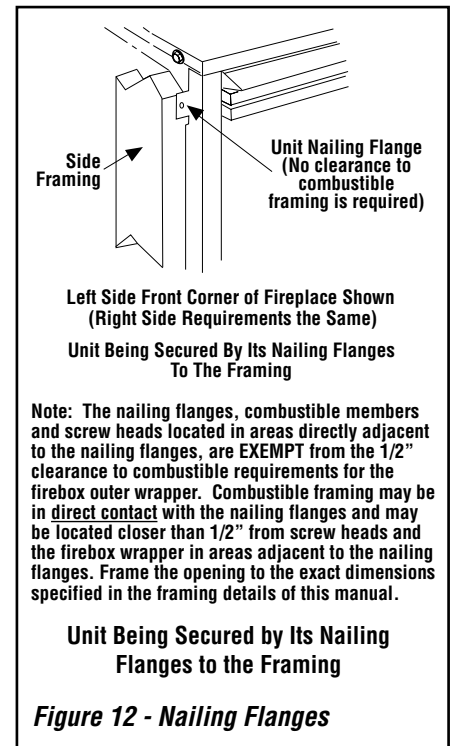

FIREPLACE AND FRAMING SPECIFICATIONS

Framing

Model No.		A	B	C	D	E
MPDT-3328	in.	33 1/4	33 1/4	----	37 3/4	12 7/8
	mm	845	845	----	959	327
MPDR-3328	in.	33 1/4	33 1/4	19 5/8	----	12 7/8
	mm	845	845	498	----	327
MPD-3530	in.	35 1/4	35 1/4	21 11/16	39 3/4	16
	mm	895	895	551	1010	406
MPD-4035	in.	40 1/4	40 1/4	26 11/16	44 3/4	16
	mm	1022	1022	678	1137	406
MPD-4540	in.	45 1/4	40 1/4	26 11/16	44 3/4	16
	mm	1149	1022	678	1137	406

Notes

Diagrams, illustrations and photographs are not to scale – consult installation instructions. Product designs, materials, dimensions, specifications, colors and prices are subject to change or discontinuance without notice.

Canacraft

ENERGUIDE

Look for the **ENERGUIDE** Gas Fireplace Energy Efficiency Rating in this brochure

Based on CSA P.4.1-02

Vent Size

Co-axial DV Vent Size	4-1/2" Inner 7-1/2" Outer
-----------------------	------------------------------

Viewable Glass Size

33" Model	27-1/2" Wide 17" High
35" Model	29-1/2" Wide 18-7/8" High
40" Model	34-1/2" Wide 24" High
45" Model	39-1/2" Wide 24" High

(Louvered Front Model Shown)

FRAMING SPACERS (Top and Sides and Rear)

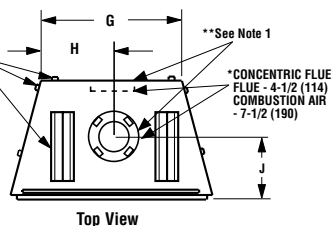

Top View

* MPD models have a top and rear vent
MPDR models have only a rear vent
MPDT models have only a top vent

** Note 1 - Collars protrude one inch on MPDT-3328 and MPDR-3328 models.

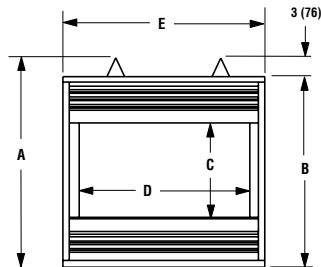

Front View

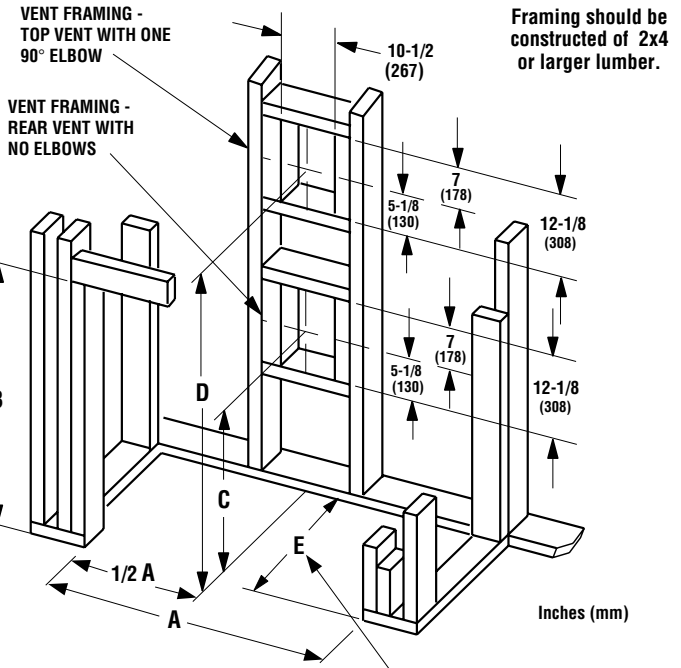

E is the required framing depth dimension when the finish material (drywall) thickness is 1/2 in. (13mm).

Vertical Venting Through the Ceiling:

Frame ceiling opening - Use a plumb line from the ceiling above the appliance to locate center of the vertical run. Cut and/or frame an opening, 10-1/2" x 10-1/2" (267 mm x 267 mm) inside dimensions, about this center mark (see Figure 18).

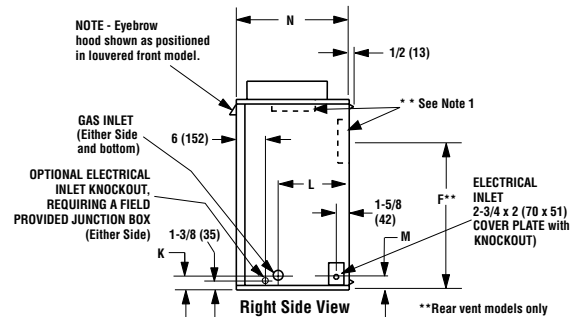

Right Side View

**Rear vent models only

Model No.		A	B	C	D	E	**F	G	H	J	K	L	M	N
MPDT-3328	in.	33 1/8	30 1/8	17	27 1/2	33 1/8	19 5/8	21 1/2	10 3/4	6 13/16	3	8 11/32	2 2/3	13
	mm	841	765	432	699	841	498	546	273	173	76	212	70	330
MPD-3530	in.	35 1/8	32 1/8	19	29 1/2	35 1/8	21 11/16	24 7/8	12 7/16	9	3	9	3	16
	mm	892	816	483	749	892	551	632	316	220	76	220	76	406
MPD-4035	in.	40 1/8	37 1/8	24	34 1/2	40 1/8	26 11/16	29 7/8	14 15/16	9	3	9	3	16
	mm	1019	943	610	876	1019	678	759	379	220	76	220	76	406
MPD-4540	in.	40 1/8	37 1/8	24	39 1/2	45 1/8	26 11/16	34 7/8	17 7/16	9	3	9	3	16
	mm	1146	943	610	1003	1146	678	886	443	220	76	220	76	406

Figure 13

NOTE: DIAGRAMS & ILLUSTRATIONS ARE NOT TO SCALE.

FIREPLACE FRAMING SPECIFICATIONS

Model No.		A	B	C	D	E	F
MPDT-3328	in.	33 1/8	48 1/2	34 5/16	17 3/16	24 1/4	5
MPDR-3328	mm	841	1232	872	437	616	127
MPD-3530	in.	35 1/8	57 1/2	40 5/8	19 3/16	28 3/4	6 1/8
	mm	892	1461	1032	487	730	156
MPD-4035	in.	40 1/8	61 3/16	43 11/32	19 3/16	30 11/16	7 7/8
	mm	1019	1554	1101	487	779	200
MPD-4540	in.	45 1/8	66 3/8	46 15/16	19 3/16	33 3/16	9 3/4
	mm	1146	1686	1192	487	843	248

Note-
Venting requirements for rear vent applications in corner installations -
- the horizontal vent length "a" to "b," must not exceed 28 inches (711 mm)

MPDT-3328 AND MPDR-3328 Models -
Dimensions A to F occur when one 45 degree elbow is connected directly to the appliance collar.

MPD-3530, MPD-4035 and MPD-4540 Models - Dimensions D and F occur when one 45 degree elbow is connected directly to the appliance collar.

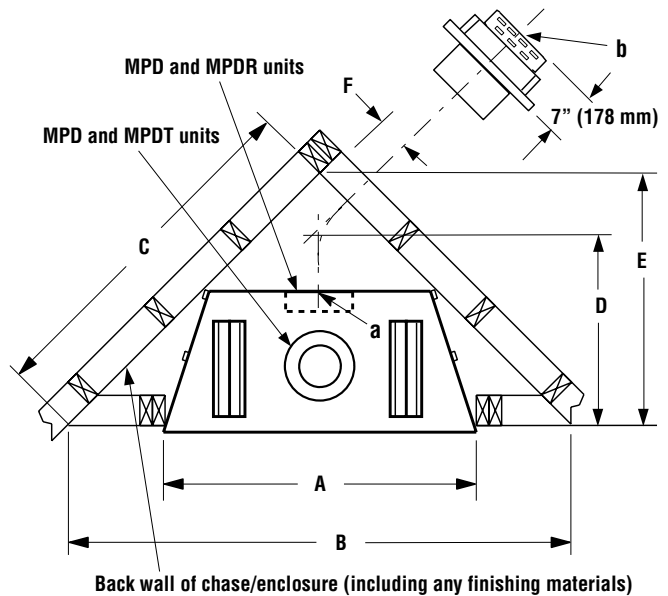

Figure 14 - Corner Framing with Horizontal Termination

Step 2. ROUTING GAS LINE

Route a 1/2" (13 mm) gas line to the left side of the appliance as shown in **Figure 15**. Gas lines must be routed, constructed and made of materials that are in strict accordance with local codes and regulations. All appliances are factory-equipped with a flexible gas line connector and 1/2-inch shutoff valve. (See **Step 6 on Page 25**).

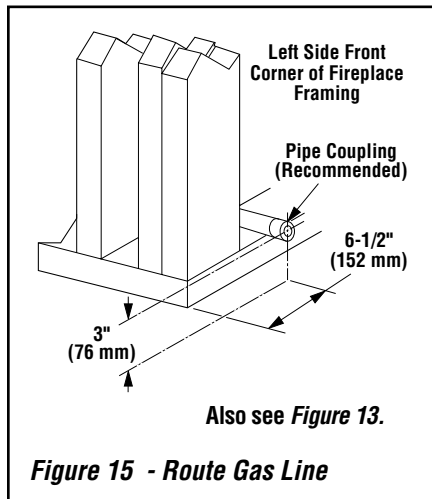

Figure 15 - Route Gas Line

Proper Sizing of Gas Line

Properly size and route the gas supply line from the supply regulator to the area where the appliance is to be installed per requirements outlined in the National Fuel Gas Code, NFPA 54 - latest edition (USA) or CAN/CSA-B149.1 - latest edition (Canada).

Never use galvanized or plastic pipe. Refer to **Table 6** for proper sizing of the gas supply line, if black iron pipe is being used. Gas lines must be routed, constructed and made of materials that are in strict accordance with local codes and regulations. We recommend that a qualified individual such as a plumber or gas fitter be hired to correctly size and route the gas supply line to the appliance. Installing a gas supply line from the fuel supply to the appliance involves numerous considerations of materials, protection, sizing, locations, controls, pressure, sediment, and more. Certainly no one unfamiliar and unqualified should attempt sizing or installing gas piping.

Schedule 40 Black Iron Pipe Inside Diameter (Inches)		
Schedule 40 Pipe Length (feet)	Natural Gas	Propane Gas
0-10	1/2	3/8
10-40	1/2	1/2
40-100	1/2	1/2
100-150	3/4	1/2
150-200	3/4	1/2

Table 6

Notes:

- All appliances are factory-equipped with a flexible gas line connector and 1/2 inch shutoff valve (see **Figure 50 on Page 25**).
- See **Massachusetts Requirements on Page 4** for additional requirements for installations in the state of Massachusetts in the USA.
- The gas supply line should Not be connected to the appliance until **Step 6 (Page 25)**.
- A pipe joint compound rated for gas should be used on the threaded joints. **Ensure propane resistant compounds are used in propane applications.** Be very careful that the pipe compound does not get inside the pipe.
- It is recommended to install a sediment trap in the supply line as close as possible to the appliance. Appliances using Propane should have a sediment trap at the base of the tank.
- Check with local building official for local code requirements (i.e. are below grade penetrations of the gas line allowed?, etc).

IMPORTANT: If propane is used, be aware that if tank size is too small (i.e. under 100-lbs, if this is the only gas appliance in the dwelling. Ref. NPFA 58), there may be loss of pressure, resulting in insufficient fuel delivery (which can result in sooting, severe delayed ignition or other malfunctions). Any damage resulting from an improper installation, such as this, is not covered under the limited warranty.

NOTE: DIAGRAMS & ILLUSTRATIONS ARE NOT TO SCALE.

Step 3. Preparing the Appliance Vent Collar On MPD-3530/4035/4540 Series (Combined Top And Rear Vent) Models

Each of the unit's two vent collars are sealed with a cover plate and a seal plate and gasket. The cover, and seal plate and gasket must be removed from the vent collar being used. Refer to **Figure 16** for top vent usage and **Figure 17** for rear, and the following steps to prepare the appropriate collar for use.

From the vent collar being used, remove the four screws securing the vent seal plate and gasket. Remove and discard the seal plate and gasket.

When the top vent collar is being used, from inside the firebox, loosen the two screws in the keyhole slots of the cover plate and remove the remaining two cover plate securing screws. Remove and discard the cover plate. **Reinstall and securely tighten all four screws.**

When the rear vent collar is being used, from inside the firebox, remove the two screws securing the lintel to the rear wall of the firebox, then remove the lintel. Remove the four cover plate securing screws. Remove and discard the cover plate.

Reinstall and securely tighten all four cover plate screws. Re-secure the lintel to the rear wall of the firebox.

⚠ WARNING

Failure to reinstall and securely tighten cover plate screws could result in leakage of flue products into the living space. Vent cover plate and vent seal cap must remain securely installed on unused vent collar. Failure to do so could result in leakage of flue products into living space.

Step 4. INSTALL THE VENT SYSTEM

These instructions should be used as a guideline and do not supersede local codes in any way. Install venting according to local codes, these instructions, the current National Fuel Gas Code (ANSI-Z223.1) in the USA or the current standards of CAN/CSA-B149.1 in Canada.

Ensure clearances are in accordance with local installation codes and the requirements of the gas supplier.

Dégagement conforme aux codes d'installation locaux et aux exigences du fournisseur de gaz.

Use only approved vent components. See Approved Vent Components on Page 2.

These fireplaces must be vented directly to the outside.

The vent system may not service multiple appliances, and must never be connected to a flue serving a solid fuel burning appliance. The vent pipe is tested to be run inside an enclosed wall (such as a chase). There is no requirement for inspection openings in the enclosing wall at any of the joints in the vent pipe.

Installation of Vent Restrictor

A vent restrictor may be needed with this appliance, install vent restrictor (provided) in the appliance top flue outlet as shown in **Figure 18** (MPDT-3328, MPD-3530, MPD-4035 and MPD-4540) or rear flue outlet as shown in **Figure 19** (MPD-3530, MPD-4035 and MPD-4540). It is held in place by friction, only.

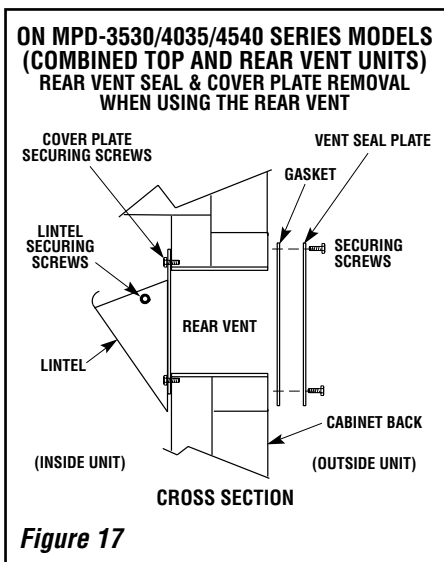
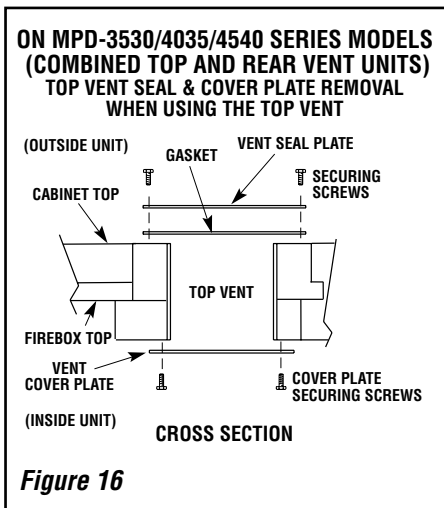

Note: The restrictor is included within the firebox.

Select Venting System - Horizontal or Vertical

With the appliance secured in framing, determine vent routing and identify the exterior termination location. The following sections describe vertical (roof) and horizontal (exterior wall) vent applications. Refer to the section relating to your installation. **A list of approved venting components are shown on Pages 34 and 35.**

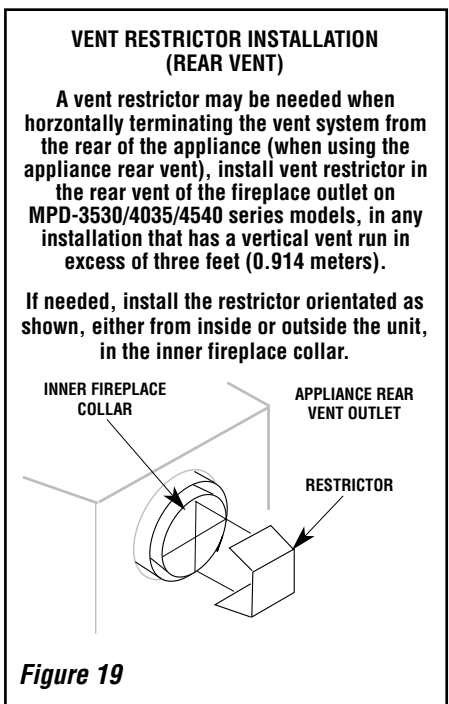
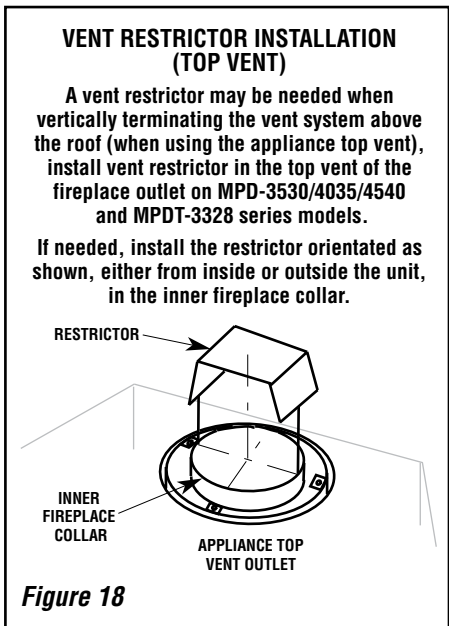

NOTE: DIAGRAMS & ILLUSTRATIONS ARE NOT TO SCALE.

VERTICAL TERMINATION SYSTEMS (ROOF)

See **Figure 20** and **Figures 30 through 32** on **Page 17** and their associated Vertical Vent Tables which illustrate the various vertical venting configurations that are possible for use with these appliances. **Secure Vent™** pipe applications are shown in these Figures; **Secure Flex™** pipe may also be used. A Vertical Vent Table summarizes each system's minimum and maximum vertical and horizontal length values that can be used to design and install the vent components in a variety of applications.

Both these vertical vent systems terminate through the roof. The minimum vent height above the roof and/or adjacent walls is specified in ANSI Z223.1-(latest edition) (In Canada, the current CAN/CSA-B149.1 installation code) by major building codes. Always consult your local codes for specific requirements. A general guide to follow is the Gas Vent Rule (refer to **Figure 5 on Page 6**).

Vertical (Straight) Installation (Figure 20)

Determine the number of straight vent sections required. 4-1/2" (114 mm), 10-1/2" (267 mm), 22-1/2" (572 mm), 34-1/2" (876 mm) and 46-1/2" (1181 mm) net section lengths are available (see **Tables on this page** and **Pages 35 and 36 - Vent Sections**). Plan the vent lengths so that a joint does not occur at the intersection of ceiling or roof joists. Refer to the Vent Section Length Chart.

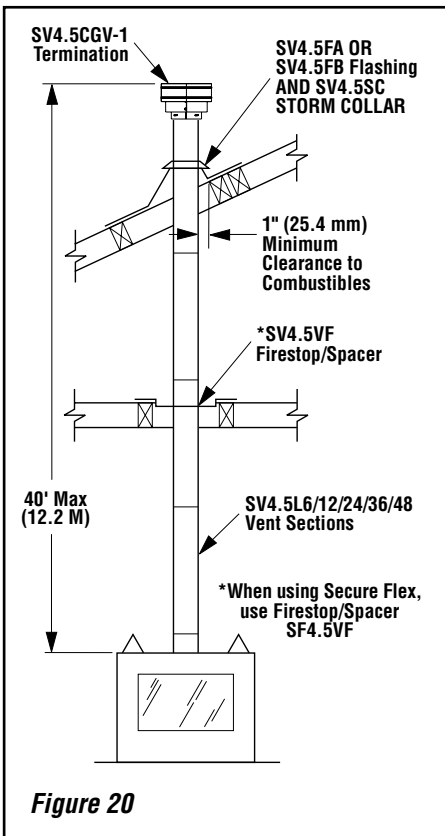

Figure 20

VENT SECTION LENGTH CHART							T O T A L Q U A N T I T Y
Nominal Section Length (inches)	6	12	24	36	48		
Net Section Length (inches)	4-1/2	10-1/2	22-1/2	34-1/2	46-1/2		
Height of Vent	Number of Vent Sections						
inches	ft						
4.5	0.375	1	0	0	0	0	1
9	0.75	2	0	0	0	0	2
10.5	0.875	0	1	0	0	0	1
15	1.25	1	1	0	0	0	2
19.5	1.625	2	1	0	0	0	3
21	1.75	0	2	0	0	0	2
22.5	1.875	0	0	1	0	0	1
25.5	2.125	1	2	0	0	0	3
31.5	2.625	0	3	0	0	0	3
34.5	2.875	0	0	0	1	0	1
37.5	3.125	1	1	1	0	0	3
43.5	3.625	0	2	1	0	0	3
45	3.75	0	0	2	0	0	2
46.5	3.875	0	0	0	0	1	1
49.5	4.125	1	0	2	0	0	3
51	4.25	1	0	0	0	1	2
55.5	4.625	0	1	2	0	0	3
57	4.75	0	0	1	1	0	2
66	5.25	0	2	2	0	0	4
67.5	5.625	0	0	3	0	0	3
69	5.75	0	0	0	2	0	2
72	6	1	0	3	0	0	4
73.5	6.125	1	0	0	2	0	3
79.5	6.625	0	1	0	2	0	3
81	6.75	0	0	0	1	1	2
90	7.5	0	2	1	0	1	4
91.5	7.625	0	0	2	0	1	3
93	7.75	0	0	0	0	2	2
96	8	1	0	1	2	0	4
97.5	8.125	1	0	0	0	2	3
102	8.5	2	0	0	0	2	4
103.5	8.625	0	0	0	3	0	3
108	9	1	0	0	3	0	4
114	9.5	0	2	0	0	2	4
117	9.75	1	0	5	0	0	6
118.5	9.875	1	1	0	3	0	5
126	10.5	0	0	1	3	0	4
130.5	10.875	1	0	1	3	0	5
135	11.25	0	0	6	0	0	6
138	11.5	0	0	0	4	0	4
139.5	11.625	0	0	0	0	3	3
142.5	11.875	1	0	0	4	0	5

Note: Convert inches into metric equivalent measurement, as follows:
Millimeters (mm) = Inches x 25.4
Centimeters (cm) = Inches x 2.54
Meters (M) = Inches x .0254

VENT SECTION LENGTH CHART							T O T A L Q U A N T I T Y
Nominal Section Length (inches)	6	12	24	36	48		
Net Section Length (inches)	4-1/2	10-1/2	22-1/2	34-1/2	46-1/2		
Height of Vent	Number of Vent Sections						
inches	ft						
144	12	1	0	0	0	3	4
150	12.5	0	1	0	0	3	4
154.5	12.875	1	1	0	0	3	5
160.5	13.375	0	2	0	0	3	5
172.5	14.375	0	0	0	5	0	5
177	14.75	1	0	0	5	0	6
183	15.25	0	1	0	5	0	6
186	15.5	0	0	0	0	4	4
190.5	15.875	1	0	0	0	4	5
196.5	16.375	0	1	0	0	4	5
205.5	17.125	0	1	1	5	0	7
207	17.25	0	0	0	6	0	6
211.5	17.625	1	0	0	6	0	7
217.5	18.125	0	1	0	6	0	7
229.5	19.125	0	0	1	6	0	7
232.5	19.375	0	0	0	0	5	5
237	19.75	1	0	0	0	5	6
241.5	20.125	0	0	0	7	0	7
246	20.5	1	0	0	7	0	8
252	21	0	1	0	7	0	8
264	22	0	0	1	7	0	8
276	23	0	0	0	8	0	8
279	23.25	0	0	0	0	6	6
280.5	23.375	1	0	0	8	0	9
283.5	23.625	1	0	0	0	6	7
289.5	24.125	0	1	0	0	6	7
301.5	25.125	0	0	1	0	6	7
310.5	25.875	0	0	0	9	0	9
315	26.5	1	0	0	9	0	10
325.5	27.125	0	0	0	0	7	7
330	27.5	1	0	0	0	7	8
336	28	0	1	0	0	7	8
345	28.75	0	0	0	10	0	10
349.5	29.125	1	0	0	10	0	11
372	31	0	0	0	0	8	8
376.5	31.375	1	0	0	0	8	9
379.5	31.625	0	0	0	11	0	11
418.5	34.875	0	0	0	0	9	9
423	35.25	1	0	0	0	9	10
465	38.75	0	0	0	0	10	10

Effective Vent Length	
Model	Effective Length
SV4.5L6	4-1/2"
SV4.5L12	10-1/2"
SV4.5L24	22-1/2"
SV4.5L36	34-1/2"
SV4.5L48	46-1/2"

Table 7

Vertical (Offset) Installation

Analyze the vent routing and determine the quantities of vent sections and number of elbows required. Refer to **Vertical Vent Figures and Tables on page 14** to select the type of vertical installation desired. Vent sections are available in net lengths of 4-1/2" (114 mm), 10-1/2" (267 mm), 22-1/2" (572 mm), 34-1/2" (876 mm) and 46-1/2" (1181 mm). Refer to the **Vent Section Length Chart on page 14** for an aid in selecting length combinations. Elbows are available in 90° and 45° configurations. Refer to **Figure 25** for the SV4.5E45 and SV4.5E90 elbow dimensional specifications.

Where required, a **telescopic vent section (SV4.5LA)** may be used to provide the installer with an option in installing in tight and confined spaces or where the vent run made up of fixed length pieces develops a joint in a undesirable location, or will not build up to the required length. The SV4.5LA Telescopic Vent Section has an effective length of from 1-1/2" (38 mm) to 7-1/2" (191 mm). The SV4.5LA is fitted with a locking inclined channel end (identical to a normal vent section component) and a plain end with 3 pilot holes. Slip the plain end over the locking channel end of a standard SV4.5 vent component the required distance and secure with three screws.

Maintain a minimum 1" (25 mm) clearance to combustible materials for all vertical elements. Clearances for all horizontal elements are 3" (76 mm) on top, 1" (25 mm) on sides and 1" (25 mm) on the bottom.

A. Frame ceiling opening - Use a plumb line from the ceiling above the appliance to locate center of the vertical run. Cut and/or frame an opening, 10-1/2" x 10-1/2" (267mm x 267mm) inside dimensions, about this center mark (**Figure 21**).

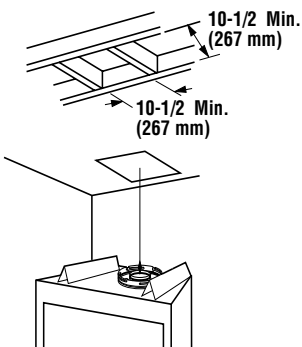

Figure 21

B. Attach vent components to appliance - Secure Vent SV4.5 direct vent system components are unitized concentric pipe components featuring positive twist lock connections (see **Figure 19**).

All of the appliances covered in this document are fitted with collars having locking inclined channels. The dimpled end of the vent components fit over the appliance collar to create the positive twist lock connection.

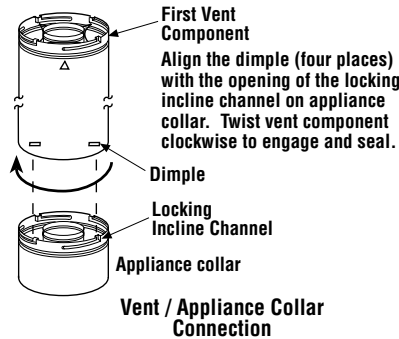

Figure 22

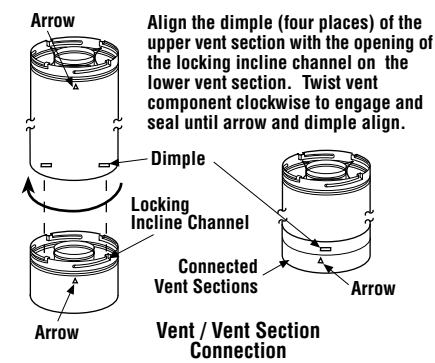

Figure 23

To attach a vent component to the appliance collar, align the dimpled end over the collar, adjusting the radial alignment until the four locking dimples are aligned with the inlet of the four inclined channels on the collar (refer to **Figure 22**). Push the vent component against the collar until it fully engages, then twist the component clockwise, running the dimples down and along the incline channels until they seat at the end of the channels. The unitized design of the **Secure Vent** components will engage and seal both the inner and outer pipe without the need for sealant or screws. If desired a #6 x 1/2" screw may be used at the joint, but it is not required as the pipe will securely lock when twisted.

Note: An elbow may also be attached to the appliance collar. Attach in the same manner as you would a vent section.

C. Attach vent components to each other - Other vent sections may be added to the previously installed section in accordance with the requirements of the vertical vent figures and tables. To add another vent component to a length of vent run, align the dimpled end over the inclined channel end of the previously installed section, adjusting the radial alignment until the four locking dimples are aligned with the inlets of the four incline channels of the previous section.

Push the vent component against the previous section until it fully engages, then twist the component clockwise running the dimples down and along the incline channels until they seat at the end of the channels. **This seating position is indicated by the alignment of the arrow and dimple as shown in Figure 23.**

D. Install firestop/spacer at ceiling - When using Secure Vent, use SV4.5VF firestop/spacer at ceiling joists; when using Secure Flex, use SF4.5VF firestop/spacer. If there is living space above the ceiling level, the firestop/spacer must be installed on the bottom side of the ceiling. If attic space is above the ceiling, the firestop/spacer must be installed on the top side of the joist. Route the vent sections through the framed opening and secure the firestop/spacer with 8d nails or other appropriate fasteners at each corner. **Remember to maintain 1" (25 mm) clearance to combustibles, framing members, and attic or ceiling insulation when running vertical chimney sections. Attic insulation shield (96K94) may be used to obtain the required clearances indicated here. See installation accessories table on pages 35 and 36.**

E. Support the vertical vent run sections - **Note** - Proper venting support is very important. The weight of the vent must not be supported by the fireplace in any degree.

Support the vertical portion of the venting system every 8 feet (2.4m) above the fireplace vent outlet. One method of support is by utilizing field provided support straps (conventional plumber's tape). Secure the plumber's tape to the framing members with nails or screws. Loop the tape around the vent, securing the ends of the tape to the framing. If desired, sheet metal screws #6 x 1/2" length may be used to secure the support straps to the vent pipe. See **Figure 24**.

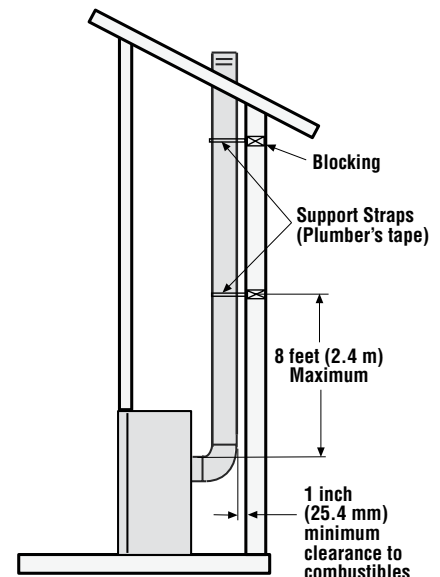

Figure 24

NOTE: DIAGRAMS & ILLUSTRATIONS ARE NOT TO SCALE.

F. Change vent direction to horizontal/inclined run - At transition from or to a horizontal/inclined run, install the SV4.5E45 and SV4.5E90 elbows in the same manner as the straight vent sections. The elbows feature a twist section to allow them to be routed about the center axis of their initial collar section to align with the required direction of the next vent run element. **Twist elbow sections in a clockwise direction only so as to avoid the possibility of unlocking any of the previously connected vent sections.** See **Figure 25**.

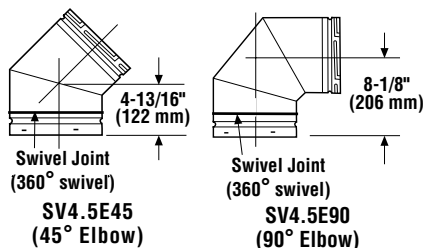
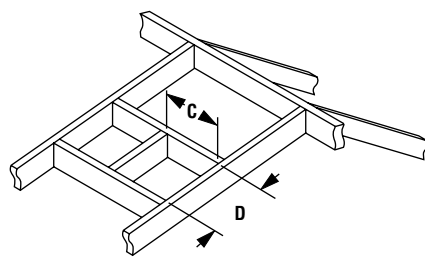

Figure 25

G. Continue installation of horizontal/inclined sections - Continue with the installation of the straight vent sections in horizontal/inclined run as described in **Step C**. Install support straps every 5' (1.52 m) along horizontal/inclined vent runs using conventional plumber's tape. **It is very important that the horizontal/inclined run be maintained in a straight (no dips) and slightly elevated plane in a direction away from the fireplace 1/4" per foot (20 mm per meter) of horizontal vent.** Use a carpenter's level to measure from a constant surface and adjust the support straps as necessary.

It is important to maintain the required clearances to combustibles: 1" (25 mm) at all sides for all vertical runs; and 3" (76 mm) at the top, 1" (25 mm) at sides, and 1" (25 mm) at the bottom for all horizontal/inclined runs.

H. Frame roof opening - Identify location for vent at the roof. Cut and/or frame opening per Roof Framing Chart and **Figure 26**.



Framing Dimensions for Roof

Pitch	C	D
0/12	10-1/2 in. (267 mm)	10-1/2 in. (267 mm)
6/12	10-1/2 in. (267 mm)	12 in. (305 mm)
12/12	10-1/2 in. (267 mm)	17-3/4 in. (451 mm)

Figure 26

I. Install the roof flashing - Extend the vent sections through the roof structure. Install the roof flashing over the vent section and position such that the vent column rises vertically (use carpenter's level) (**Figure 27**). Nail along perimeter to secure flashing or adjust roofing to overlap the flashing edges at top and sides only and trim where necessary. Seal the top and both sides of the flashing with waterproof caulking.

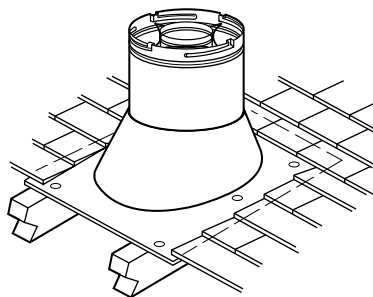

Figure 27

J. Install the storm collar - Install the storm collar, supplied with the flashing, over the vent/flashing joint. See **Figure 28**. Loosen the storm collar screw. Slide collar down until it meets the top of the flashing. Tighten the adjusting screw. Apply non-combustible caulking or mastic around the circumference of the joint to provide a water tight seal.

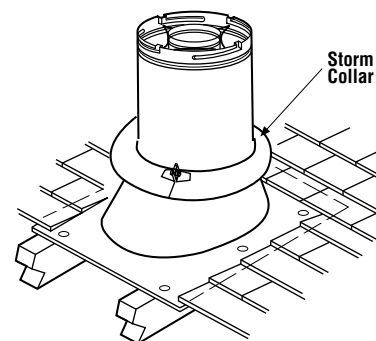

Figure 28

K. Install the vertical termination - The final step involves installation of the SV4.5CGV-1 Vertical Termination. Extend the vent sections to the height as shown in the "Vertical vent termination section" on **page 5**. The SV4.5CGV-1 Vertical Termination (**Figure 29**) installs in the exact same fashion as any other **Secure Vent** section. Align the termination over the end of the previously installed section, adjusting the radial alignment until the four locking dimples of the termination are aligned with the inlets of the four incline channels of the last vent section. Push the termination down until it fully engages, then twist the termination clockwise running the dimples down and along the incline channels until they seat at the end of the channels.

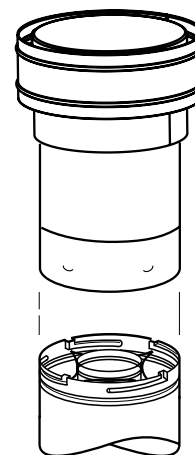

Figure 29

If the vent system extends more than 5' (1.5 m) above the roof flashing, stabilizers may be necessary. Additional screws may be used at section joints for added stability. Guide wires may be attached to the joint for additional support on multiple joint configurations.

VERTICAL VENT FIGURES/TABLES

Note: *Secure Vent* (rigid vent pipe) is shown in the figures; *Secure Flex* (flexible vent pipe) may also be used.

Note: It is very important that the horizontal/inclined run be maintained in a straight (no dips) and recommended to be in a slightly elevated plane, in a direction away from the fireplace of 1/4" rise per foot (20 mm per meter) which is ideal, though rise per foot run ratios that are smaller are acceptable all the way down to at or near level.

Note: SV4.5VF (*Secure Vent*), SF4.5VF (*Secure Flex*) firestop/spacer must be used anytime vent pipe passes through a combustible floor or ceiling. SV4.5HF (*Secure Vent*), SF4.5HF (*Secure Flex*) firestop/spacer must be used anytime vent pipe passes through a combustible wall.

Note: Two 45 degree elbows may be used in place of one 90 degree elbow. The same rise to run ratios, as shown in the venting figures for 90 elbows, must be followed if 45 degree elbows are used.

Note: An elbow is acceptable as 1 foot of vertical rise, except where an elbow is the only vertical component in the system. (See Figure 39 on page 21).

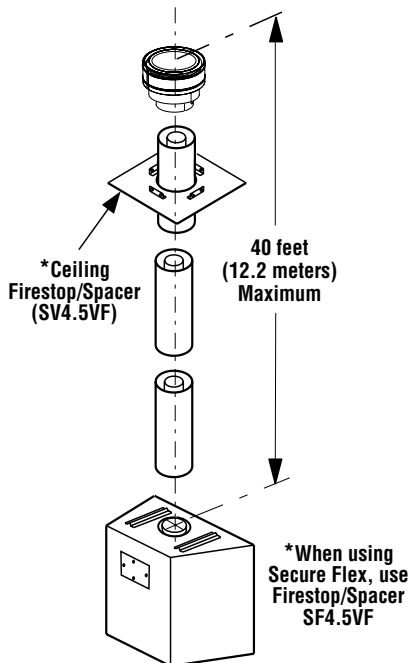

A Vent Restrictor, as shown in Figure 18 on Page 13, must be used in this application.

Figure 30 - Top Vent - STRAIGHT

TABLE A			
H Maximum		V Minimum	
feet	(meters)	feet	(meters)
2	(0.610)	1	(0.305)
4	(1.219)	2	(0.610)
6	(1.829)	3	(0.914)
8	(2.438)	4	(1.219)
V + H = 40 feet (12.2 meters) Max. H = 8 feet (2.4 meters) Max. Ratio V to H ratio is 1:2			

Example: If 8 feet of (H) horizontal vent run is needed, then 4 feet minimum (V) vertical vent will be required.

This table shows a 1 (V) to 2 (H) ratio. For every 1 foot of (V) vertical, you are allowed 2 feet of (H) horizontal run, up to a maximum horizontal run of 8 feet.

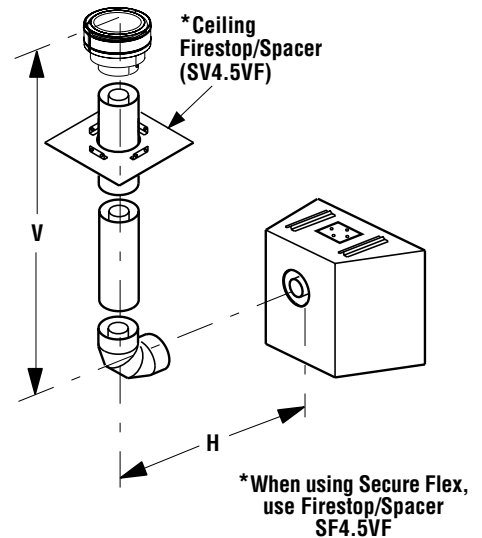

Figure 31 - Rear Vent - ONE 90 DEGREE ELBOW

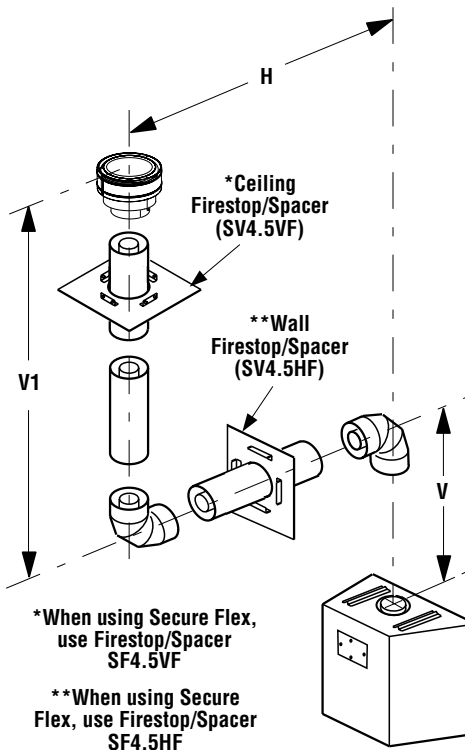

TABLE B			
H Maximum		V Minimum	
feet	(meters)	feet	(meters)
5	(1.524)	Elbow Only	
5	(1.524)	1	(0.305)
10	(3.048)	2	(0.610)
15	(4.572)	3	(0.914)
20	(6.096)	4	(1.219)
V + V ₁ + H = 40 feet (12.2 m) Max. H = 20 feet (6.096 meters) Max.			

Example: If 20 feet of (H) horizontal vent run is needed, then 4 feet minimum of (V) vertical vent will be required.

This table shows a 1 (V) to 5 (H) ratio. For every 1 foot of (V) vertical, you are allowed 5 feet of (H) horizontal run, up to a maximum horizontal run of 20 feet.

An elbow is acceptable as 1 foot of vertical rise except where an elbow is the only vertical component in the system. See Figure 39.

Figure 32 - Top Vent - TWO 90 DEGREE ELBOWS

WARNING

Under no circumstances, may separate sections of concentric flexible vent pipe be joined together.

NOTE: DIAGRAMS & ILLUSTRATIONS ARE NOT TO SCALE.

VERTICAL VENT FIGURES/TABLES
(continued)

TABLE C					
H+H ₁ Maximum		H Maximum		V Minimum	
feet	(meters)	feet	(meters)	feet	(meters)
5	(1.524)	2	(0.610)	1	(0.305)
10	(3.048)	4	(1.219)	2	(0.610)
15	(4.572)	6	(1.829)	3	(0.914)
20	(6.096)	8	(2.438)	4	(1.219)

V + V₁ + H + H₁ = 40 feet (12.2 m) Max
H = 8 feet (2.438 meters) Max.
H + H₁ = 20 feet (6.096 meters) Max.

Example: If 20 feet of (H) horizontal vent run is needed, then 4 feet minimum of (V) vertical vent will be required.

This table shows a 1 (V) to 5 (H) ratio. For every 1 foot of (V) vertical, you are allowed 5 feet of (H) horizontal run, up to a maximum horizontal run of 20 feet.

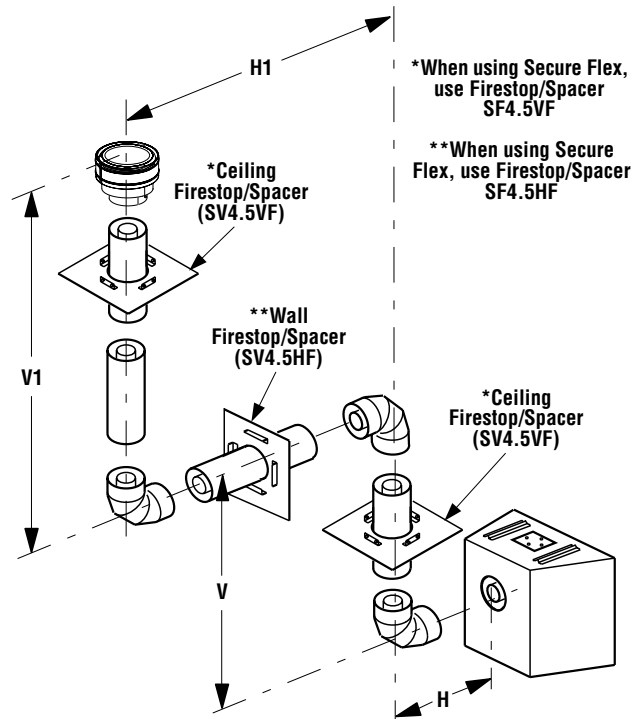

Figure 33 - Rear Vent - THREE ELBOWS

TABLE D			
H + H ₁ Maximum		V Minimum	
feet	(meters)	feet	(meters)
5	(1.524)	Elbow Only	
5	(1.524)	1	(0.305)
10	(3.048)	2	(0.610)
15	(4.572)	3	(0.914)
20	(6.096)	4	(1.219)

H + H₁ = 20 feet (6.096 m) Max.
V + V₁ + H + H₁ = 40 ft. (12.192 m) Max.

Example: If 20 feet of (H) horizontal vent run is needed, then 4 feet minimum of (V) vertical vent will be required.

This table shows a 1 (V) to 5 (H) ratio. For every 1 foot of (V) vertical, you are allowed 5 feet of (H) horizontal run, up to a maximum horizontal run of 20 feet.

An elbow is acceptable as 1 foot of vertical rise except where an elbow is the only vertical component in the system. See **Figure 39**.

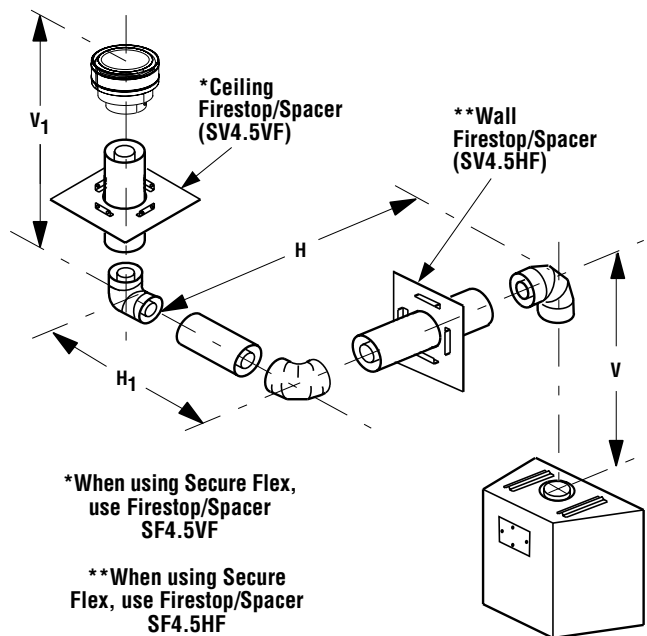

Figure 34 - Top Vent - THREE ELBOWS

HORIZONTAL (OUTSIDE WALL) TERMINATION SYSTEM

Figures 35, and Figures 39 to 44 on pages 21 to 23 and their associated Horizontal Vent Table illustrate the various horizontal venting configurations that are possible for use with these appliances. **Secure Vent** pipe applications are shown in these figures; **Secure Flex** pipe may also be used. A Horizontal Vent Table summarizes each system's minimum and maximum vertical and horizontal length values that can be used to design and install the vent components in a variety of applications.

Both of these horizontal vent systems terminate through an outside wall. Building Codes limit or prohibit terminating in specific areas. Refer to **Figure 8 on page 7** for location guidelines.

Secure Vent SV4.5 direct vent system components are unitized concentric pipe components featuring positive twist lock connection, (refer to **Figure 22 on page 15**). All of the appliances covered in this document are fitted with collars having locking inclined channels. The dimpled end of the vent components fit over the appliance collar to create the positive twist lock connection.

A. Plan the vent run -

Analyze the vent routing and determine the types and quantities of sections required 4-1/2" (114 mm), 10-1/2" (267 mm), 22-1/2" (572 mm), 34-1/2" (876 mm) and 46-1/2" (1181 mm) net section lengths are available. It is recommended that you plan the venting so that a joint does not occur in the ceiling or roof joists. Allow for elbows as indicated in **Figure 25 on page 16**.

Maintain a minimum 1" (25 mm) clearance to combustibles on the vertical sections. Clearances for the horizontal runs are: 3" (76 mm) on top, 1" (25 mm) on sides, and 1" (25 mm) at the bottom.

B. Frame exterior wall opening -

Locate the center of the vent outlet on the exterior wall according to the dimensions shown in **Figure 9 on page 8**. Cut and/or frame an opening, 10-1/2" x 12-1/8" (267 mm x 308mm) inside dimensions, about this center.

C. Frame ceiling opening - If the vertical route is to penetrate a ceiling, use plumb line to locate the center above the appliance. Cut and/or frame an opening, 10-1/2" x 10-1/2" (267 mm x 267 mm) inside dimensions, about this center (refer to **Figure 21 on page 15**).

D. Attach vent components to appliance - To attach a vent component to the appliance collar, align the dimpled end over the collar, adjusting the radial alignment until the four locking dimples are aligned with the inlets of the four incline channels on the collar (refer to **Figure 22 on page 15**).

Push the vent component against the collar until it fully engages, then twist the component clockwise, running the dimples down and along the incline channels until they seat at the end of the channels.

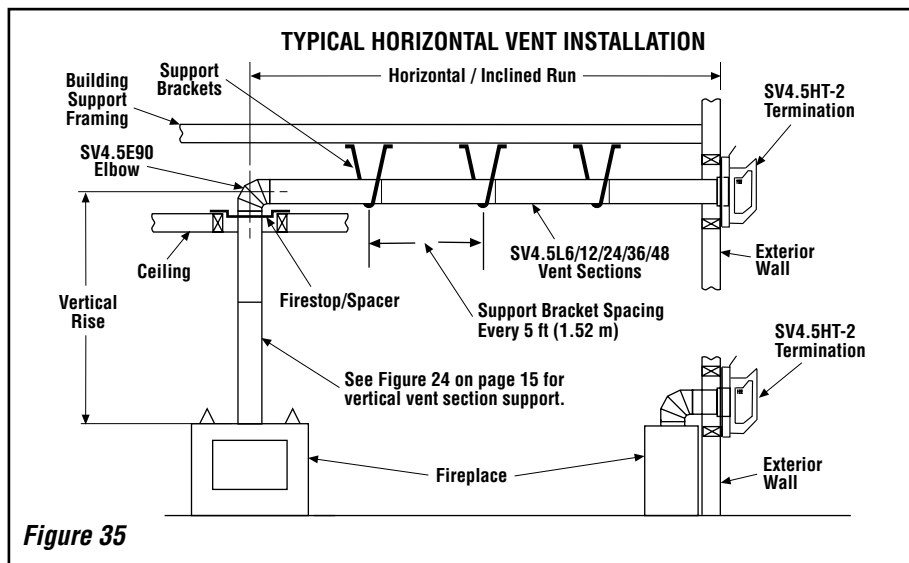

Figure 35

The unitized design of the **Secure Vent** components will engage and seal both the inner and outer pipe elements with the same procedure. Sealant and securing screws are not required.

Note: An elbow may also be attached to the appliance collar. Attach in the same manner as you would a vent section.

E. Attach vent components to each other - Other vent sections may be added to the previously installed section in accordance with the requirements of the vent tables. To add another vent component to a length of vent run, align the dimpled end of the component over the inclined channel end of the previously installed section, adjusting the radial alignment until the four locking dimples are aligned with the inlets of the four incline channels of the previous section. Push the vent component against the previous section until it fully engages, then twist the component clockwise running the dimples down and along the incline channels until they seat at the end of the channels. **This seating position is indicated by the alignment of the arrow and dimple as shown in Figure 23 on page 15.**

F. Install firestop/spacer at ceiling -

When using **Secure Vent**, use SV4.5VF firestop/spacer at ceiling joists; when using **Secure Flex**, use SF4.5VF firestop/spacer. If there is living space above the ceiling level, the firestop/spacer must be installed on the bottom side of the ceiling. If attic space is above the ceiling, the firestop/spacer must be installed on the top side of the joist. Route the vent sections through the framed opening and secure the firestop/spacer with 8d nails or other appropriate fasteners at each corner.

Remember to maintain 1" (25 mm) clearance to combustibles, framing members, and attic or ceiling insulation when running vertical chimney sections.

G. Support the vertical run sections -

On the vertical run, support the venting system every 8 feet (2.4m) above the fireplace vent outlet with field provided support straps (Plumber's tape). Attach the straps to the vent pipe and secure to the framing members with nails or screws. See **Figure 24 on page 15**.

H. Change vent direction - At transition from or to a horizontal/inclined run, install the SV4.5E45 and SV4.5E90 elbows in the same manner as the straight vent sections. The elbows feature a twist section to allow them to be routed about the center axis of their initial collar section to align with the required direction of the next vent run element. **Twist elbow sections in a clockwise direction only so as to avoid the possibility of unlocking any of the previously connected vent sections.** See **Figure 25 on page 16**.

I. Continue installation of horizontal/inclined sections - Continue with the installation of the straight vent sections in horizontal/inclined run as described in **Step E**. Install support straps every 5 ft. (1.52 m) along horizontal/inclined vent runs using conventional plumber's tape. See **Figure 35**, it is very important that the horizontal/inclined run be maintained in a straight (no dips) and recommended to be in a slightly elevated plane, in a direction away from the fireplace of 1/4" rise per foot (20 mm per meter) which is ideal, though rise per foot run ratios that are smaller are acceptable all the way down to at or near level. Use a carpenter's level to measure from a constant surface and adjust the support straps as necessary.

It is important to maintain the required clearances to combustibles: 1" (25 mm) at all sides for all vertical runs; and 3" (76 mm) at the top, 1" (25 mm) at sides, and 1" (25 mm) at the bottom for all horizontal/inclined runs

J. Assemble vent run to exterior wall - If not previously measured, locate the center of the vent at the exterior wall. Prepare an opening as described in **Step B**. Assemble the vent system to point where the terminus of the last section is within 7 in. (178 mm) to 11-1/4 in. (286 mm) inboard of the exterior surface to which the SV4.5 HT termination is to be attached, see **Figure 37**. If the terminus of the last section is not within this distance, use the **telescopic vent section SV4.5LA**, as the last vent section. For wall thicknesses greater than that shown in **Figure 37**, refer to **Table 8 on page 21**. This table lists the additional venting components needed (in addition to the termination and adapter) for a particular range of wall thicknesses.

K. Attach termination adapter - Attach the adapter (adapter - SV4.5RCH - provided with the termination) to the vent section or telescoping vent section, elbow or appliance collar as shown in **Figure 36** in the same manner as any SV4.5 vent component (refer to **Step E**).

L. Install Firestop/Spacer at exterior wall - When using the **square** termination, install SV4.5HF (Secure Vent), SF4.5HF (Secure Flex) Firestop/Spacer over the opening at the exterior side of the framing, long side up, with the 3 inch spacer clearance at the top as shown in **Figure 36**, and nail into place.

(The Firestop/Spacer may also be installed over the opening at the interior side of the framing.)

M. Install the desired termination -

1. Install the square termination (SV4.5HT-2 or SV4.5HTSS)- For the last step, from outside the exterior wall, slide the collars of the termination onto the adapter (the outer over the outer and the inner inside the inner) until the termination seats against the exterior wall surface to which it will be attached. Orient the housing of the termination with the arrow pointed upwards. Secure the termination to the exterior wall. **The horizontal termination must not be recessed into the exterior wall or siding** by more than the 1-1/4" (32 mm) as shown in **Figure 37**.

SVHRK Snorkel Cap -The snorkel cap is designed to be fitted into a basement window box. The SVHRK cap is for use with flex vent. The vertical distance between the inlet and outlet of the cap is 28 in. (711 mm). pipe.

IMPORTANT: The vent termination is hot while in operation and for a period of time following the use of the fireplace. To prevent contact with hot surfaces, we recommend the use of a Termination Guard. See Page 36. This can be purchased at your local dealer.

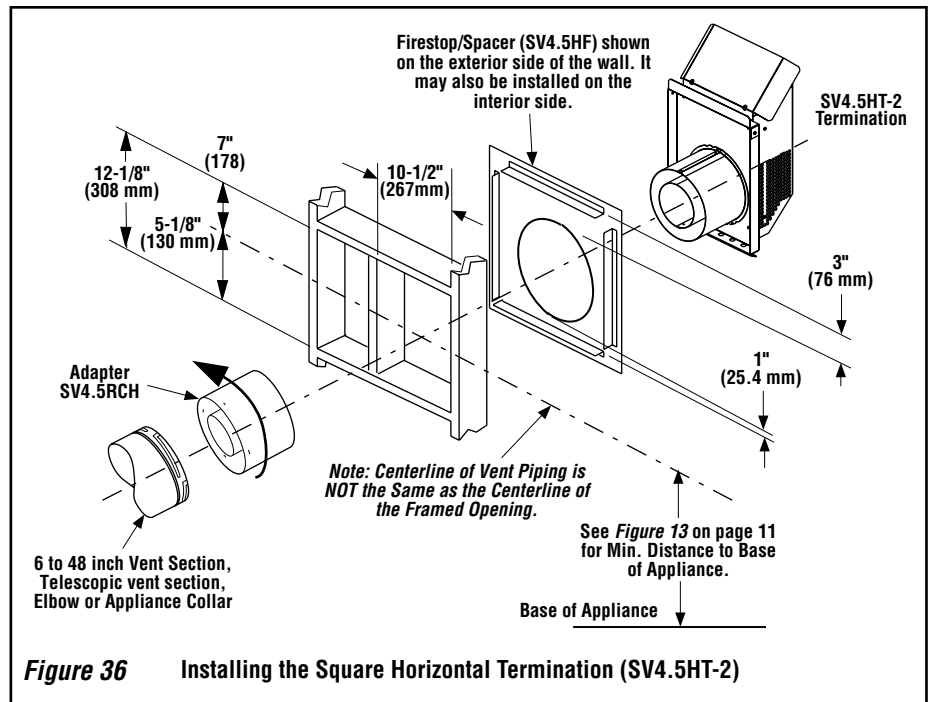

Figure 36 Installing the Square Horizontal Termination (SV4.5HT-2)

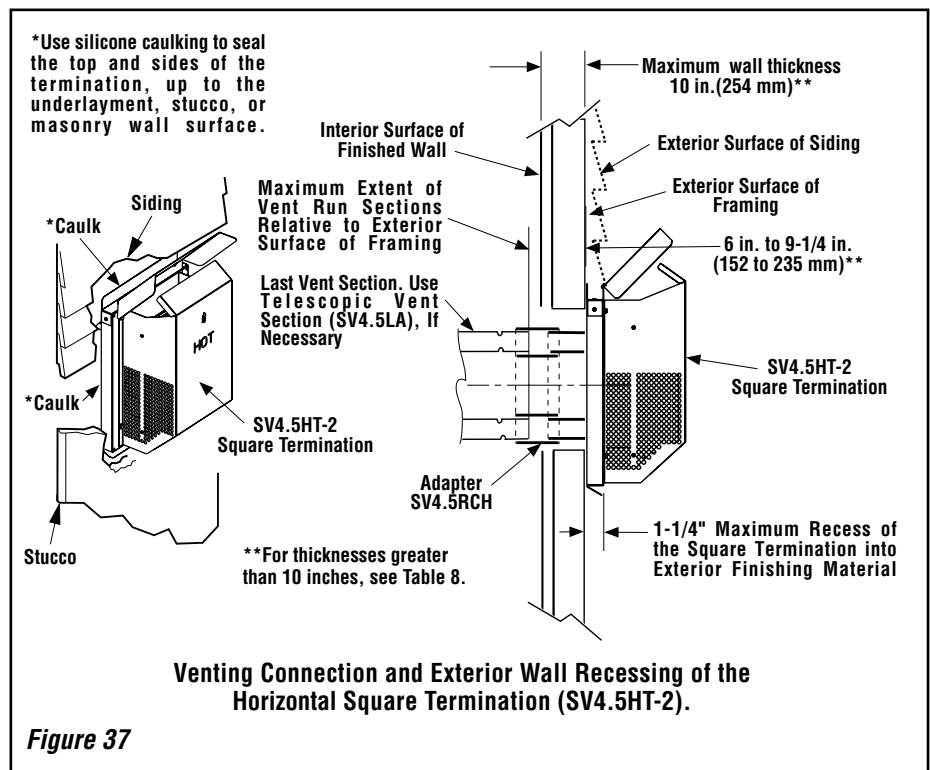

Figure 37

Horizontal terminations have been designed to perform in a wide range of weather conditions. Our terminations meet or exceed industry standards.

When selecting the locations of your horizontal terminations, do not place the termination where water from eaves and adjoining rooflines may create a heavy flow of cascading water onto the termination cap. If the cap must be placed where the possibility of cascading water exists, it is the responsibility of the builder to direct the water away from the termination cap by using gutters or other means.

Take care to carefully follow the installation instructions for the termination, including the use of silicone caulking where required.

NOTE: DIAGRAMS & ILLUSTRATIONS ARE NOT TO SCALE.

HORIZONTAL VENT FIGURES/TABLES

Note: **Secure Vent** components (rigid vent pipe and terminal) are shown in the figures; **Secure Flex** components (flexible vent pipe and terminal) may also be used.

Note: Two 45 degree elbows may be used in place of one 90 degree elbow. The same rise to run ratios, as shown in the venting figures for 90 elbows, must be followed if 45 degree elbows are used.

Note: It is very important that the horizontal/inclined run be maintained in a straight (no dips) and recommended to be in a slightly elevated plane, in a direction away from the fireplace of 1/4" rise per foot (20 mm per meter) which is ideal, though rise per foot run ratios that are smaller are acceptable all the way down to at or near level.

Note: SV4.5VF (Secure Vent), SF4.5VF (Secure Flex) firestop/spacer must be used anytime vent pipe passes through a combustible floor or ceiling. SV4.5HF (Secure Vent), SF4.5HF (Secure Flex) firestop/spacer must be used anytime vent pipe passes through a combustible wall.

! WARNING

Under no circumstances, may separate sections of concentric flexible vent pipe be joined together.

Venting Components Required for Various Exterior Wall Thicknesses, when using Typical Termination Kits	
Vent Components Required	Exterior Wall Thickness - inches (mm)
Termination Kit Only	6 to 9-1/4 (152 to 235)
Termination Kit and 6 In. Vent Section (SV4.5L6)	10-3/4 to 14 (273 to 356)
Termination Kit and 12 in. Vent Section (SV4.5L12)	16-3/4 to 20 (426 to 508)
Termination Kit and Telescopic Section (SV4.5L12)	11-3/4 to 20 (299 to 508)

Table 8 Note: See Figure 37 showing wall thickness range when using SV4.5HT-2 termination kit.

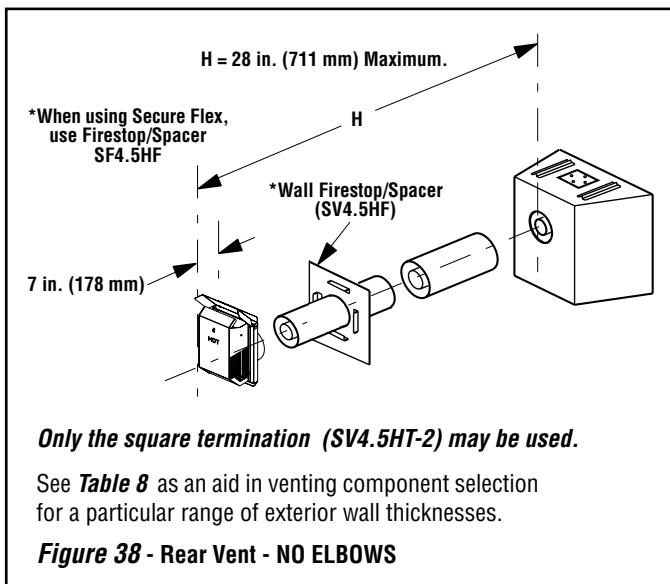
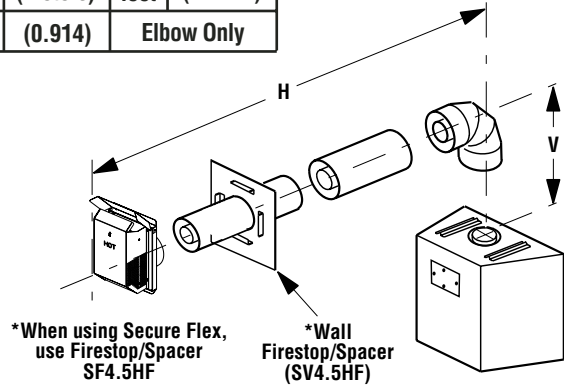

TABLE F			
H Maximum		V Minimum	
feet	(meters)	feet	(meters)
3	(0.914)	Elbow Only	



Square termination (SV4.5HT-2) shown.

See **Table 3** as an aid in venting component selection for a particular range of exterior wall thicknesses.

Figure 39 - Top Vent -

ONE 90 DEGREE ELBOW - ELBOW CONNECTION AT APPLIANCE

TABLE G			
H Maximum		V Minimum	
feet	(meters)	feet	(meters)
5	(1.524)	1	(0.305)
10	(3.048)	2	(0.610)
15	(4.572)	3	(0.914)
20	(6.096)	4	(1.219)
V + H = 40 feet (12.2 m) Max. H = 20 ft. (6.096 m) Max.			

Example: If 20 feet of (H) horizontal vent run is needed, then 4 feet minimum of (V) vertical vent will be required.

This table shows a 1 (V) to 5 (H) ratio. For every 1 foot of (V) vertical, you are allowed 5 feet of (H) horizontal run, up to a maximum horizontal run of 20 feet.

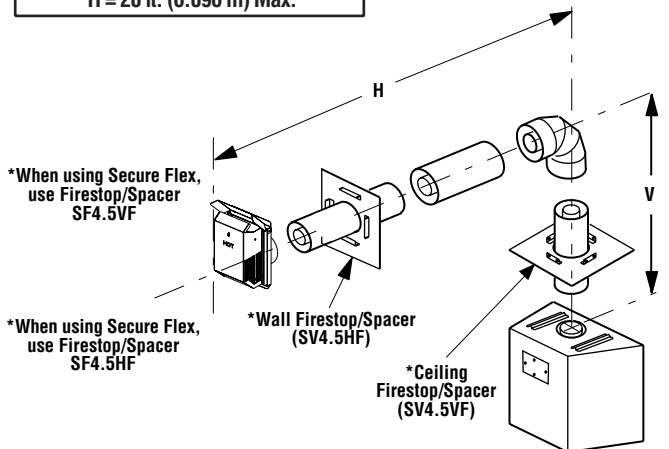

Square termination (SV4.5HT-2) shown.

See **Table 8** as an aid in venting component selection for a particular range of exterior wall thicknesses.

Figure 40 - Top Vent - ONE 90 DEGREE ELBOW - ELBOW CONNECTION NOT DIRECTLY AT APPLIANCE

HORIZONTAL VENT FIGURES/TABLES (continued)

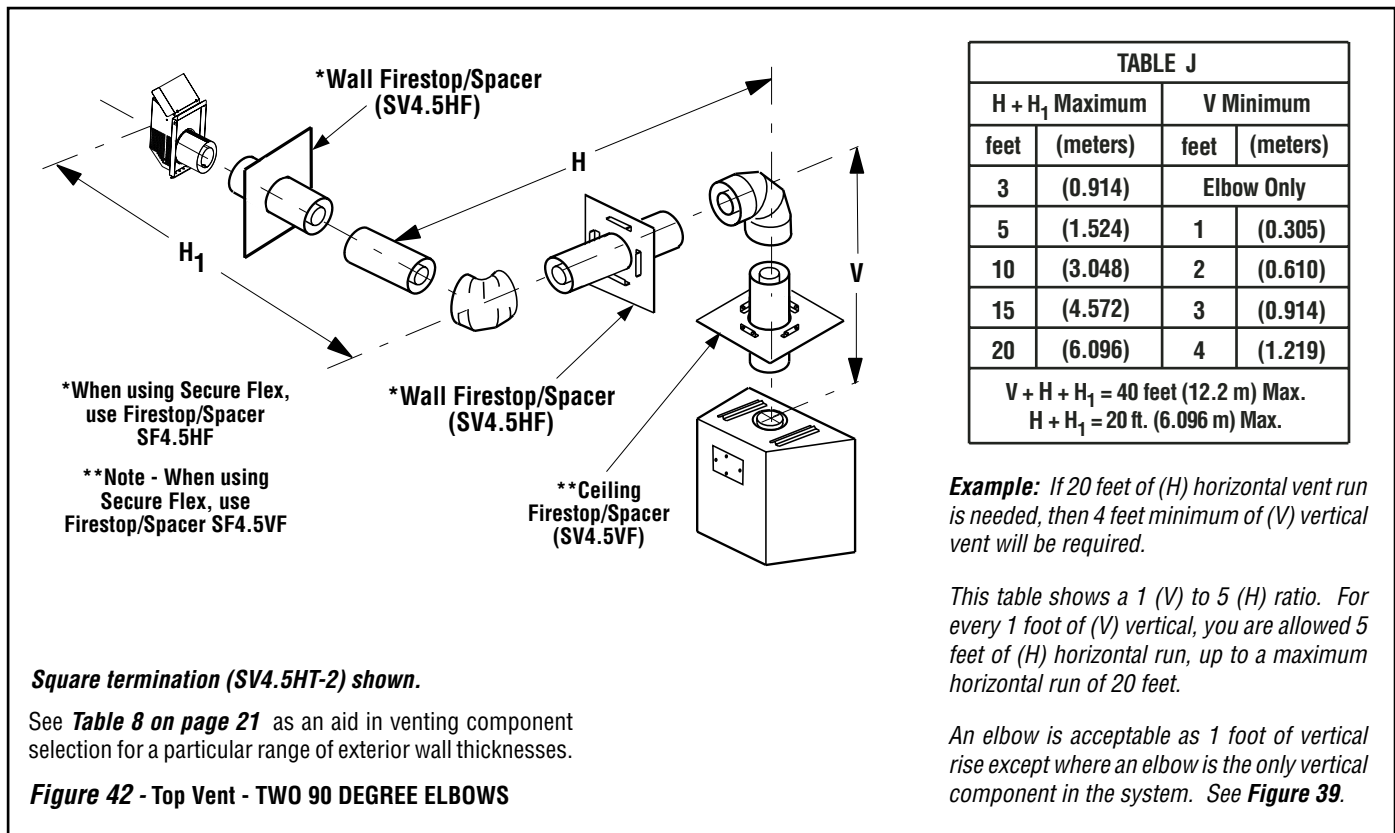
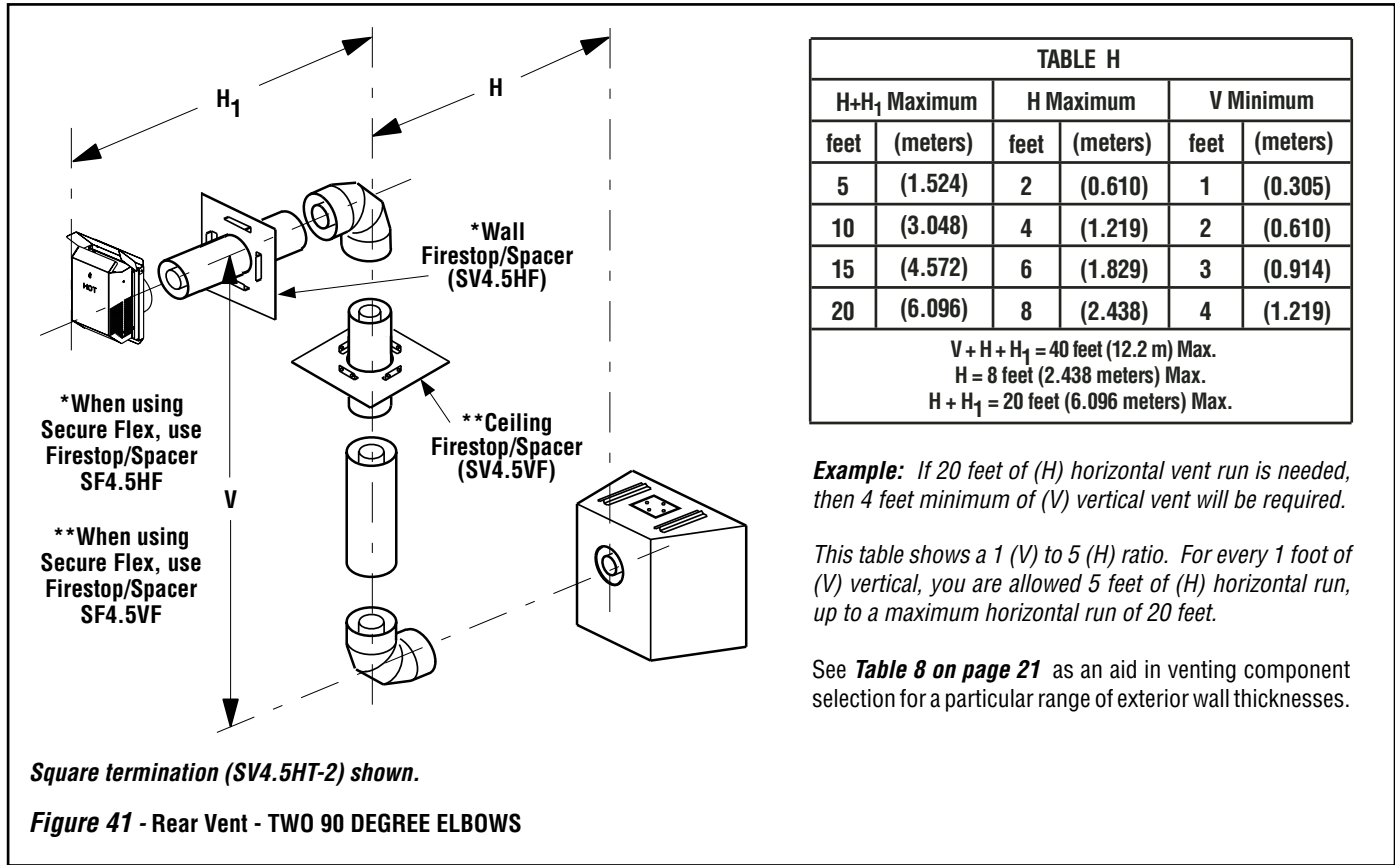

HORIZONTAL VENT FIGURES/TABLES (continued)

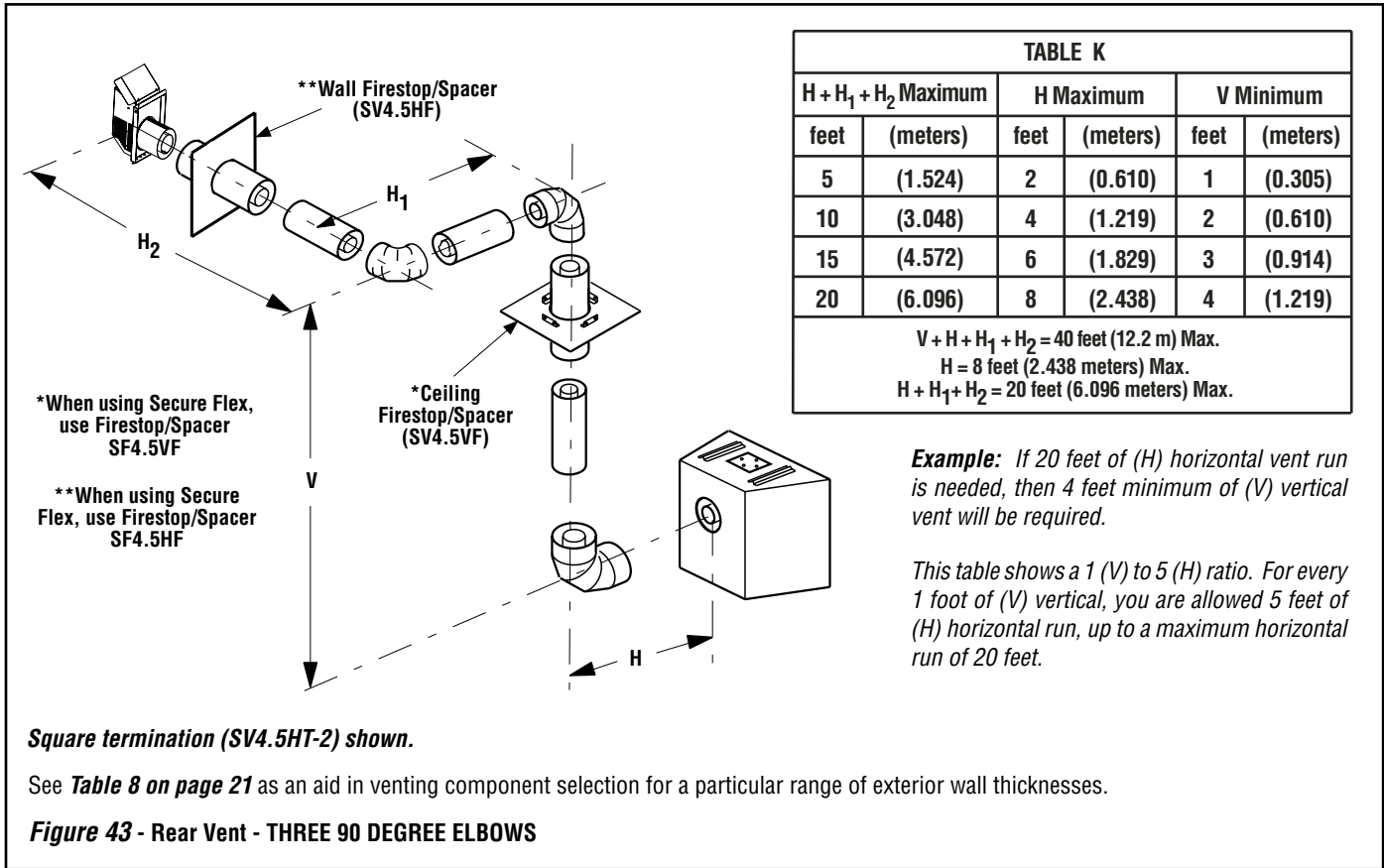

Square termination (SV4.5HT-2) shown.

See **Table 8 on page 21** as an aid in venting component selection for a particular range of exterior wall thicknesses.

Figure 43 - Rear Vent - THREE 90 DEGREE ELBOWS

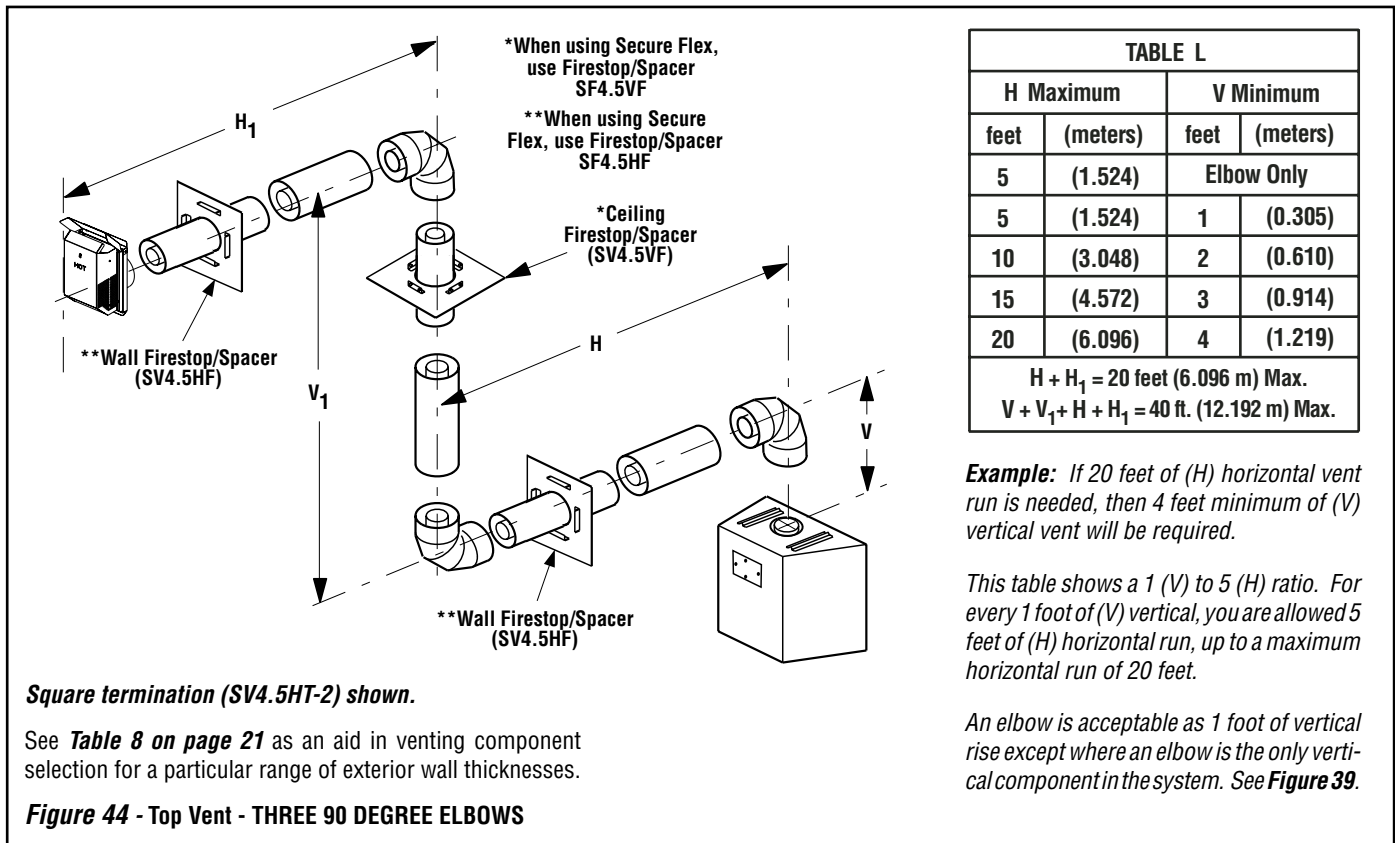

Square termination (SV4.5HT-2) shown.

See **Table 8 on page 21** as an aid in venting component selection for a particular range of exterior wall thicknesses.

Figure 44 - Top Vent - THREE 90 DEGREE ELBOWS

VERTICAL OR HORIZONTAL VENTING USING SECURE FLEX KITS AND COMPONENTS

Secure Flex venting kits and components may be used in any venting application where rigid **Secure Vent** (SV4.5) direct vent components can be used. All restrictions, clearances and allowances that pertain to the rigid piping apply to the flexible venting. **Secure Flex kits may not be modified; also, under no circumstances may separate sections of flex pipe be joined together.** **Secure Flex** kits may be added to the end of a vent run made up of rigid **Secure Vent** (SV4.5) vent sections provided that doing so does not violate any of the venting length, height, routing, horizontal to vertical ratio requirements or clearance considerations detailed in this manual.

Secure Flex kits come with an included adapter that can be fitted to the appliance collar or the inclined channel end of the last **Secure Vent** (SV4.5) vent section in a rigid system in the exact same fashion as any other **Secure Vent** section. Align the dimpled end of the adapter over the previously installed section or appliance collar, adjusting the radial alignment until the four locking dimples of the adapter are aligned with the inlets of the four incline channels of the last vent section or collar. Push on the adapter until it fully engages, then twist the adapter clockwise running the dimples down and along the incline channels until they seat at the end of the channels.

Attach the flexible vent to the adapter as follows (see Figure 45):

A. Install the Inner Flex Pipe -

1. Install the small gear clamp loosely around the inner flexible vent pipe, push it back out of the way.
2. Apply a bead of **Mill-Pac Black (700°F) high temperature sealant - Catalog No. 10K81** to the inner adapter collar, approximately 1/2 inch from the end.
3. Pull and extend the inner flexible vent pipe.
4. Slide the inner flex pipe over the adapter collar. Ensure the flexible vent pipe completely engages the adapter collar to a distance of 1-3/4 inches from the end, and that it is free from damage or tears.
5. Slide the gear clamp down and tighten it fully to secure the flexible vent to the adapter inner collar approximately 3/4 inch from the end of the flex.
6. Install **three screws 120 degrees apart** through the flexible vent pipe and into the adapter collar just below the gear clamp to provide additional security to the connection.

B. Install the Outer Flex Pipe -

1. Install the large gear clamp loosely around the outer flexible vent pipe, push it back out of the way.

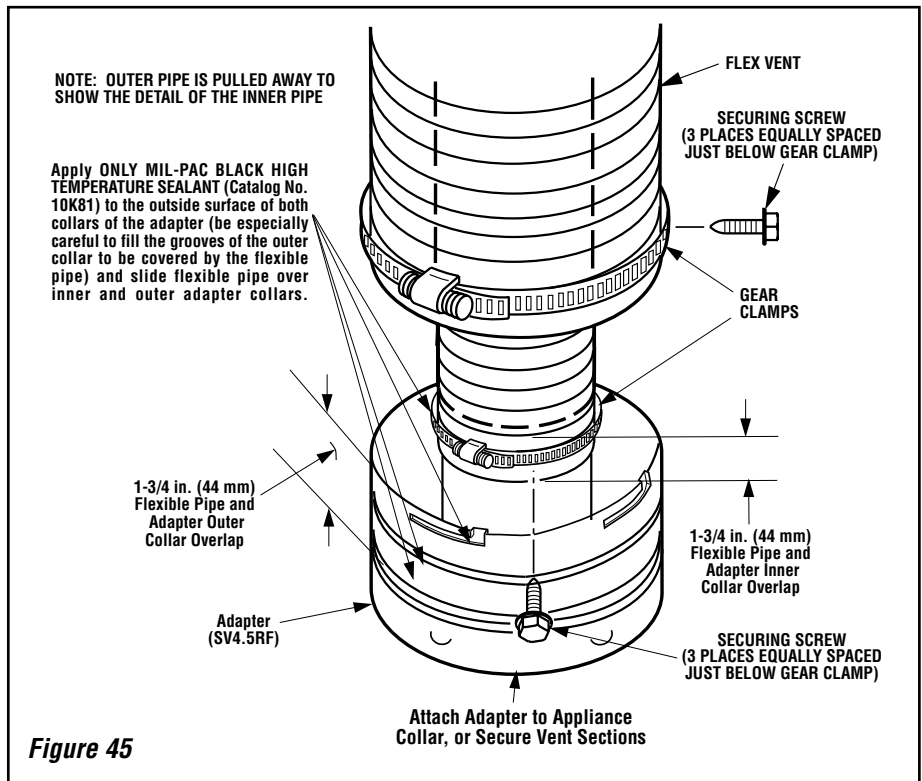

Figure 45

2. Apply a bead of **Mill-Pac Black (700°F) high temperature sealant - Catalog No. 10K81** to the outer adapter collar; to the grooves of the collar which extend approximately 1 inch from the end and to the flat surface, approximately 1-3/8 inches from the end.

3. Pull and extend the outer flexible vent pipe.
4. Slide the outer flex pipe over the adapter collar. Ensure the flexible vent pipe completely engages the adapter collar to a distance of 1 3/4 inches from the end, and that it is free from damage or tears.
5. Slide the gear clamp down and tighten it fully to secure the flexible vent to the adapter outer collar approximately 3/4 inch from the end of the flex.
6. Install **three screws 120 degrees apart** through the flexible vent pipe and into the adapter collar just below the gear clamp to provide additional security to the connection.

C. Route Flex Vent -

Ensure that the flex vent is properly routed to provide the required clearance. Do Not allow the flexible vent to bend in a radius tighter than 5" (127 mm). Refer to **Figure 46**. Support horizontal sections of flex with metal straps at 2 foot (0.61 m) intervals.

D. Install Firestop/Spacers at ceilings and walls -

When **Secure Flex** penetrates a wall or ceiling, a firestop/spacer is required: use the SF4.5 VF firestop/spacer for ceilings and the SF4.5 HF firestop/spacer for walls.

See the appropriate sections and figures shown throughout the venting section for their installation requirements.

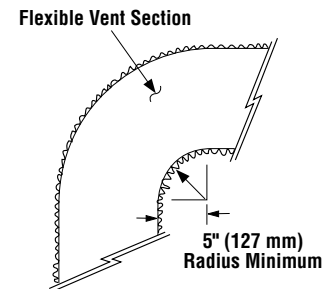

Figure 46

E. Attach Flex Vent to Termination -

Secure Flex components can be purchased separately and attached to bulk lengths of **Secure Flex** flexible tubing cut to size at the job site. Secure the flexible vent to the **Secure Flex** terminations in the same manner (see **Figure 45**) as it was attached to the adapter.

Note: Secure Flex vent must be attached to Secure Flex terminations only. DO NOT substitute Secure Vent terminations or the Secure Vent adapter for Secure Flex components. The collars of Secure Flex terminations and adapters have a different circumference than that used with the Secure Vent pipe. Additionally, Secure Flex components have an extended length center tube for use in attaching the flexible vent.

Step 5. FIELD WIRING

CAUTION

Ground supply lead must be connected to the wire attached to the green ground screw located on the outlet box. See *Figures 48 & 49*. Failure to do so will result in a potential safety hazard. The appliance must be electrically grounded in accordance with local codes or, in the absence of local codes, the National Electrical Code, ANSI/NFPA 70-latest edition. (In Canada, the current CSA C22-1 Canadian Electrical Code).

CAUTION: Label all wires prior to disconnection when servicing controls. Wiring errors can cause improper and dangerous operation.

ATTENTION: Au moment de l'entretien des commandes, étiquetez tous les fils avant de les débrancher. Des erreurs de câblage peuvent entraîner un fonctionnement inadéquat et dangereux.

Verify proper operation after servicing.

S'assurer que l'appareil fonctionne adéquatement une fois l'entretien terminé.

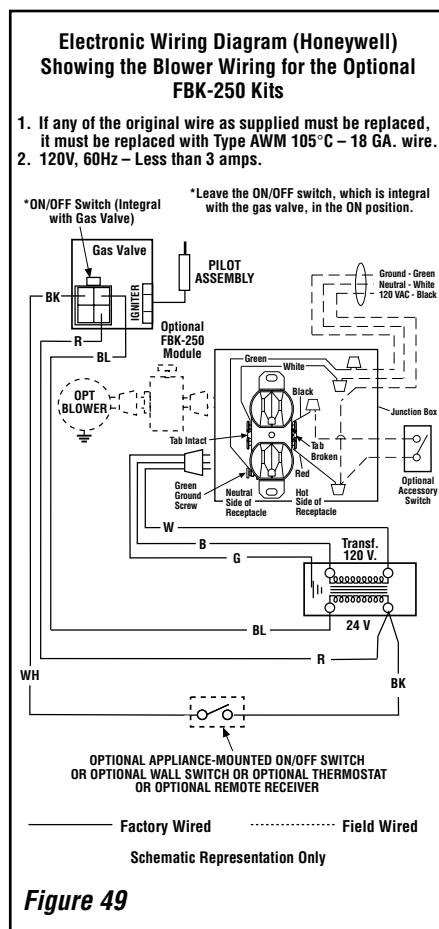
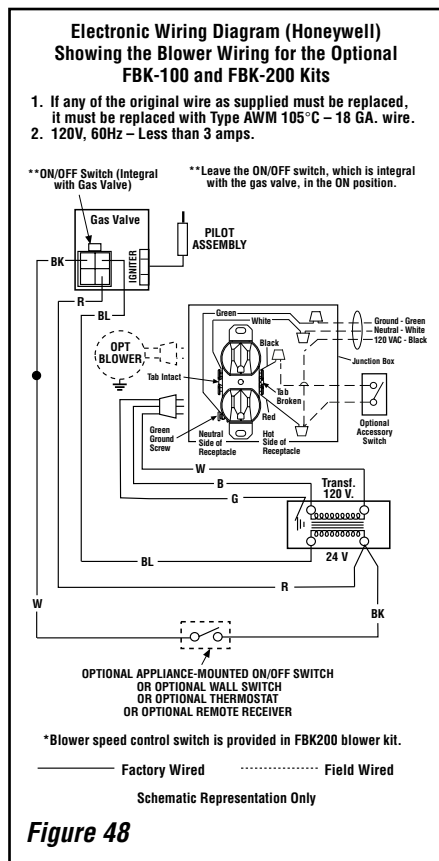
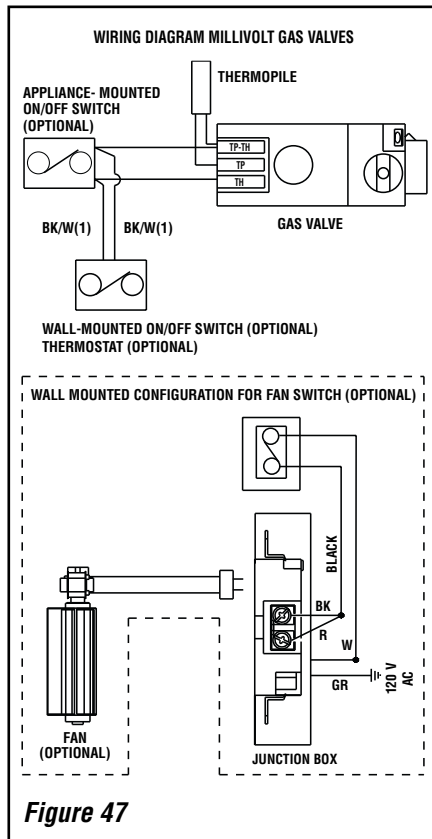

Refer to Section A for millivolt appliances and Section B for electronic appliances. The gas valve is set in place and pre-wired at the factory on both models.

A. Millivolt Wiring (See *Figure 47*) -

1. Appliance-mounted ON/OFF burner control switch (rocker switch) is factory installed in the modesty panel. Optional wall-mounted switch, thermostat, or one of the optional remote control kits may also be used.
2. If wall-mounted ON/OFF control switch thermostat is selected, mount it in a convenient location on a wall near the fireplace.
3. Wire the control switch within the millivolt control circuit using the 15 feet of 2 conductor wire supplied with the unit.

Note: The supplied 15 feet of 2 conductor wire has one end of each conductor connected to the gas valve circuit and the other end of each conductor placed loose inside the bottom compartment.

CAUTION: Do Not connect the optional wall switch to a 120V power supply.

4. If an optional control switch is installed, turn the appliance-mounted ON/OFF burner control switch to the OFF position.

B. Electronic Wiring (See *Figures 48 & 49*) -

Note: The electronic appliance must be connected to the main power supply.

1. Route a 3-wire 120Vac 60Hz 1ph power supply to the appliance junction box.
2. Remove the electrical inlet cover plate from the side of the unit by removing the plate's securing screws (see *Figure 13* on *Page 11*).
3. Remove the cover plate's knockout and then feed the power supply wire through the knockout opening and into the unit junction box.
4. Connect the black power supply wire to the **lower outlet's** red pigtail lead and the white power supply wire to the **common** terminal of the outlet as shown in *Figures 48 & 49*.
5. **Connect the ground supply wire to the pigtail lead attached to outlet's green ground screw.**
6. Appliance-mounted ON/OFF burner control switch (rocker switch) is factory installed in the modesty panel.

Optional wall-mounted switch, thermostat, or one of the optional remote control kits may also be used. The appliance mounted ON/OFF switch needs to be relocated onto the optional style view door, if used.

Note: Remote receiver should be located in the wall, or if installed in the control compartment, pulled all the way forward and completely to the left or right against the corner posts.

7. If wall-mounted ON/OFF control or thermostat is to be used, mount it in a convenient location on a wall near the fireplace.
8. If an optional control is to be used, wire it in the low voltage circuit as shown in **Figures 48 and 49**.

Note: The supplied 15 feet of 2 conductor wire has one end of each conductor connected to the gas valve circuit and the other end of each conductor placed loose inside the bottom compartment.

9. If the optional control switch is installed, turn the appliance-mounted ON/OFF burner control switch to the OFF position.
10. After the wiring is complete, replace the cover plate.

Note: The gas valve-mounted ON/OFF switch is shown in **Figures 48 and 49**. It is integral with the gas valve and should be set to the **ON** position.

⚠ WARNING

Electronic models of these appliances are equipped with a three-prong (grounding) plug utilized in connecting the electronic components to the junction box in the lower compartment. This grounding plug provides protection against shock hazard and should be plugged directly into the properly grounded three-prong receptacle. DO NOT cut or remove the grounding prong from the plug.

Step 6. WIRING - OPTIONAL FORCED AIR BLOWER KIT

FBK-100 and FBK-200 Kits

(See **Figure 48** on page 25) -

An electrical outlet box is provided for the installation of the **FBK-100, FBK-200** forced air blower kits. Electrical power must be provided to this box to operate these blowers. Install the blower kits according to the installation instructions provided with the kits.

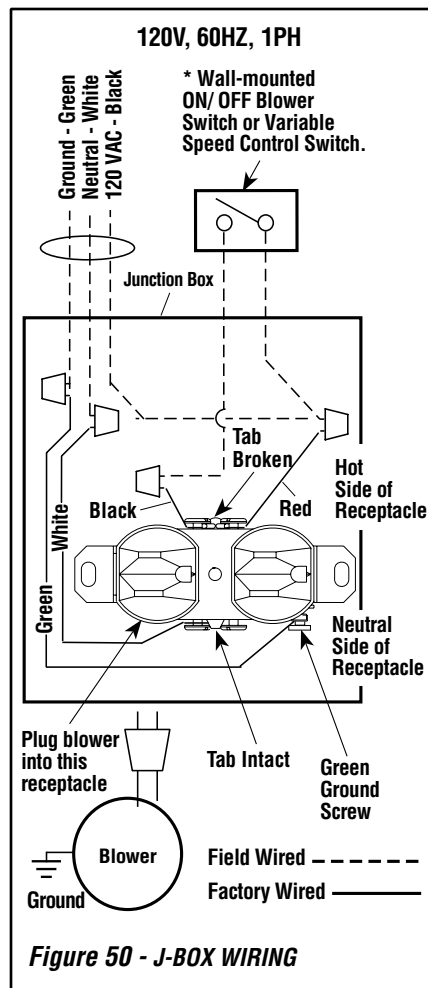

Figure 50 - J-BOX WIRING

FBK-250 Blower Kit

(See **Figure 49** on page 25) -

An electrical outlet box is provided for the installation of the **FBK-250** forced air blower kit. Electrical power must be provided to this box to operate these blowers. Install the blower kit according to the installation instructions provided with the kit.

Note: The tab connecting the receptacles of the outlet box must be broken in **FBK-100** and **FBK-200** blower kit applications. See **Figure 50**.

Step 7. CONNECTING GAS LINE

Make gas line connections. All codes require a shut-off valve mounted in the supply line. **Figure 51** illustrates two methods for connecting the gas supply. The flex-line method is acceptable in the U.S., however, Canadian requirements vary depending on locality. Installation must be in compliance with local codes.

A sediment trap is recommended in the gas piping within the home to prevent moisture and debris in the line from damaging the valve.

These appliances are equipped with a gas flex line for use (where permitted) in connecting the unit to the gas line. A gas flex line is provided to aid in attaching the direct vent appliance to the gas supply. The gas flex line can only be used where local codes permit. Refer to **Figure 51** for flex line description. The flex line is rated for both natural and propane gas. A manual shut off valve is also provided with the flex line.

The gas control valve is located in the lower control compartment.

To access the valve open the lower control compartment door (see **Figure 52**) by pushing in the right top corner of the door. (The door is hinged at the bottom.) Remove the bottom compartment door by sliding the hinge pin, located at the door's left side, to the right until it disengages from the left corner post hole. Pull the door diagonally to the left, away from the fireplace.

The millivolt control valve has a 3/8" (10 mm) NPT thread inlet port. The electronic control valve has a 1/2" (13 mm) NPT thread inlet port and is fitted with a 1/2" x 3/8" (13 mm x 10 mm) NPT fitting.

Secure all joints tightly using appropriate tools and sealing compounds (ensure propane resistant compounds are used in propane applications).

All codes require a shut-off valve mounted in the supply line. The orientation of the shut-off valve should face the front. **Figure 51** illustrates two methods for connecting the gas supply. A sediment Trap is recommended to prevent moisture and debris in the gas line for damaging the valve.

TEST ALL CONNECTIONS FOR GAS LEAKS (FACTORY AND FIELD):

⚠ WARNING

Never use an open flame to check for leaks.

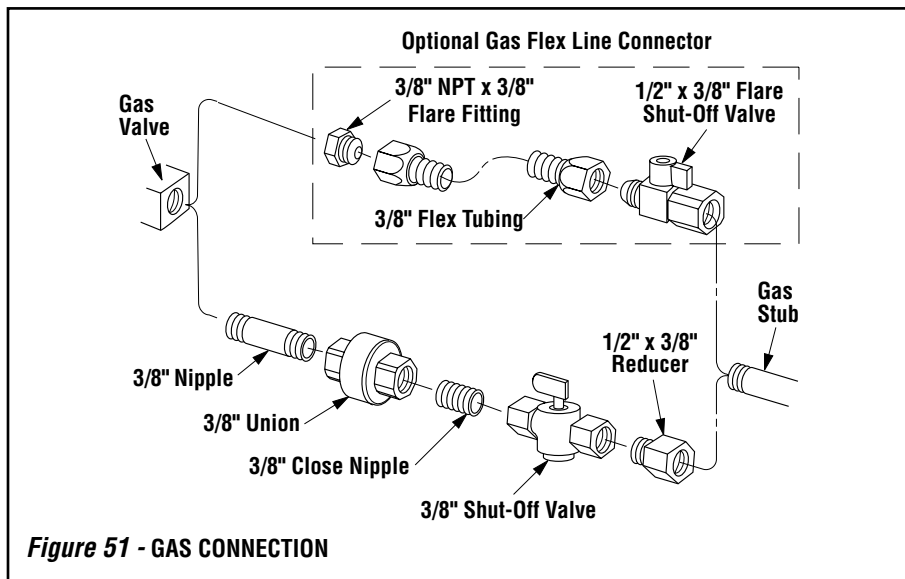

Figure 51 - GAS CONNECTION

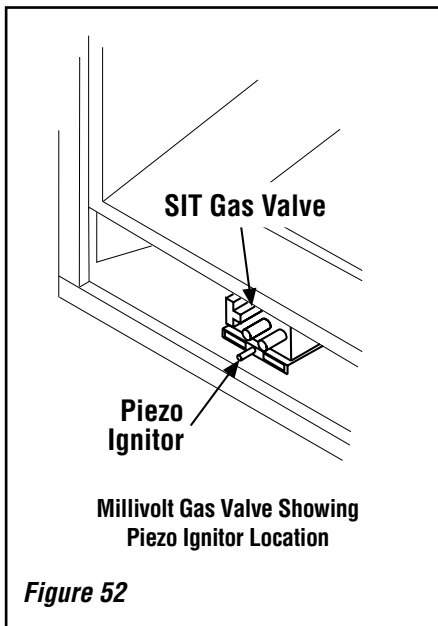

Figure 52

Turn on gas supply and test for gas leaks, using a gas leak test solution (also referred to as bubble leak solution).

Note: Using a soapy water solution is an effective leak test solution but it is not recommended, because the soap residue that is left on the pipes/fittings can result in corrosion over time.

A. Light the appliance (refer to the lighting instructions label in the control compartment or in the Care and Operation Instructions manual).

B. Brush all joints and connections with the gas leak test solution to check for leaks. If bubbles are formed, or gas odor is detected, turn the gas control knob (off/pilot/on) to the "OFF" position. Either tighten or refasten the leaking connection, then retest as described above.

C. When the gas lines are tested and leak free, be sure to rinse off the leak testing solution.

Step 8. VERIFYING APPLIANCE OPERATION

With gas line installed run initial system checkout before closing up the front of the unit. Follow the pilot lighting instructions provided in the Care and Operation Instructions manual. For piezo igniter location see **Figure 47** on **Page 25** (millivolt appliances only).

Note: Lighting Instructions are also found on the literature tag tied to the gas piping next to the gas valve. To access the tag, open the lower control compartment door (**Figure 52**) by pushing in simultaneously the left and right top corners of the door. (The door is hinged at the bottom). Remove the bottom compartment door by sliding the hinge pin, located at the door's left side, to the right until it disengages from the left corner post hole.

When first lighting the appliance, it will take a few minutes for the line to purge itself of air. Once purging is complete, the pilot and burner will light and operate as indicated in the instruction manual.

Subsequent lighting of the appliance will not require such purging. Inspect the pilot flame (remove logs, if necessary, handling carefully).

Millivolt Appliance Checkout

The pilot flame should be steady, not lifting or floating. Flame should be blue in color with traces of orange at the outer edge.

The top 3/8" (10 mm) at the pilot generator (thermopile) and the top 1/8" minimum (tip) of the quick drop out thermocouple should be engulfed in the pilot flame.

The flame should project 1" (25 mm) beyond the hood at all three ports (see **Figure 53**). Replace logs if removed for pilot inspection.

To light the burner; turn "ON" the remote wall switch and rotate the gas valve control knob counterclockwise to the "ON" position ("ON" will be at the top side of the valve).

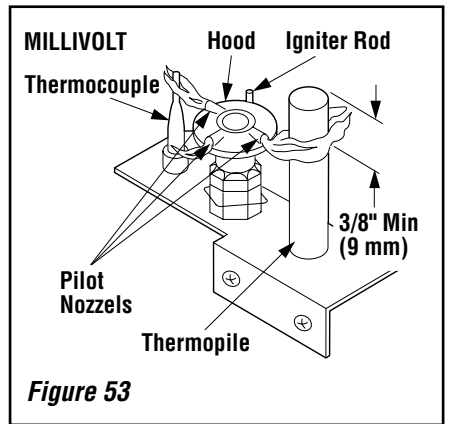

Figure 53

Electronic Appliance Checkout

To light the burner, turn 'ON' the unit mounted On/Off switch or the optional remote wall switch. Ensure the igniter lights the pilot. The pilot flame should engulf the flame rod as shown in **Figure 54**.

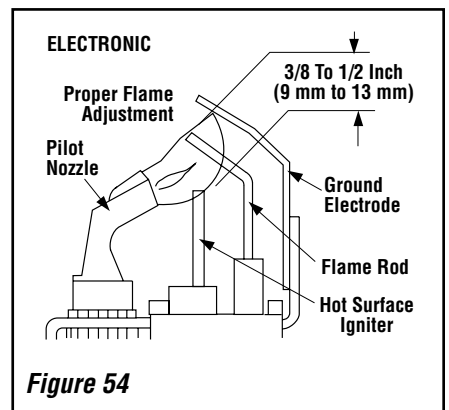

Figure 54

Step 9. INSTALL VOLCANIC STONE, GLOWING EMBERS AND LOGS

NOTE: Turn off all electricity to the appliance before you install volcanic stone, embers and logs. DO NOT attempt to install the logs until the appliance installation has been completed, the gas line connected and tested for leaks and the initial burner operation has been checked out.

Step 1. Remove the appliance front door (see Removing Glass Enclosure panel on page 32).

Step 2. Install decorative volcanic stone - Sprinkle the decorative volcanic stone in a pleasing pattern. The volcanic stone should be placed directly on top of the firebox bottom, along the front and to the back at the right and left sides of the burner. Position any optional ceramic fiber liners before placing the stone. Logs should be positioned after the volcanic stone.

Note: This appliance is provided with enough Glowing Embers for several applications, do not feel compelled to use all that is in a new bag. For best glowing effect, replace the ember material annually. Replacement Glowing Embers are available (Catalog Number 88L53).

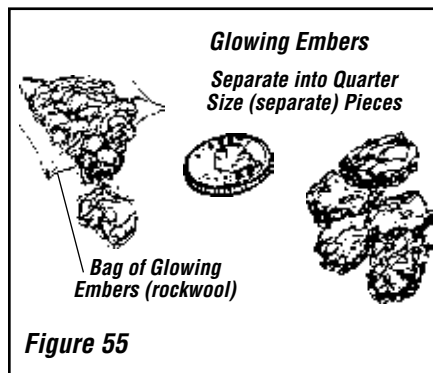

Figure 55

Step 3. Separate the Glowing Ember (Rockwool) into pieces about the size of a quarter (**Figure 55**). Keep the pieces fluffed up, not matted. Distribute these pieces over the front surface of the burner, as shown in **Figure 56**. Do not use more than is necessary. When properly positioned, the Glowing Embers will cover approximately 65% of the front burner and with no appreciable gaps or openings. Ensure that the main burner ports remain uncovered by the ember material.

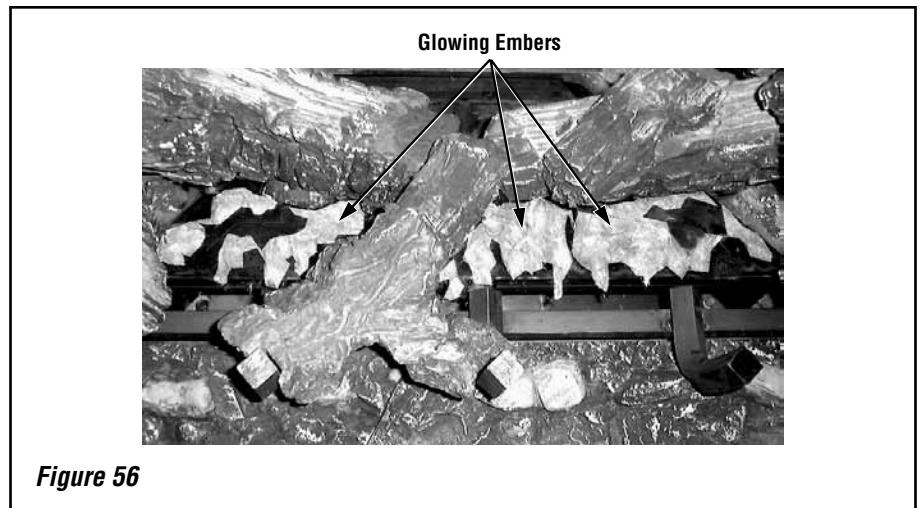

Figure 56

Step 4. Placement of Logs -

All top logs that rest on lower logs, do so over notches, indents or nubs. Proper log placement is critical to prevent sooting. Logs should be placed in the gaps between the flame peaks and should be positioned so they do not impinge the flames.

Step 5. Position the individual logs as shown in **Figures 57, 58 and 59**. Logs should be placed in the order shown. All logs that have notches to fit over the grate tines should be positioned with these notches directly against the grate. **Handle logs carefully to prevent breakage.**

Proper log placement is critical to encourage outstanding flame appearance and prevent sooting. When positioned properly as shown, logs will be positioned between flame peaks and will not impinge any flames.

Refer to **Figure 57** for MPD-3328 Series appliances, to **Figure 58** for MPD-3530 Series appliances and to **Figure 59** for MPD-4035 and MPD-4540 Series appliances.

REFERENCE Firebox Accessories / Parts		
Cat. No.	Model No.	Description
88L53	FGE	Bag of Glowing Embers
80L42	FDVS	Bag of Decorative Volcanic Stone

! WARNING

- DO NOT attempt to install the logs until the appliance installation has been completed, the gas line connected and tested for leaks and the initial burner operation has been checked out.
- The size and position of the log set was engineered to give the appliance a safe, reliable and attractive flame pattern. Any attempt to use a different log set in the fireplace will void the warranty and will result in incomplete combustion, sooting, and poor flame quality.
- Logs get very hot and will remain hot up to one hour after gas supply is turned off. Handle only when logs are cool. Turn off all electricity to the appliance before you install grate, volcanic stone, vermiculite, embers and logs.
- This appliance is not designed to burn wood. Any attempt to do so could cause irreparable damage to the appliance and prove hazardous to your safety.
- If logs are not installed according to the log installation instructions, flame impingement and improper combustion could occur and result in soot and/or excessive production of carbon monoxide (CO), a colorless, odorless, toxic gas.

MPD-3328 LOG PLACEMENT

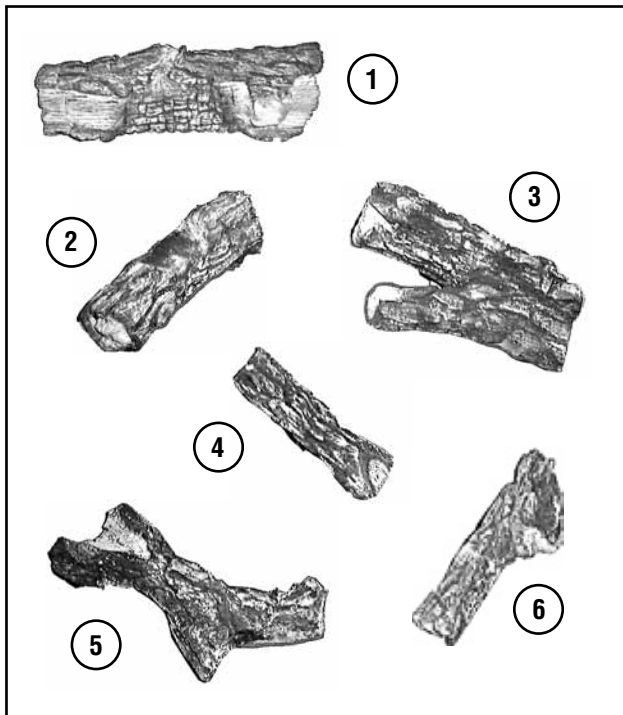

Log Number	Description (Stamped #)
1	Log, Rear (39-12)
2	Log, Left (39-1)
3	Log, Right (39-2)
4	Log, Top Center (39-13)
5	Log, Top/Left (39-3)
6	Log, Top/Right (39-4)

Catalog Number for the entire log set: 24M15

Position the individual logs as shown below. Logs should be placed in the order shown. Position the rear log on the brackets at the rear of the firebox with the log's notches directly over the brackets. Position the right log (log no. 3) by inserting the pin from the rear log into the hole on its upper end. Place the left log and then the smaller left and right top logs. All logs that have notches to fit over the grate tines should be positioned with these notches directly against the grate. All top logs that rest on lower logs, do so over flattened mounting faces in the bottom logs.

Proper log and twig placement is critical to encourage outstanding flame appearance and prevent sooting.

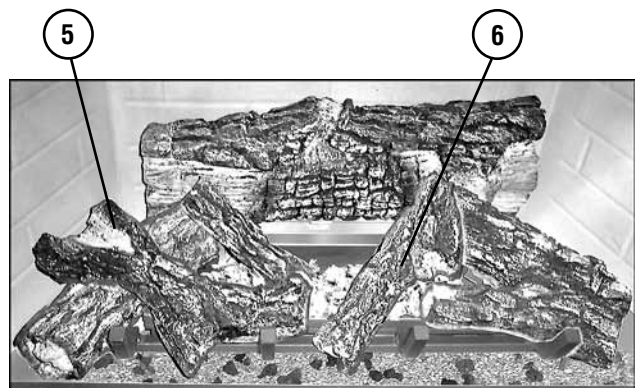
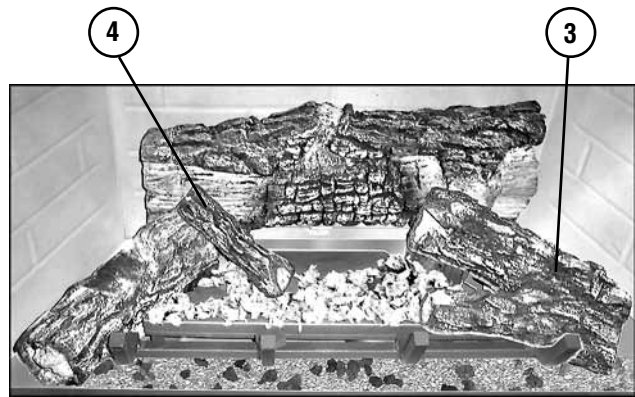
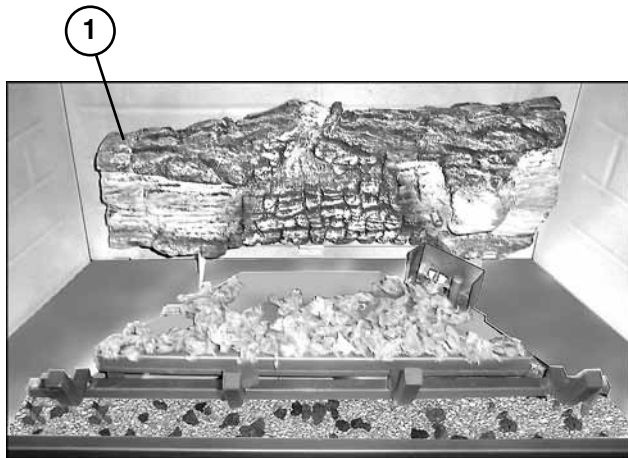
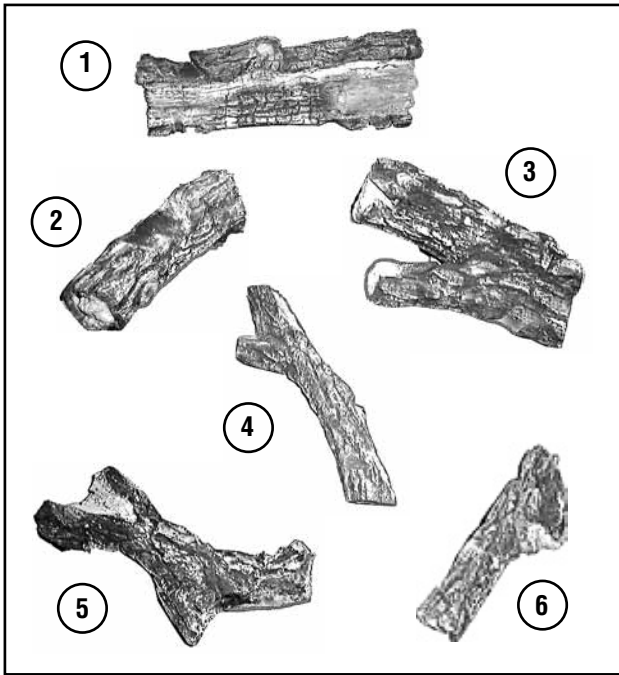

Figure 57

NOTE: DIAGRAMS & ILLUSTRATIONS ARE NOT TO SCALE.

MPD-3530 LOG PLACEMENT



Log Number	Description (Stamped #)
1	Log, Rear (39-5)
2	Log, Left (39-1)
3	Log, Right (39-2)
4	Log, Top Center (39-6)
5	Log, Top/Left (39-3)
6	Log, Top/Right (39-4)

Catalog Number for the entire log set: 24M22

Position the individual logs as shown below. Logs should be placed in the order shown. Position the rear log on the brackets at the rear of the firebox with the log's notches directly over the brackets. Position the right log (log no. 3) by inserting the pin from the rear log into the hole on its upper end. Place the left log and then the smaller left and right top logs. All logs that have notches to fit over the grate tines should be positioned with these notches directly against the grate. All top logs that rest on lower logs, do so over flattened mounting faces in the bottom logs.

Proper log and twig placement is critical to encourage outstanding flame appearance and prevent sooting.

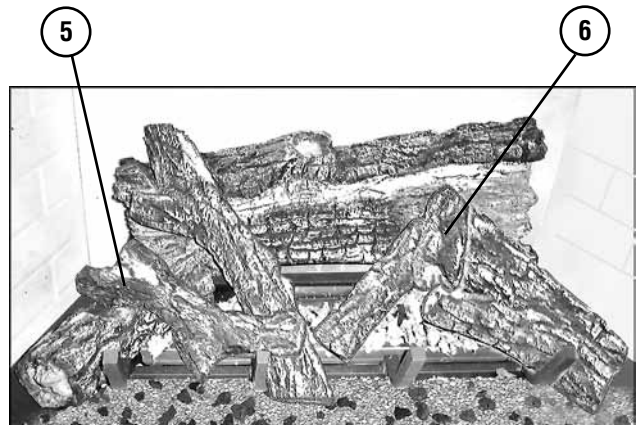
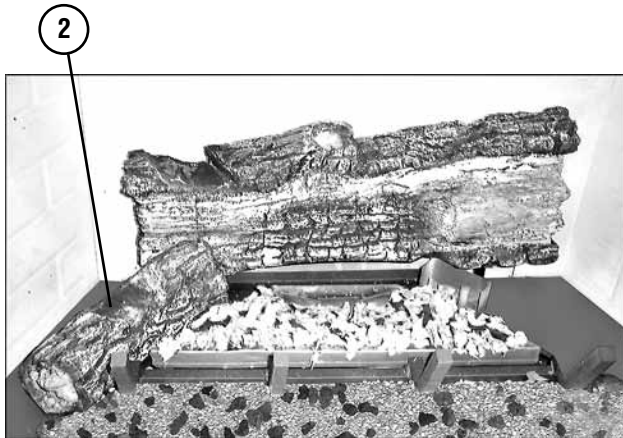
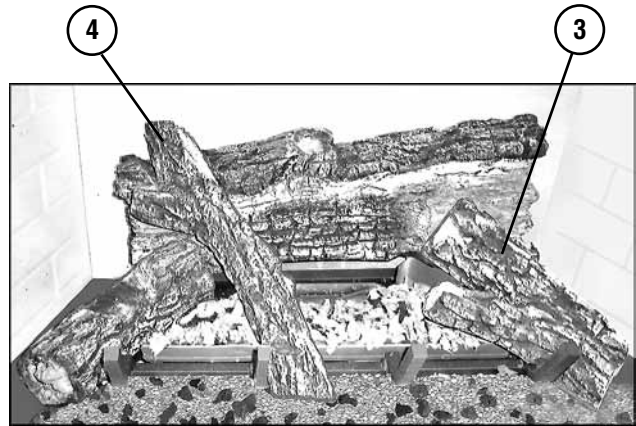
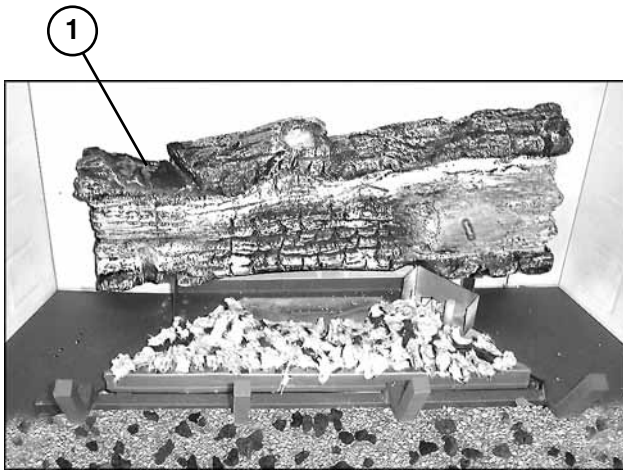
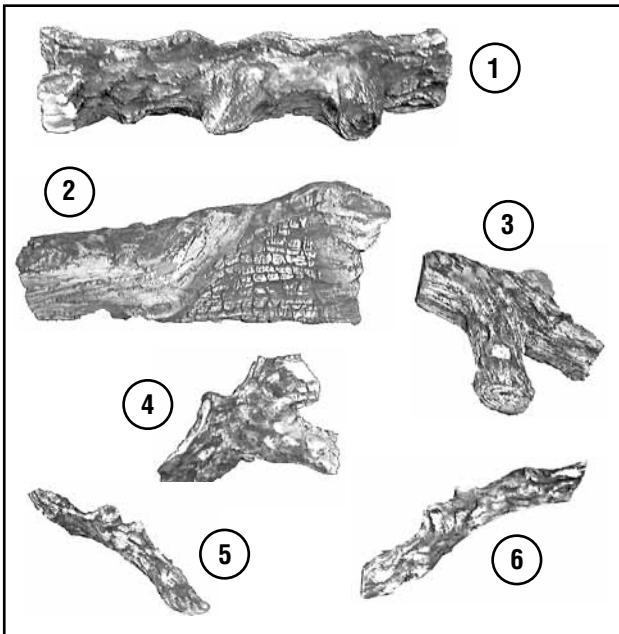

Figure 58

NOTE: DIAGRAMS & ILLUSTRATIONS ARE NOT TO SCALE.

MPD-4035 AND MPD-4540 LOG PLACEMENT



Log Number	Description (Stamped #)
1	Log, Center (39-8)
2	Log, Rear (138)
3	Log, Right (39-10)
4	Log, Left (39-9)
5	Log, Top/Left (39-11)
6	Log, Top/Right (39-11)

Catalog Number for the entire log set: 24M25

Position the individual logs as shown below. Logs should be placed in the order shown. Position the center log on the burner first, then place the glowing embers as shown in **Figure 56**. Place the rear log, both the right and left, and then the smaller left and right top logs. All logs that have notches to fit over the grate tines should be positioned with these notches directly against the grate. All top logs that rest on lower logs, do so over flattened mounting faces in the bottom logs.

Proper log and twig placement is critical to encourage outstanding flame appearance and prevent sooting.

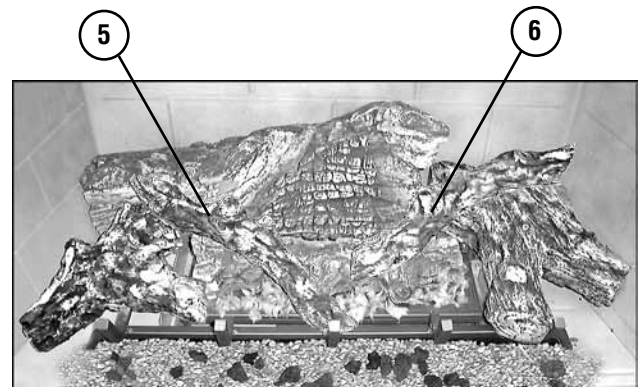
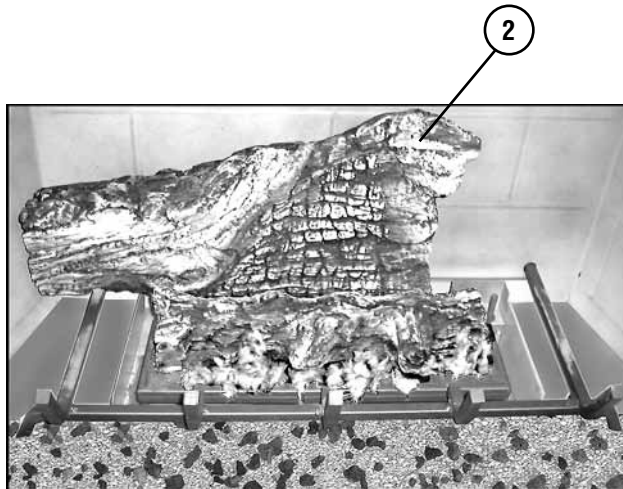
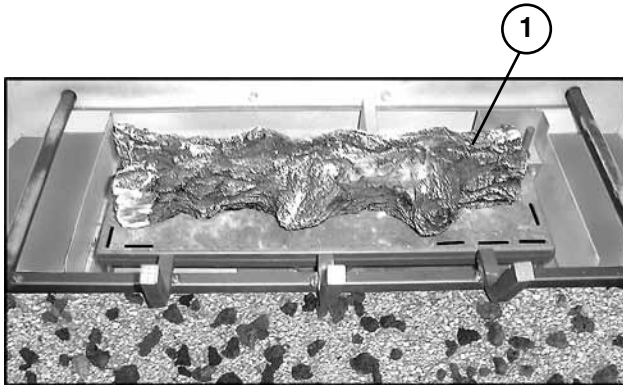

Figure 59

NOTE: DIAGRAMS & ILLUSTRATIONS ARE NOT TO SCALE.

Step 10. REMOVING AND INSTALLING THE GLASS DOOR

⚠ WARNING

- Do not attempt to substitute the materials used on these doors, or replace cracked or broken glass.
- Handle this glass with extreme care! Glass is susceptible to damage – Do not scratch or handle roughly while reinstalling the glass door frame.
- The glass door(s) of this appliance must only be replaced as a complete unit as provided by the manufacturer. Do not attempt to replace broken, cracked or chipped glass separately.
- Do not attempt to touch the front enclosure glass with your hands while the fireplace is in use.

⚠ WARNING

Do not operate appliance with the glass front removed, cracked or broken.

⚠ AVERTISSEMENT

Ne pas utiliser l'appareil si le panneau frontal en verre n'est pas en place, est craqué ou brisé.

Only doors certified with the appliance shall be used.

Seules des portes certifiées pour cet appareil doivent être utilisées.

CAUTION: DO NOT abuse glass door by striking or slamming shut.

Removing Glass Enclosure Panel (see *Figure 60*)

Remove the top louver assembly or radiant panel.

To access the glass door securing latches, first open the lower control compartment door (*Figure 60*) by pushing in simultaneously the left and right top corners of the door (the door is hinged at the bottom).

Remove the bottom compartment door by sliding the hinge pin, located at the door's left side, to the right until it disengages from the left corner post hole. Pull the door diagonally to the left, away from the fireplace.

Locate the two (2) latches at the top of the control compartment and disengage them from the door frame bottom vee-flange, pulling down on their handles to open them.

Installing Glass Enclosure Panel (see *Figure 60*)

Retrieve the glass door. Visually inspect the gasket on the backside of the frame. Gasket surface must be clean, free of irregularities and seated firmly.

Position the door in front of the firebox opening with the bottom of the door held away from the fireplace (*Figure 60*). Hook the top flange of the door frame over the top of the firebox frame.

Let the bottom of the door frame swing gently in towards the fireplace ensuring that the gasket seats evenly as the door frame draws shut. Fasten the two latches located underneath the firebox floor to the door's vee-flange. Close both the latches securely.

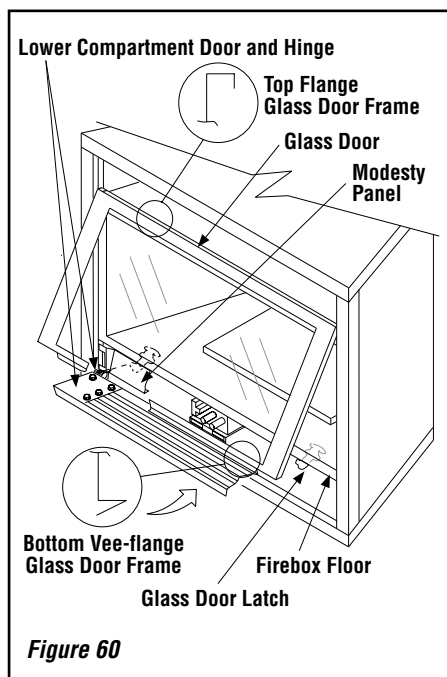

Figure 60

Step 11. BURNER ADJUSTMENTS

Flame Appearance and sooting

Proper flame appearance is a flame which is blue at the base and becomes yellowish-orange in the body of the flame.

When the appliance is first lit, the entire flame may be blue and will gradually turn yellowish-orange during the first 15 minutes of operation. If the flame remains blue, or if the flame is orange with evidence of sooting (black tip), the air shutter opening may need to be adjusted.

If the air shutter opening is closed too far, sooting may develop. Sooting is indicated by black puffs developing at the tips of very long orange flames. Sooting results in black deposits forming on the logs, appliance inside surfaces and on exterior surfaces adjacent to the vent termination.

Sooting is caused by incomplete combustion in the flames and lack of combustion air entering the air shutter opening. To achieve a warm yellowish-orange flame with an orange body that does not soot, the shutter opening must be adjusted between these two extremes.

Air Shutter Adjustment Guidelines

- If there is smoke or soot present, first check the log set positioning to ensure that the flames are not impinging on any of the logs. If the log set is properly positioned and a sooting condition still exists, then the air shutter opening should be increased.
- The more offsets in the vent system, the larger the air shutter opening will need to be.
- An appliance operated with the air shutter opened too far, may have flames that appear blue and transparent. These weak, blue and transparent flames are termed anemic.
- Propane models may exhibit flames which candle or appear stringy. If this is present and persists, adjust the air shutter to a more closed position, then operate the appliance for a few more minutes to ensure that the flame normalizes and the flames do not appear sooty.

The following chart is provided to aid you in achieving the correct air shutter adjustment for your installation.

Air Shutter Adjustment Guidelines:		
Amount of Primary Air	Flame Color	Air Shutter Adjustment
If air shutter is closed too far →	Flame will be orange →	Air shutter gap should be increased
If air shutter is open too far →	Flame will be blue →	Air shutter gap should be decreased

NOTE: DIAGRAMS & ILLUSTRATIONS ARE NOT TO SCALE.

⚠ WARNINGS

- Air shutter adjustment should only be performed by a qualified professional service technician.
- Ensure front glass panel are in place and sealed during adjustment.

⚠ CAUTIONS

- Soot will be produced if the air shutter is closed too much. Any damage due to sooting, resulting from improperly setting the air shutter, is not covered under the warranty.
- The air shutter door and nearby appliance surfaces are hot. Exercise caution to avoid injury while adjusting flame appearance.

1. Refer to **Figures 61, 62 and 63** for proper flame appearance. To adjust the flame, rotate the adjustment rod toward the back or toward the front of the fireplace (rod located in the lower control area). Position the air shutter to the factory setting as shown in the table in **Figure 64**.
2. Light appliance (follow lighting procedure on lighting label in control compartment or see the Care and Operation Manual).
3. Allow the burner to operate for at least 15 minutes while observing the flame continuously to ensure that the proper flame appearance has been achieved. If the following conditions are present, adjust accordingly.
 - If flame appears weak or sooty, adjust the air shutter, incrementally, to a more open position until the proper flame appearance is achieved.
 - If flame remains blue, adjust the air shutter, incrementally, to a more closed position until the proper flame appearance is achieved.
4. Leave the control knob (off/pilot/on) in the ON position and the burner OFF/ON switch OFF (and remote switches, if applicable).
5. When satisfied that the burner flame appearance is normal, re-install the lower control compartment door then proceed to finish the installation.

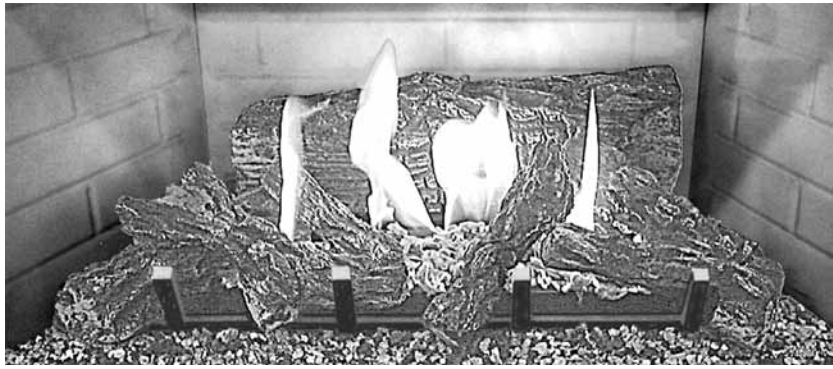

Figure 61

MPD-3328 MODEL

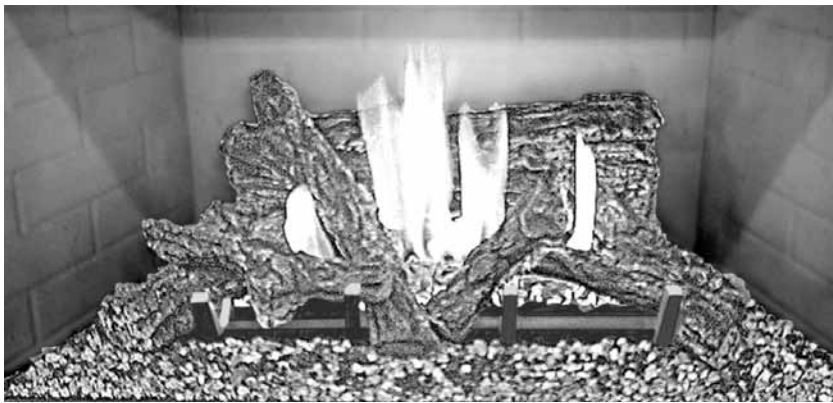

Figure 62

MPD-3530 MODEL

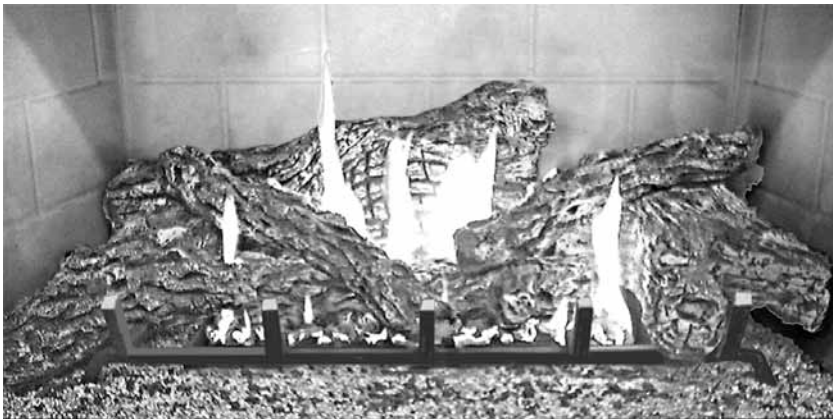
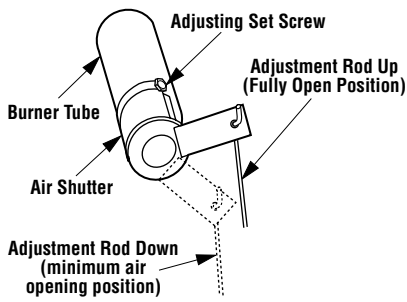

Figure 63

MPD-4035 AND MPD-4540 MODEL



Models	Gas Type	FACTORY AIR SHUTTER SETTING inches (mm)
MPDT-3328	Nat.	1/32 (0.8)
	Prop.	3/16 (4.76)
MPDR-3328	Nat.	1/32 (0.8)
	Prop.	3/16 (4.76)
MPD-3530	Nat.	1/32 (0.8)
	Prop.	3/16 (4.76)
MPD-4035	Nat.	1/8 (3.2)
	Prop.	1/2 (13)
MPD-4540	Nat.	1/8 (3.2)
	Prop.	1/2 (13)

Figure 64

Step 12. HOOD INSTALLATION

Refer to Figures 65 and 66. All of these appliances must have hoods installed prior to operating.

On all clean face units, slide the hood into the slots on the lower edge of the radiant panel (Figure 65).

On louvered face units, slide the hood into the slots on the lower edge of the cabinet top (Figure 66).

FINISHING REQUIREMENTS - Wall Details

Complete finished interior wall. To install the appliance facing flush with the finished wall, position framework to accommodate the thickness of the finished wall (Figures 65 and 66)

See Page 5 for Cold Climate Insulation and Page 8 for Clearances.

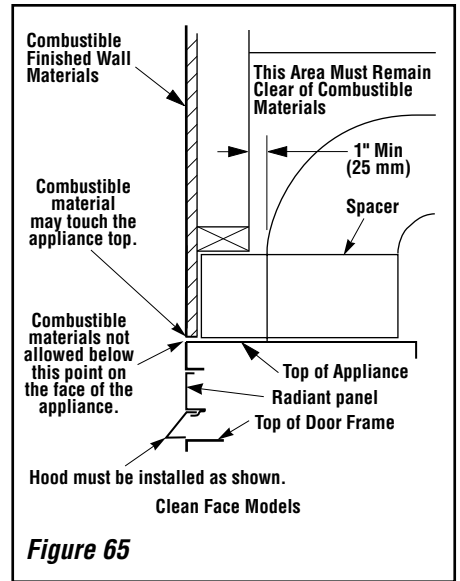

Figure 65

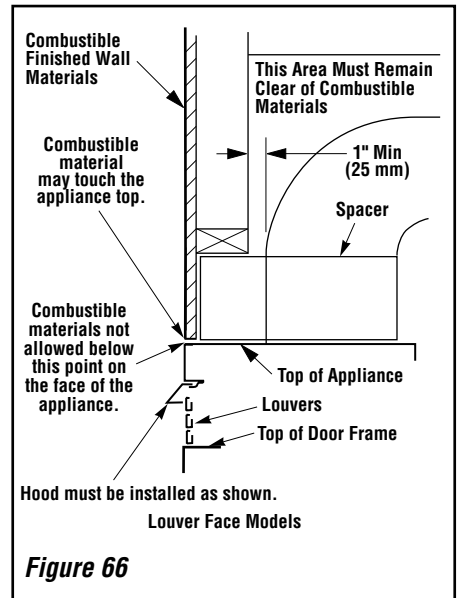

Figure 66

STEP 13. ATTACHING SAFETY-IN-OPERATION WARNINGS

It is the installer's responsibility to ensure these warnings are properly affixed during installation. These warning labels are a critical step in informing consumers of safe operation of this appliance.

ATTACHING SAFETY-IN-OPERATION WARNINGS

It is required that the safety instruction labels furnished with the fireplace be affixed to the operation and control point of the fireplace. A safety instruction label must be affixed to the wall switch plate where the fireplace is turned on and off (See **Figure A**) or wall thermostat (See **Figure B**) and if used on the remote control handheld transmitter (**Figure C**). To properly complete the installation of this fireplace, locate the multi-lingual adhesive labels provided with the Care and Operation Instructions and proceed as follows:

1. Locate the wall switch or wall thermostat that controls the fireplace (verify the switch operates the fireplace by turning it on and off). Clean the wall switch plate or wall thermostat thoroughly to remove any dust and oils. Affix the label to the surface of the plate of the wall switch that controls the fireplace (**Figure A**) or the wall thermostat (**Figure B**). Choose the language primarily spoken in the home. If unknown, affix the English language label.
2. If a remote control is used to control the fireplace, locate the transmitter and clean it thoroughly to remove any dust and oils. Affix the label to the surface of handheld transmitter (**Figure C**). Choose the language primarily spoken in the home. If unknown, affix the English language label.
3. If you are unable to locate the labels, please call Lennox Hearth Products or your nearest Lennox Hearth Products dealer to receive additional safety instruction labels free of charge.

Cat. No. H8024 Replacement Label Kit

LENNOX HEARTH PRODUCTS
1-800-9-LENNOX

Note: English is red text on clear label. French and Spanish are white text on black label.

SAFETY LABEL DIAGRAMS



Figure A

APPOSITION DES MISES EN GARDE RELATIVES À LA SÉCURITÉ D'UTILISATION

Il est impératif que les étiquettes de sécurité fournies avec le foyer soient collées à côté des dispositifs de contrôle du foyer. Une étiquette de sécurité doit être collée sur la plaque de l'interrupteur contrôlant l'allumage du foyer (voir **Figure A**) ou sur le thermostat mural (voir **Figure B**) et, le cas échéant, sur le boîtier de la télécommande (**Figure C**). Pour achever l'installation correcte de ce foyer, procédez comme suit avec les étiquettes adhésives en langues étrangères fournies avec les instructions d'utilisation et d'entretien :

1. Repérez l'interrupteur ou le thermostat mural qui contrôle le foyer (vérifiez que l'interrupteur contrôle le fonctionnement du foyer en le faisant basculer de Marche à Arrêt, et vice-versa). Nettoyez soigneusement la plaque murale de l'interrupteur ou le thermostat mural pour éliminer la poussière et les traces de graisse ou d'huile. Collez l'étiquette sur la surface de la plaque de l'interrupteur mural qui contrôle le foyer (**Figure A**) ou du thermostat mural (**Figure B**). Choisissez la langue qui est principalement parlée dans la résidence du propriétaire. En cas de doute, collez l'étiquette en anglais.
2. Si une télécommande est utilisée pour contrôler le foyer, nettoyez la soigneusement pour éliminer la poussière et les traces de graisse ou d'huile. Collez l'étiquette sur le boîtier de la télécommande (**Figure C**). Choisissez la langue qui est principalement parlée dans la résidence du propriétaire. En cas de doute, collez l'étiquette en anglais.
3. Si vous ne trouvez pas les étiquettes, veuillez appeler Lennox Hearth Products ou votre distributeur Lennox Hearth Products local pour recevoir gratuitement des étiquettes supplémentaires.

Étiquettes de remplacement, n° cat. H8024

LENNOX HEARTH PRODUCTS
1-800-9-LENNOX

Remarque : Le texte anglais est rouge sur un support transparent. Le texte français et espagnol est blanc sur un support noir.

DIAGRAMMES DES ÉTIQUETTES DE SÉCURITÉ



Figure B

COLOCACIÓN DE ADVERTENCIAS DE SEGURIDAD EN OPERACIÓN

Se requiere que las etiquetas de instrucciones de seguridad incluidas con la chimenea se coloquen en el punto de operación y control de la misma. Se debe colocar una etiqueta de instrucciones de seguridad en la placa del interruptor de pared desde el cual se enciende y se apaga la chimenea (ver la **Figura A**) o en el termostato de pared (ver la **Figura B**) y en el transmisor de control remoto (**Figura C**) si se usa. Para completar correctamente la instalación de esta chimenea, encuentre las etiquetas adhesivas multilingües incluidas con las instrucciones de cuidado y operación y haga lo siguiente:

1. Identifique el interruptor o el termostato de pared que controla la chimenea (verifique que el interruptor opera la chimenea encendiéndola y apagándola). Limpie bien la placa del interruptor o el termostato de pared para quitar el polvo y aceite. Pegue la etiqueta en la superficie de la placa del interruptor que controla la chimenea (**Figura A**) o en el termostato de pared (**Figura B**). Seleccione el idioma que más se habla en la casa. Si no sabe cuál es, use la etiqueta en inglés.
2. Si se usa un control remoto para controlar la chimenea, encuentre el transmisor y límpielo bien para quitar el polvo y aceite. Pegue la etiqueta en la superficie del transmisor (**Figura C**). Seleccione el idioma que más se habla en la casa. Si no sabe cuál es, use la etiqueta en inglés.
3. Si no puede encontrar las etiquetas, sírvase llamar a Lennox Hearth Products o al distribuidor de Lennox Hearth Products más cercano para recibir etiquetas de instrucciones de seguridad adicionales gratuitas.

Juego de etiquetas de repuesto - N° de cat. H8024

LENNOX HEARTH PRODUCTS
1-800-9-LENNOX

Nota: La etiqueta en inglés es transparente con texto rojo. Las etiquetas en francés y español son negras con texto blanco.

DIAGRAMAS DE ETIQUETAS DE SEGURIDAD



Figure C

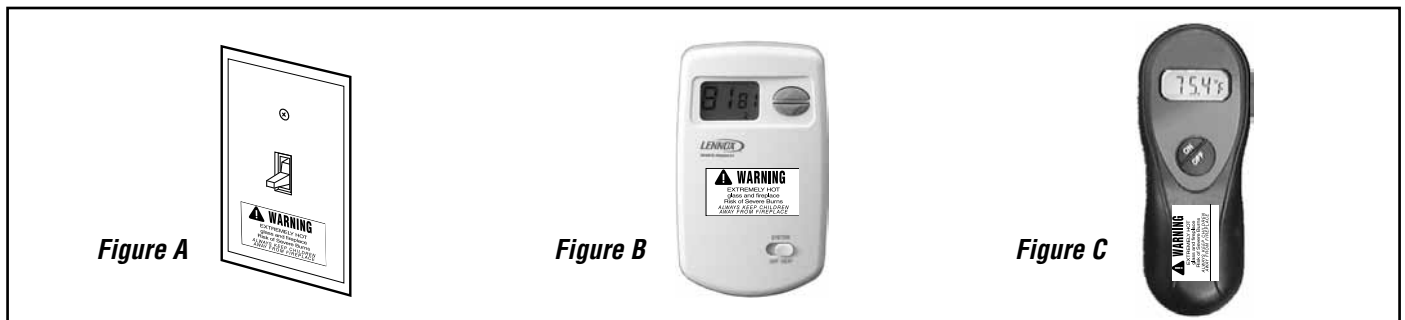

NOTE: DIAGRAMS & ILLUSTRATIONS ARE NOT TO SCALE.



INSTALLATION ACCESSORIES

Listed Secure Vent™ Components			
	Cat. No.	Model	Description
	H1968	SV4.5HT-2	Horizontal Square Termination With Firestop / spacer (H2246) & Adaptor (74L61)
	H2152	SV4.5CGV-1	Vertical Termination Cap, High Wind
	H4687	SV4.5CTS	Chase Top Termination, Square, Ref. instr. #750,207M
	H4716	SV4.5CTS-B	Chase Top Termination, Square, Black, Ref. instr. #750,207M
	H4717	SV4.5CTS-TC	Chase Top Termination, Square, Terra Cotta, Ref. instr. #750,207M
	94L10*	SV4.5HTSS	Horizontal Small Square Termination with Firestop/Spacer (96K80) and Adapter (74L61)
	98L27*	SV4.5HTSSL	Horizontal Small Square-Long Termination with Firestop/Spacer (96K80) and Adapter (74L61)
	17M52	SV4.5HGS-1	Termination Guard, Square (1 pack) Ref. instr. #750,109M
	17M53	SV4.5HGS-12	Termination Guard, Horizontal Square (12 pack) Ref. instr. #750,109M
	87L02	SV4.5HGS	Termination Guard for Horizontal Square Termination (Deluxe) (1 pack) Ref. instr. #750,055M
	H5820	SV4.5HTSK	Termination Shroud (Guard) for Horizontal Square Termination (1 pack) (ref. instr. #750246M)
	H3907	SV4.5ARSA	Attic Insulation Shield w/ adjustable height, 12"-22"
	H1988	CTSA-33	Chase Top Shroud Kit, Arch Top 3 X 3 Ft., Ref. instr. #750,194M
	H1985	CTSO-33	Chase Top Shroud Kit, Open Top 3 X 3 Ft., Ref. instr. #750,193M
	H1987	CTSO-44	Chase Top Shroud Kit, Open Top 4 X 4 Ft., Ref. instr. #750,193M
	H1986	CTSO-46	Chase Top Shroud Kit, Open Top 4 X 6 Ft., Ref. instr. #750,193M

Listed Secure Vent™ Components			
	Cat. No.	Model	Description
	77L70	SV4.5L6	6 Inch (152 mm)
	77L71	SV4.5L12	12 Inch (305 mm)
	77L72	SV4.5L24	24 Inch (610 mm)
	77L73	SV4.5L36	36 Inch (914 mm)
	77L74	SV4.5L48	48 Inch (1219 mm)
	77L75	SV4.5LA	Telescopic Length Slip Section (2' to 7-1/2' rigid)
	77L76	SV4.5E45	45 Degree Elbow
	77L77	SV4.5E90	90 Degree Elbow
	10K81	SFMP	Mill-Pac, Black, High Temperature Sealant
	89L40	SFMP-12	Mill-Pac, Black, High Temperature Sealant - Bulk 12 pack
	99L02	SV4.5HRK14	Horizontal Riser Kit, 14", Ref. instr. #750,146M
	99L03	SV4.5HRK36	Horizontal Riser Kit, 36", Ref. instr. #750,146M
	96K93	SV4.5SU	Support Strap
	H5816	SV4.5-TWSK10	Through Wall Shield Kit (used to shield the direct-vent pipe from blown insulation) Ref. instr. #750,247M
The following flashings come packaged with a storm collar:			
	77L78	SV4.5F	Flat Roof Flashing
	77L79	SV4.5FA	1/12 to 7/12 Adjustable Flashing
	77L80	SV4.5FB	7/12 to 12/12 Adjustable Flashing
	77L81	SV4.5SC6	Storm Collar (6 per box)
	H6183	SV4.5HF5	Firestop Spacer, 5", rigid
	H6184	SF4.5HF5	Firestop Spacer, 5", flex
	H2246	SV4.5HF-10	Firestop / Spacer-Horizontal, rigid (3-1-1 spacing), 10 Pack
	H2247	SV4.5VF-10	Firestop / Spacer-Vertical, rigid (1-1-1 spacing), 10 Pack
	96K92	SV4.5SP	Support Plate

* Only for use with MPDT/R-3328 and MPD-3530 models.

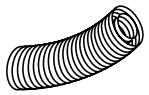
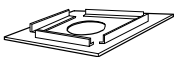
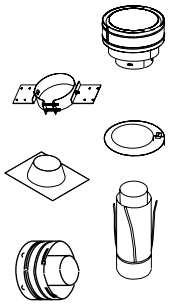
INSTALLATION ACCESSORIES CONTINUED

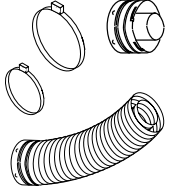
Listed Secure Flex™ Components			
	Cat. #	Model	Description
These termination kits include firestop/spacer, gear clamps and flex adaptor.			
	60L10	SF-18	18 feet (5.49 m) * compressed flex , Ref. instr. #750,053M
	98K03	SF-12	12 feet (3.66 m) * compressed flex , Ref. instr. #750,052M
	H2248	SF4.5HF-10	Firestop / Spacer - Horizontal, flex (3-1-1 spacing), 10 Pack
	H2249	SF4.5VF-10	Firestop/Spacer-Vertical, flex (1-1-1 spacing), 10 Pk
	56L74	SFVT30	Vertical Termination for flex (flat to 6/12) with flex adaptor, section of rigid vent, roof support collar assembly, roof flashing and storm collar. Ref. instr. #750,052M
	56L75	SFVT45	Vertical Termination for flex (6/12 to 12/12) with flex adaptor, section of rigid vent, roof support collar assembly, roof flashing and storm collar. Ref. instr. #750,052M
	91L66	SFGC4-6	Gear Clamp 4.5 in. (114 mm) for flex (6 pack)
	91L67	SFGC7-6	Gear Clamp 7.5 in. (190.5 mm) for flex (6 pack)
	H7748	H7748	36" Flex Connector Kit. 36" of flex with two adapters for mating two rigid sections of vent together.

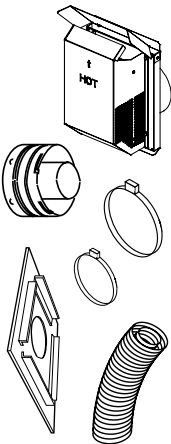
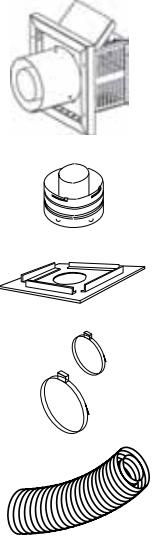
Listed Secure Flex™ Components			
	Cat. #	Model	Description
	H1969	SF4.5HT-2	Horizontal Square Termination for flex (without flex)
	77L87	SFKIT12S	Square Term. for flex (with 12 inch [305 mm] ** compressed flex)
	77L88	SFKIT18S	Square Term. for flex (with 18 inch [457 mm] ** compressed flex)
	77L89	SFKIT24S	Square Term. for flex (with 24 inch [610 mm] ** compressed flex)
	77L90	SFKIT36S	Square Term. for flex (with 36 inch [914 mm] ** compressed flex)
	77L91	SFKIT48S	Square Term. for flex (with 48 inch [1219 mm] ** compressed flex)
	94L04*	SFKIT12SS	Small Square Termination for flex , with 12 in. (305 mm) of ** compressed flex vent (ref. Form #750,204M)
	94L05*	SFKIT18SS	Small Square Termination for flex , with 18 in. (457 mm) of ** compressed flex vent (ref. Form #750,204M)
	94L06*	SFKIT24SS	Small Square Termination for flex , with 24 in. (610 mm) of ** compressed flex vent (ref. Form #750,204M)
	94L07*	SFKIT36SS	Small Square Termination for flex , with 36 in. (914 mm) of ** compressed flex vent (ref. Form #750,204M)
	94L08*	SFKIT48SS	Small Square Termination for flex , with 48 in. (1219 mm) of ** compressed flex vent (ref. Form #750,204M)
	94L09*	SF-HTSS	Horizontal Small Square Termination for flex , without flex vent (ref. Form #750,204M)

* Only for use with MPDT/R-3328 and MPD-3530 models.

** All compressed flex vents can be expanded up to two times.

GAS CONVERSION KITS

WARNING

This conversion kit shall be installed by a qualified service agency in accordance with the manufacturer's instructions and all applicable codes and requirements of the authority having jurisdiction. If the information in these instructions is not followed exactly, a fire, explosion or production of carbon monoxide may result causing property damage, personal injury or loss of life. The qualified service agency is responsible for the proper installation of this kit. The installation is not proper and complete until the operation of the converted appliance is checked as specified in the manufacturer's instructions supplied with the kit. The qualified service agency performing this installation assumes responsibility for this conversion.

AVERTISSEMENT

Cette trousse de conversion doit être installée par un technicien agréé, selon les instructions du fabricant et selon toutes les exigences et tous les codes pertinents de l'autorité compétente. Assurez-vous de bien suivre les instructions dans cette notice pour réduire au minimum le risque d'incendie, d'explosion ou la production de monoxyde de carbone pouvant causer des dommages matériels, des blessures ou la mort. Le technicien agréé est responsable de l'installation de cette trousse. L'installation n'est pas adéquate ni complète tant que le bon fonctionnement de l'appareil converti n'a pas été vérifié selon les instructions du fabricant fournies avec la trousse. Le fournisseur de service qualifié ayant réalisé l'installation assume les responsabilités liées à la conversion.

In Canada:

THE CONVERSION SHALL BE CARRIED OUT IN ACCORDANCE WITH THE REQUIREMENTS OF THE PROVINCIAL AUTHORITIES HAVING JURISDICTION AND IN ACCORDANCE WITH THE REQUIREMENTS OF THE CAN/CSA-B149.1 INSTALLATION CODE.

LA CONVERSION DEVRA ÊTRE EFFECTUÉE CONFORMÉMENT AUX RECOMMANDATIONS DES AUTORITÉS PROVINCIALES AYANT JURISDICTION ET CONFORMÉMENT AUX EXIGENCES DU CODE D'INSTALLATION CAN/CSA-B149.1.

Gas conversion kits are available to adapt your appliance from the use of one type of gas to the use of another. These kits contain all the necessary components needed to complete the task including labeling that must be affixed to ensure safe operation.

Kit part numbers are listed here and the following steps detail the conversion procedure. Refer to the instructions provided with the conversion kit when performing any gas conversion.

<i>Millivolt SIT Systems Natural Gas To Propane Gas Conversion Kits</i>	
Models	Catalog No.
MPDT/R-3328	H2009
MPD-3530	H2011
MPD-4035	H2013
MPD-4540	H2015

<i>Millivolt SIT Systems Propane Gas to Natural Gas Conversion Kits</i>	
Models	Catalog No.
MPDT/R-3328	H2010
MPD-3530	H2012
MPD-4035	H2014
MPD-4540	H2016

Electronic HONEYWELL Systems Natural Gas To Propane Gas Conversion Kits

Models	Catalog No.
MPDT/R-3328	26M59
MPD-3530	26M60
MPD-4035	26M61
MPD-4540	26M62

Electronic HONEYWELL Systems Propane Gas To Natural Gas Conversion Kits

Models	Catalog No.
MPDT/R-3328	26M63
MPD-3530	26M64
MPD-4035	26M65
MPD-4540	26M66

INSTALLATION INSTRUCTIONS

Step 1. TURN OFF THE GAS SUPPLY TO THE APPLIANCE and disconnect power supply at the circuit breaker. Ensure appliance is cold.

CAUTION: THE GAS SUPPLY SHALL BE SHUT OFF PRIOR TO DISCONNECTING THE ELECTRICAL POWER, BEFORE PROCEEDING WITH THE CONVERSION.

ATTENTION: AVANT D'EFFECTUER LA CONVERSION, COUPEZ D'ABORD L'ALIMENTATION EN GAZ, ENSUITE, COUPEZ L'ALIMENTATION ÉLECTRIQUE.

Open the bottom drop-down door. Open it (see **Figure 52 on page 27**) by pushing in simultaneously the left and right top corners of the door. (The door is hinged at the bottom.) Remove the bottom compartment door by sliding the hinge pin, located at the door's left side, to the right until it disengages from the left corner post hole. Pull the door diagonally to the left, away from the fireplace.

Remove the modesty panel. To remove the modesty panel lift the modesty panel by the tab on the panel's right end, pull the right end of the panel away from cabinet and then pull the panel diagonally out of the corner post slots on the left side of the unit. Remove the modesty panel carefully, so that none of the wires become loose or disconnected. Remove the front glass door/frame from the appliance.

Step 2. Carefully remove the logs. **Exercise care so as not to break the logs.**

Step 3. Refer to **Figure 67.**

- A.** Above the burner, remove the two baffle securing screws. Remove the baffle.
- B.** Remove the two screws securing the trapezoidal plate to the burner. Remove the plate.
- C.** Remove the burner assembly with attached venturi tube.

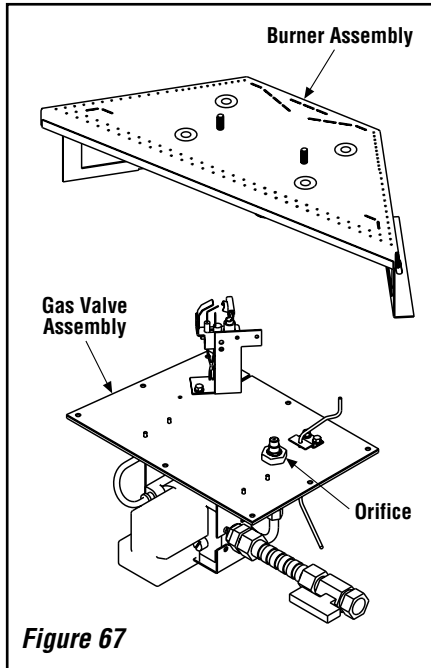

Millivolt Appliances

Step 4. SIT Systems - Refer to **Figure 68** and the instructions provided with the kit. Using a Torx T20, remove and discard the three pressure regulator mounting screws. Remove the pressure regulator, spring, poppet, diaphragm and bushing. **Discard all removed components.** Ensure the rubber gasket installed on the back of the replacement pressure regulator is properly positioned and install the new pressure regulator using the new screws supplied with the kit. Tighten screws to 25 In. lb. torque.

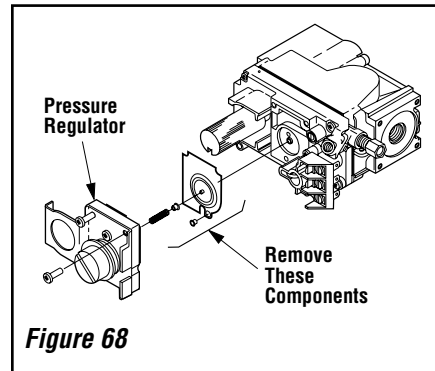

Step 5. Attach manometer to the manifold side pressure test fitting and verify manifold pressure reads 3.5 inches water column (0.87 kPa) for natural gas, and 10.0 inches water column (2.49 kPa) for propane gas.

Step 6. Refer to **Figure 69** and remove the pilot hood assembly to access the hexed pilot orifice. Remove and replace the orifice with the one provided with the kit.

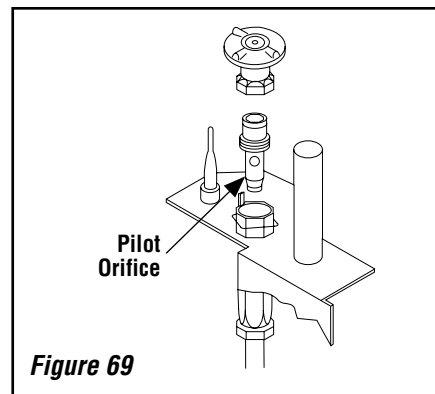

Electronic Appliances

Step 7. Honeywell Electronic Valves - See **Figure 70** and the instructions provided with the kit. Remove the slotted cap screw, o-ring, pressure-regulating adjusting screw and spring. Retain all parts for possible later use. Install new components from the kit. Black cap and red spring for propane gas units. Silver cap and stainless steel spring for natural gas units. Before installing the cap, attach manometer to the manifold side pressure test fitting and adjust screw until pressure reads 3.5 inches water column (0.87 kPa) for natural gas, and 10.0 inches water column (2.49 kPa) for propane gas.

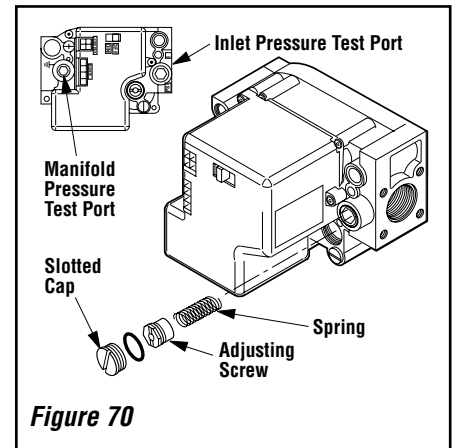

See **Figure 71** and replace the pilot orifice as follows: Remove the ignitor assembly retainer clip, and carefully remove the ignitor assembly.

Exercise extreme care to prevent damage to or breakage of the ignitor assembly. Remove the screw securing the pilot assembly to its mounting bracket. Back off the flare nut at the end of the pilot gas line to free the pilot assembly from the gas line. Remove the pilot orifice and replace it with the one provided with the conversion kit. Reinstall the pilot assembly by reversing the **steps** detailed here.

When reinstalling the ignitor assembly, use extreme care to prevent damage and breakage. Do not apply any leverage to the ignitor assembly while restoring the retainer clip to its original position.

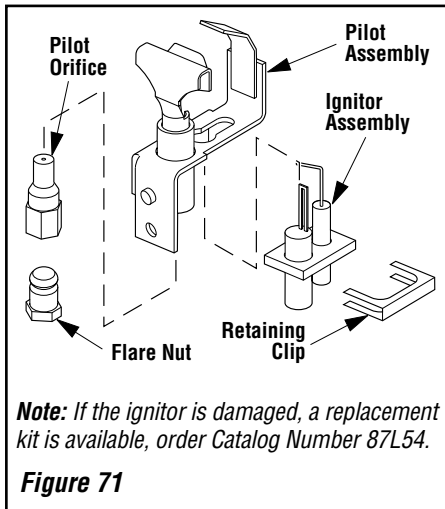

All Models

Use pipe joint compound or Teflon tape on all pipe fittings before installing (ensure propane resistant compounds are used in propane applications, do not use pipe joint compounds on flare fittings).

Step 8. (Refer to **Figure 67** on page 39)

A. Remove the orifice from the manifold and replace it with the one provided in the kit. See the following table for orifice sizes for natural and propane models. **Figure 72** illustrates the orifice.

B. Retrieve the burner and hold the venturi tube above the orifice. Place the shutter adjusting rod in the propane slot of the shutter arm (see **Figure 64** on page 34). Set the burner assembly into its position and secure the trapezoidal plate with the two screws previously removed.

C. Reinstall the baffle with the two baffle securing screws.

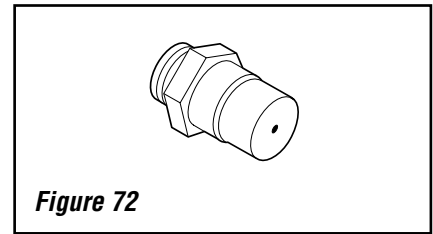

Step 9. Reassemble the remaining components by reversing the procedures outlined in the preceding steps.

Step 10. Attach the conversion label provided in the conversion kit next to the rating plate on the appliance.

Step 11. Turn on gas supply and test for gas leaks (refer to **page 27**).

Burner Orifice Sizes Elevation 0-4500 feet (0-1372 meters)		
Model Series	Nat. Gas drill size (inches)	Propane drill size (inches)
MPDT-3328 MPDR-3328	#45 (0.0820")* 39L66•	0.048 inch 99K78•
MPD-3530	#44 (0.0860")* 60J80•	#55 (0.0520")* 19L52•
MPD-4035	#37 (0.1040")* 24M10•	0.063 inch 21L01•
MPD-4540	#36 (0.1065")* 18L40•	#52 (0.0635")* 37G00•

Table 9 * Standard size installed at factory
• Part /Cat. Number

NOTE: DIAGRAMS & ILLUSTRATIONS ARE NOT TO SCALE.

Lennox Hearth Products reserves the right to make changes at any time, without notice, in design, materials, specifications, prices and also to discontinue colors, styles and products. Consult your local distributor for fireplace code information.

