

MASTER[®]

Model #s: MH-45-KFA, MH-70T-KFA,
MH-125T-KFA, MH-175T-KFA, MH-215T-KFA



CONSUMER: Retain this manual for future reference.

IMPORTANT: Read and understand all of the directions in this manual before assembling, starting, or servicing the heater. Improper use of this heater can cause serious injury. Keep this manual for future reference.

▲ DANGER GENERAL HAZARD WARNING:

Be sure to comply with the instructions and warnings provided with this heater, or death, serious bodily injury and property loss, damage from the hazards of fire, explosion, burn, asphyxiation, and carbon monoxide poisoning can result. Only persons who can follow and understand these instructions should use or service this heater. If you need heater information such as an instruction manual, labels, etcetera, contact the manufacturer.

▲ DANGER Not for use in residential living areas or in non-adequately ventilated enclosed spaces.

Pinnacle Products International, Inc. 668 Stony Hill Road #302 Yardley, PA 19067 USA
Phone: 215-891-8460 Fax: 215-891-8461 Web: www.pinnacleint.com Email: info@pinnacleint.com

**NEVER LEAVE HEATER
UNATTENDED WHILE BURN-
ING OR WHILE CONNECTED
TO A POWER SOURCE**

MASTER®

Kerosene Forced Air Heaters

Table of Contents

Safety Information	2-3
Features	3
Specifications	4
Unpacking	5
Assembly.....	5-6
Operation	6-8
Fuels	6
Theory of Operation.....	7
Ventilation.....	7
Long Term Storage.....	8
Maintenance.....	9-11
Exploded Parts Drawing.....	12
Replacement Part Listing	13
Wiring Diagrams.....	14
Troubleshooting.....	15
Warranty	Back Page

Safety Information

▲ DANGER *Indicates an imminently hazardous situation which, if not avoided, WILL result in death or serious injury.*

▲ WARNING *Indicates a potentially hazardous situation which, if not avoided, COULD result in death or serious injury.*

▲ CAUTION *Indicates a potentially hazardous situation which, if not avoided, MAY result in minor or moderate injury.*

This is a kerosene, direct-fired, forced air heater. It is primarily intended for use for temporary heating of buildings under construction, alteration or repair. Direct-fired means that all of the combustion products of the heater enter the heated space. This appliance is rated at 98% combustion efficiency, but does produce small amounts of carbon monoxide. Carbon monoxide is toxic.

▲ DANGER *Carbon Monoxide poisoning may lead to death!*

Humans can tolerate small amounts of carbon monoxide, and precautions should be taken to provide proper ventilation. Failure to provide proper ventilation according to this manual can result in death. Early signs of carbon monoxide poisoning resemble the flu. Symptoms of improper ventilation are:

*** headache * dizziness * burning of the nose and eyes
* nausea * dry mouth * sore throat**

For optimal performance of this heater, it is strongly suggested that 1-K kerosene be used. 1-K kerosene has been refined to virtually eliminate contaminants, such as sulfur, which can cause a rotten egg odor during the operation of the heater. However, #1 or #2 fuel oil (diesel fuel) may also be used if 1-K kerosene is not available. Be advised that these fuels do not burn as clean as 1-K kerosene, and care should be taken to provide more fresh air ventilation to accommodate any added contaminants that may be added to the heated space. Use of #1 or #2 fuel oil may result in more periodic maintenance.

▲ WARNING *Risk of indoor air pollution!*

- Use this heater only in well ventilated areas! Provide at least a three square foot (2,800 sq cm) opening of outside air for every 100,000 BTU/hr of heater rating.

- People with breathing problems should consult a physician before using the heater.

- Carbon Monoxide Poisoning: Early signs of carbon monoxide poisoning resemble flu-like symptoms such as headaches, dizziness, and/or nausea. If you have these symptoms, your heater may not be working properly.

- Get fresh air at once! Have the heater serviced. Some people are more affected by carbon monoxide than others. These include pregnant women, those with heart or lung problems, anemia, or those under the influence of alcohol, or at high altitudes.

▲ WARNING *Risk of burns / fire / explosion!*

- NEVER use fuels such as gasoline, benzene, paint thinners, or other oil compounds in this heater (RISK OF FIRE OR EXPLOSION).

▲ WARNING Fire, burn, inhalation, and explosion hazard. Keep combustibles, such as building materials, paper or cardboard, a safe distance away from the heater as recommended by these instructions. Never use the heater in spaces which contain products such as gasoline, solvents, paint thinners, dust particles, volatile or airborne combustibles, or any unknown chemicals. This is an unvented portable heater. It uses air (oxygen) from the area in which it is used. Adequate combustion and ventilation air must be provided. Refer to VENTILATION on Page 7.

▲ WARNING Do not operate this heater until you have read, and thoroughly understand these safety and operating instruction. Failure to comply with the precautions and instructions provided with this heater can result in death, serious bodily injury, property loss or damage from the hazards of fire, soot production, explosion, burns, asphyxiation or carbon monoxide poisoning. Only persons who can read and understand these instructions should use or service this heater.

Not for use in homes or recreational vehicles.

California Residents: Combustion by-products produced when using this product contain carbon monoxide, a chemical known to the state of California to cause cancer and birth defects (or other reproductive harm).

Massachusetts Residents: Massachusetts state law prohibits the use of this heater in any building which is used in whole or in part for human habitation. Use of this heating device in Massachusetts requires local fire department permit (M.G.L.C. 148, Section 10A).

New York City Residents: The New York City Fire Code prohibits the storage, handling and use of kerosene fueled heaters for space heating. Any person violating that provision may be punished by a fine up to \$10,000 and a term of imprisonment up to 6 months.

**NEVER LEAVE HEATER
UNATTENDED WHILE BURN-
ING OR WHILE CONNECTED
TO A POWER SOURCE**

MASTER®

Kerosene Forced Air Heaters

Safety Information (Continued)

- NEVER refill the heater's fuel tank while heater is operating or still hot. This heater is EXTREMELY HOT while in operation.
- Keep all combustible materials away from this heater.
- NEVER block air inlet (rear) or air outlet (front) of heater.
- NEVER use duct work in front or at rear of heater.
- NEVER move or handle heater while still hot.
- NEVER transport heater with fuel in its tank.
- If equipped with a thermostat, the heater may start at any time.
- ALWAYS locate heater on a stable and level surface.
- ALWAYS keep children and animals away from heater.
- Bulk fuel storage should be a minimum of 25 ft. from heaters, torches, portable generators, or other sources of ignition. All fuel storage should be in accordance with federal, state, or local authorities having jurisdiction.

- Never use this heater in living or sleeping areas.
- NEVER use this heater where flammable vapors may be present.

▲WARNING *Risk of electric shock!*

- Use only the electrical power (voltage and frequency) specified on the model plate of the heater. Use only a three-prong, grounded outlet and extension cord.
- ALWAYS install the heater so that it is not directly exposed to water spray, rain, dripping water, or wind.
- ALWAYS unplug the heater when not in use.

Minimum clearance from Combustibles:

	45k	70k	125k	175k	215k
Top	4 ft.	4 ft.	4 ft.	4 ft.	4 ft.
Sides	4 ft.	4 ft.	4 ft.	4 ft.	4 ft.
Front	8 ft.	8 ft.	8 ft.	8 ft.	8 ft.

Features

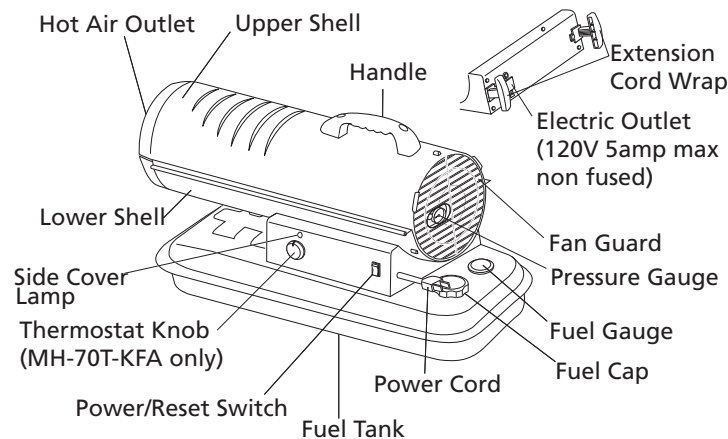

Figure 1. Features of Models MH-45/70T-KFA

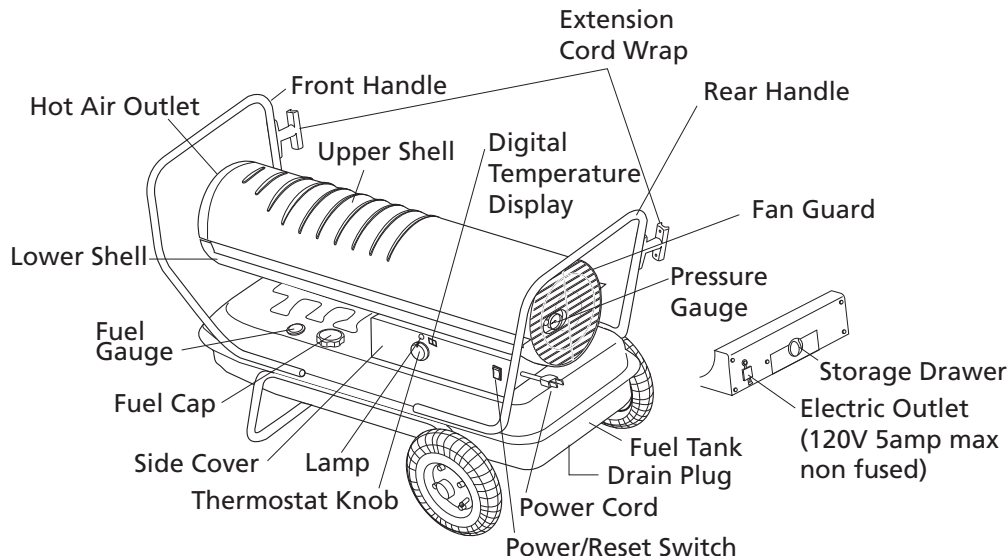

Figure 2. Features of Model MH-125T / 175T / 215T-KFA

**NEVER LEAVE HEATER
UNATTENDED WHILE BURN-
ING OR WHILE CONNECTED
TO A POWER SOURCE**

MASTER

**Kerosene
Forced Air Heaters**

Specifications

Model #	MH-45-KFA	MH-70T-KFA	MH-125T-KFA	MH-175T-KFA	MH-215T-KFA
Rating BTU/Hr	45,000	70,000	125,000	175,000	215,000
Fuel Consumption Gal/Hr	0.35	0.53	.95	1.34	1.63
Fuel Tank Capacity Gallons	5.0	5.0	10.0	13.0	13.0
Pump Pressure PSI	3.0	4.0	5.0	7.5	9.0
Volt/Hz	120VAC/60 Hz	120VAC/60 Hz	120VAC/60 Hz	120VAC/60 Hz	120VAC/60 Hz
Amps	1.4	1.5	2.3	2.7	2.8
Phase	Single	Single	Single	Single	Single
Size (L x W x H)	30" x 12" x 15"	30" x 12" x 15"	39" x 23" x 26"	43" x 24" x 26"	43" x 24" x 26"
Net Weight (Lbs)	28	28	54	61	64

Specifications subject to change without notice

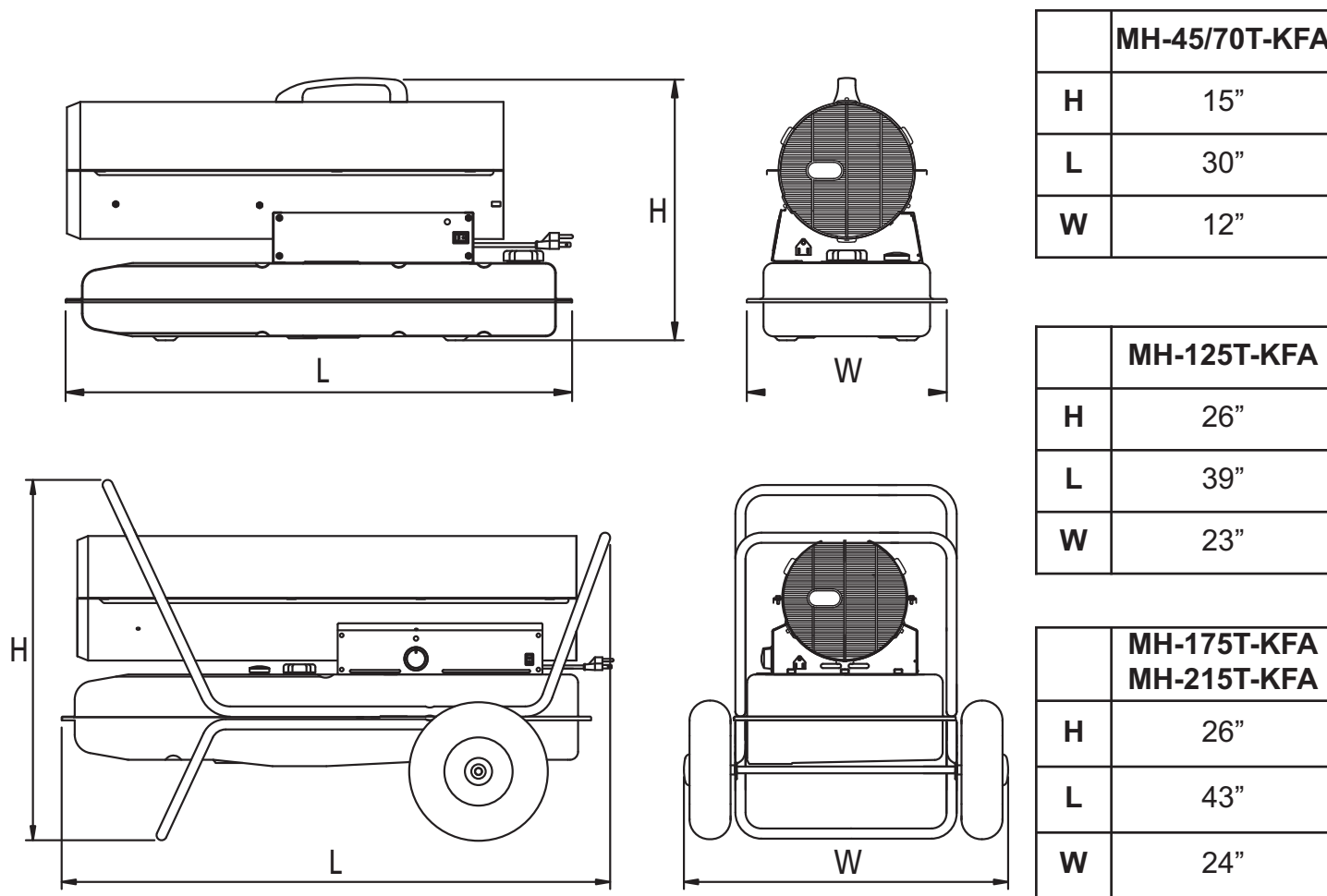

Figure 3. Product Dimensions

**NEVER LEAVE HEATER
UNATTENDED WHILE BURN-
ING OR WHILE CONNECTED
TO A POWER SOURCE**

MASTER®

Kerosene Forced Air Heaters

Unpacking

Remove the heater and all of the packaging materials from the shipping carton.

NOTE: Save the box and packaging materials for future storage.

Check the chart below to be sure that you have all of the parts required to assembly your heater. If you find that any parts are missing, call 215-891-8460 for assistance in receiving the missing components.

Assembly

	45-KFA	70T-KFA	125T-KFA	175T-KFA	215T-KFA
Wheel support frame	NO	NO	YES	YES	YES
Wheel (2 pieces)	NO	NO	YES	YES	YES
Front and Rear Handle	NO	NO	YES	YES	YES
Axle	NO	NO	YES	YES	YES
Top Handle	YES	YES	NO	NO	NO
Screws & Nuts (A) 8 each	NO	NO	YES	YES	YES
Screws & Nuts (B) 4 each	YES	YES	NO	NO	NO
Cotter Pins, Bushings, Washers (L & S)	NO	NO	YES	YES	YES
Cord Wrap	YES	YES	YES	YES	YES

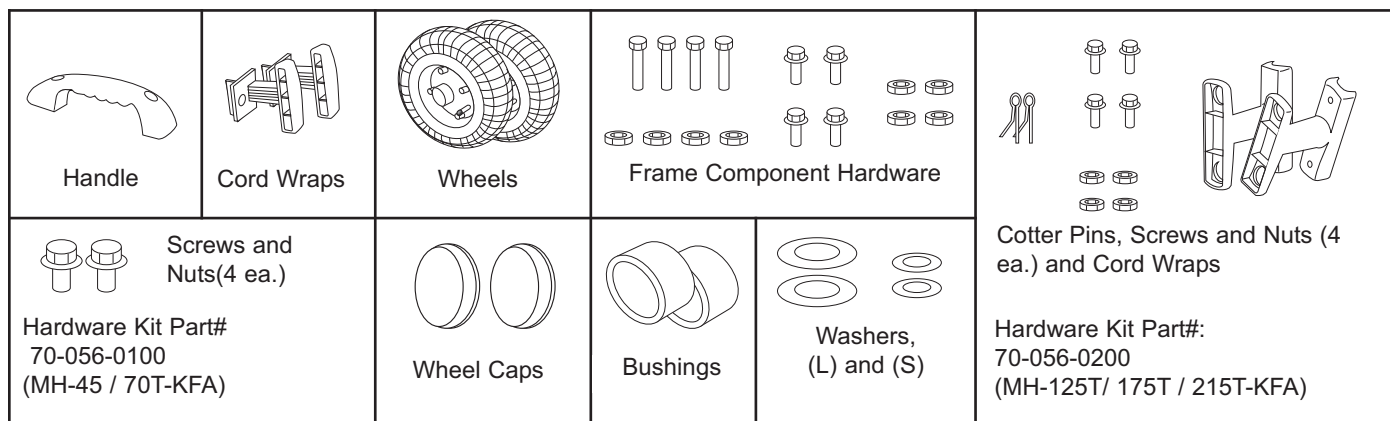

Figure 4. Hardware Components

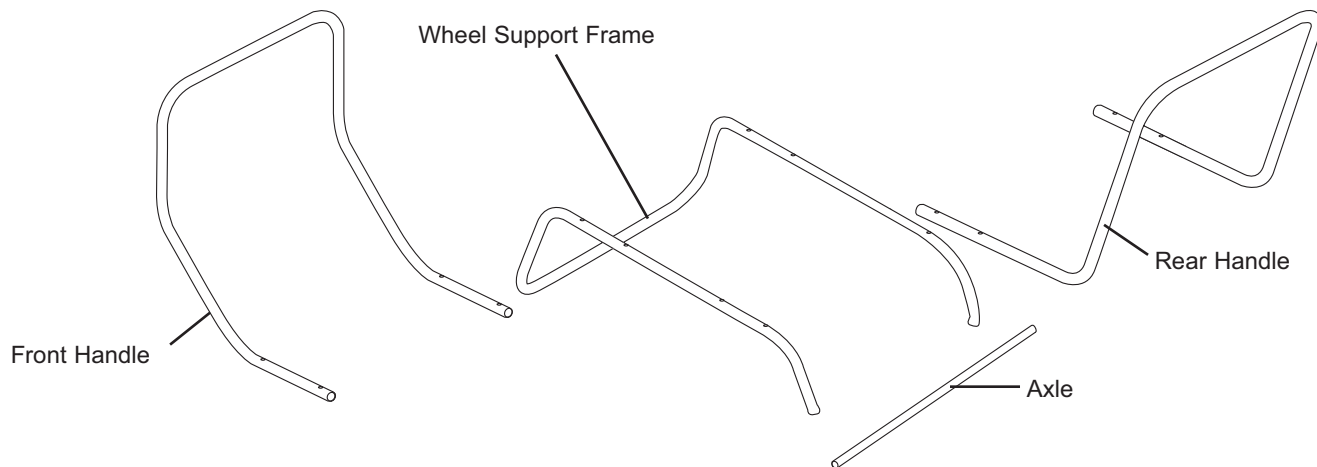

Figure 5. Frame components, Models MH-125T/175T/215T-KFA

**NEVER LEAVE HEATER
UNATTENDED WHILE BURN-
ING OR WHILE CONNECTED
TO A POWER SOURCE**

MASTER®

Kerosene Forced Air Heaters

Assembly Continued

MODELS MH-45/70T-KFA ONLY

- **Tools required:** Medium phillips screw driver.

ASSEMBLING HANDLE

1. Align the holes in the upper housing with the 2 holes in the handle as shown in **Figure 6**.
2. Insert and tighten screws securely with screw driver.

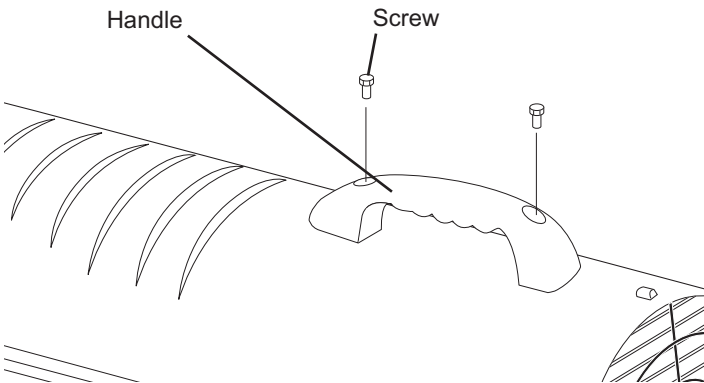

Figure 6. Handle Mounting, Models MH-45/70T-KFA

ASSEMBLING CORDWRAP

1. Insert tabs on cordwrap into slots in shell support, lining up the holes on the cordwrap with those on the side cover.
2. Insert and tighten screws securely with screw driver.

MODELS MH-125T/175T/215T-KFA ONLY

- **Tools required:** Medium phillips screw driver, 5/16" open end or adjustable wrench, needle nose pliers.

ASSEMBLING FRAME AND WHEELS

1. Slide axle through holes in wheel support frame. Slide wheel bushings and flat washer (A) on to each end of axle.
2. Slide wheels on to each axle, being sure that the valve stem (if pneumatic) is to the outside (**see Figure 7**).
3. Slide flat washers (B) onto axle past the small hole. Insert cotter pin in axle hole and bent legs of pin with needle nose pliers to secure.
4. Snap the wheel caps onto the large washers (B).
5. Place heater on the assembled frame, making sure that the air inlet end is by the wheels, and the mounting holes on the tank flange of the heater align with holes in frame.
6. Take the front handle and align the mounting holes with the corresponding holes in the tank flange/wheel frame. Slide a screw (A) through the holes and loosely attach a nut. Repeat for the other 3 holes, then fully tighten all 4 screws and nuts.
7. Repeat this process with the rear handle.

NOTE: The front handle is longer than the rear handle.

ASSEMBLING CORDWRAP

1. Align holes in cordwrap with corresponding holes in front handle. Insert screws (B) through holes, attach nuts and tighten (see **Figure 7**).
2. Repeat this process with the rear handle.

CAUTION Do not operate heater without support frame fully assembled to tank.

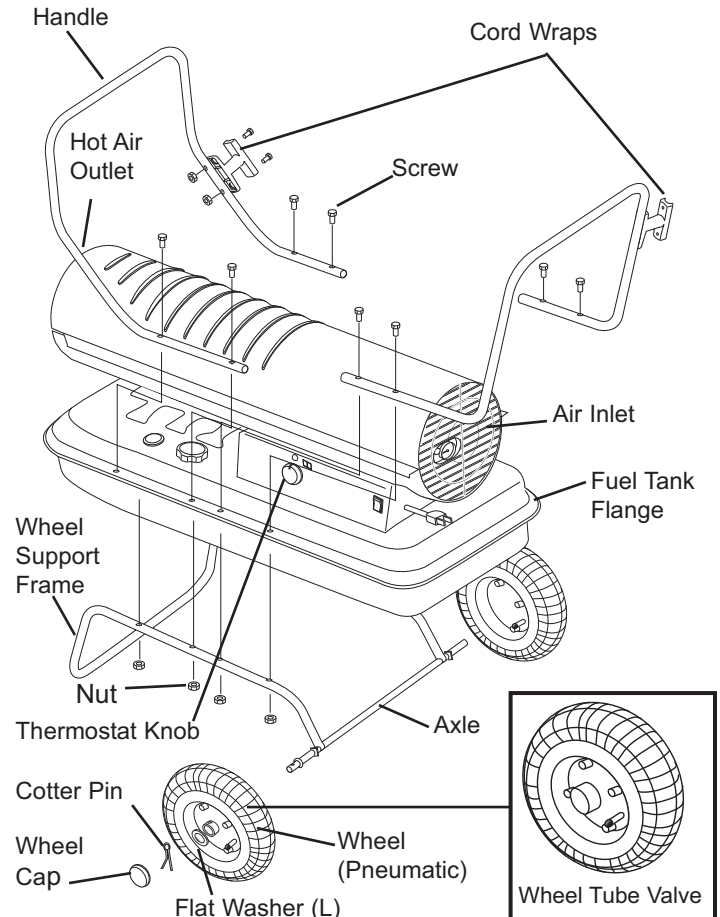

Figure 7. Assembly of Models MH-125T/175T/215T-KFA

Operation

KEROSENE (1-K)

For optimal performance of this heater, it is strongly suggested that 1-K kerosene be used. 1-K kerosene has been refined to virtually eliminate contaminants, such as sulfur, which can cause a rotten egg odor during the operation of the heater. However, #1 or #2 fuel oil (diesel fuel) may also be used if 1-K kerosene is not available. Be advised that these fuels do not burn as clean as 1-K kerosene, and care should be taken to provide more fresh air ventilation to accommodate any added contaminants that may be added to the heated space. **Using diesel fuel can cause excess soot production.** DO NOT use any fuel that is not approved above.

**NEVER LEAVE HEATER
UNATTENDED WHILE BURN-
ING OR WHILE CONNECTED
TO A POWER SOURCE**

MASTER®

Kerosene Forced Air Heaters

Operation (Continued)

NOTE: Kerosene should only be stored in a blue container that is clearly marked "kerosene". Never store kerosene in a red container. Red is associated with gasoline.

- NEVER store kerosene in the living space. Kerosene should be stored in a well ventilated area outside the living area.
- NEVER use fuel such as gasoline, benzene, alcohol, white gas, camp stove fuel, paint thinners, or other oil compounds in this heater (THESE ARE VOLATILE FUELS THAT CAN CAUSE A FIRE OR EXPLOSION).
- NEVER store kerosene in direct sunlight or near a source of heat.
- NEVER use kerosene that has been stored from one season to the next. Kerosene deteriorates over time. OLD KEROSENE WILL NOT BURN PROPERLY IN THIS HEATER.
- Use 1-K kerosene in this heater. #1 fuel is a suitable substitute.

THEORY OF OPERATION

Fuel System: This heater is equipped with an air pump that operates off of the electric motor. The pump forces air through the air line connected to the fuel tank, drawing fuel to the nozzle in the burner head. Air also passes through the nozzle where it mixes with the fuel and is sprayed into the combustion chamber in a fine mist.

Quick-Fire Ignition: A transformer sends high voltage to a two pronged spark plug. The spark ignites the fuel/air mixture as it is sprayed into the combustion chamber.

Air System: A fan is turned by the heavy duty motor, which forces air around and into the combustion chamber, where it is super-heated and forced out the front of the chamber.

Temperature Limit Control: This heater is equipped with a Temperature Limit Control designed to turn the heater off should the internal temperature rise to an unsafe level. If this device activates and turns your heater off, it may require service.

Once the temperature falls below the reset temperature, you will be able to start your heater.

Electrical System Protection: The heaters' electrical system

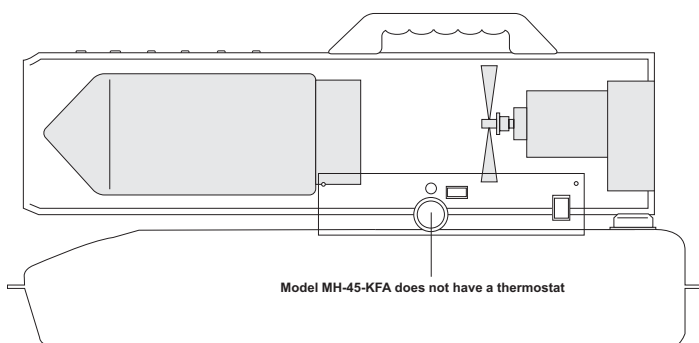

Figure 8. Theory of Operation

is protected by a circuit breaker that protects the system components from damage. If the heater fails, check the fuse first, and replace if necessary.

Flame Sensor: The heater uses a photocell to "see" the flame in the combustion chamber. Should the flame extinguish, the sensor will stop electrical current and the heater will shut off.

FUELING THE HEATER

CAUTION NEVER FILL THE FUEL TANK INDOORS. ALWAYS FILL THE TANK OUTDOORS. BE SURE THAT THE HEATER IS ON LEVEL GROUND WHEN FUELING, AND NEVER OVERFILL THE FUEL TANK.

WARNING NEVER REFUEL THIS HEATER WHILE IT IS HOT OR OPERATING. FIRE OR EXPLOSION COULD RESULT.

It is always a good idea to fire the heater outdoors for the first time. This will allow any oils used in the manufacturing process to be burned off in a safe environment. This initial burn should last at least 10 minutes

VENTILATION

Risk of indoor air pollution. Use heater only in well ventilated areas.

- Always provide a fresh air opening in the heated space of at least three square feet (2,800 sq. cm) for each 100,000 BTU/Hr. of heater output. Provide a larger opening if more heaters are being used. As an example, an MH-215T-KFA heater will require:
- a two-car garage door open 6 inches, or
 - a single car garage open 9 inches, or
 - two thirty two inch wide windows open fifteen inches.

TO START THE HEATER

1. Fill the tank with kerosene until fuel gauge points to "F".
2. Be sure fuel cap is secure.
3. Plug power cord into three prong, grounded extension cord and plug extension cord into three prong 120V grounded outlet. The extension cord should be at least six feet long.
 - Extension cord wire size requirements are as follows:
 - 6 to 10 feet (1.8 to 3 meters), use 18 AWG wire.
 - 11 to 100 feet (3.4 to 30.4 meters), use 16 AWG wire.
 - 101 to 200 feet (30.8 to 61 meters), use 14 AWG wire.
4. Turn thermostat control knob to desired temperature setting (70/125/175/215 only). The setting range is from 40° F to 110° F. Push the Power switch to the "ON" position (See figure 9). The power indicator lamp and room temperature display (125/175/215 only) will light and the heater will start.

NOTE: The room temperature display (125/175/215 only) will indicate the following:

- When temperature is less than 0° F, display says "LO".
- When temperature is above 99° F, display says "HI".
- Between 0° and 99° F display shows actual temperature.

NEVER LEAVE HEATER UNATTENDED WHILE BURNING OR WHILE CONNECTED TO A POWER SOURCE

MASTER

Kerosene Forced Air Heaters

Operation (Continued)

If the heater does not fire, the thermostat may be set too low. Turn the Control Knob to a higher setting until heater fires. If the heater still does not start, push Power Switch to "OFF", then back to "ON". If heater still does not fire, see Troubleshooting Guide on Page 15.

NOTE: The electrical components of this heater are protected by a fuse mounted in the PC board. If the heater fails to fire, check this fuse first, and replace if necessary. Also check the power source to be sure that the proper voltage is being provided to the heater.

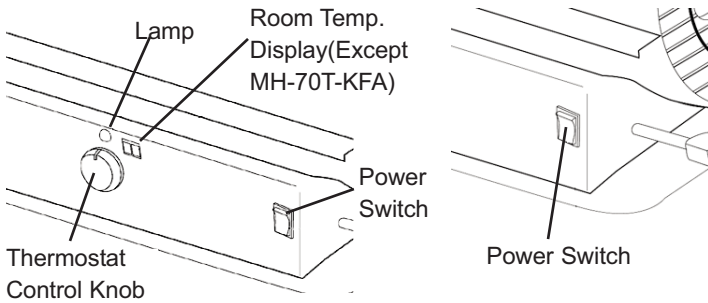

Models MH-70T / 125T / 175T / 215T-KFA Model MH-45-KFA

Figure 9. Control Panel for all Models

TO STOP THE HEATER

Simply turn the Power switch to "OFF" position and unplug the Power Cord.

TO RESTART THE HEATER

1. Wait ten seconds after shutting off heater.
2. Turn the Power Switch to "ON" position.
3. Be sure to follow all starting procedure precautions.

ELECTRICAL OUTLET

⚠ WARNING Shock Hazard!

- Never plug in an appliance with more than a 5 amp rating into this outlet.
- Always keep outlet covered when not in use.

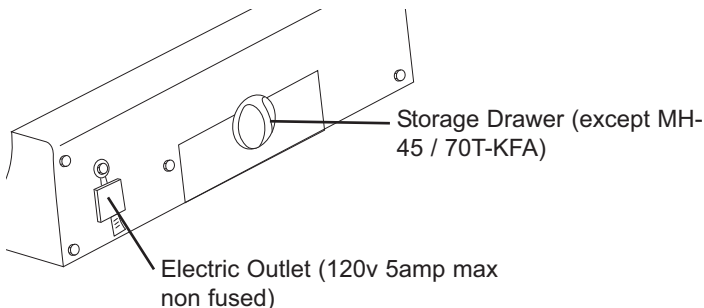

Figure 10. Electric Outlet Detail

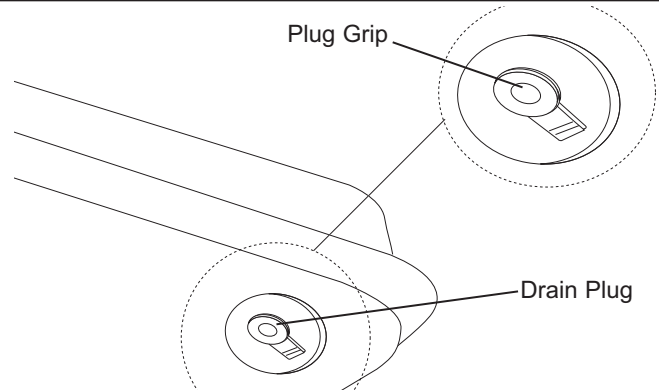

Figure 11. Drain Plug Removal

LONG TERM STORAGE

Drain Fuel Tank

For models MH-45/70T-KFA, drain fuel through the fuel cap opening using an approved siphon. For models MH-125/175/215-KFA, drain fuel through the Drain Plug at the bottom of the Fuel Tank.

2. To remove the Drain Plug (125/175/215), pull the Plug Grip downward and remove seal head from drain hole in tank (See Figure 11).
3. Using a small amount of kerosene, rinse and swirl the kerosene inside of the Fuel Tank. Empty the tank fully.
4. To replace, push the drain head fully into the drain hole and secure by pushing the seal cap fully into the head hole (See Figure 12).

IMPORTANT: Never store leftover kerosene over the summer. Using old fuel can damage your heater.

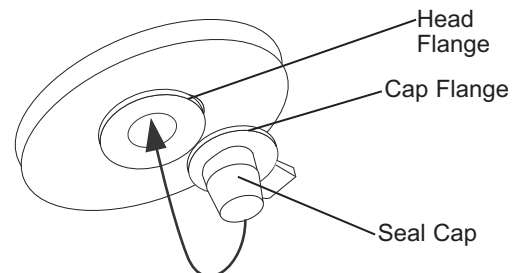
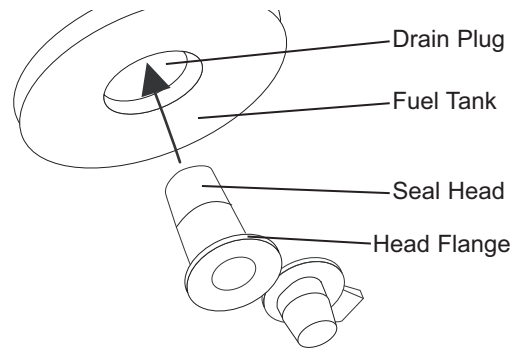

Figure 12. Drain Plug Reinstall

NEVER LEAVE HEATER UNATTENDED WHILE BURNING OR WHILE CONNECTED TO A POWER SOURCE

MASTER

Kerosene Forced Air Heaters

Store heater in a dry, well-ventilated area

Be sure that the storage area is free of dust and corrosive vapors. Repack the heater in the original shipping material. Keep the Users Manual in an easily accessible place.

⚠ WARNING Maintenance
Never service heater while it is plugged in or while hot!

Use only original equipment replacement parts. The use of alternate or third party components can cause unsafe operating conditions, and will void your warranty.

We suggest following a maintenance schedule as follows:

FUEL/FUEL TANK:

Flush every 200 hours of operation or as needed. Do not use water to flush the tank. Use fresh 1-K kerosene only.

AIR FILTERS:

The *Air Intake Filter* should be replaced or washed with soap and water and dried thoroughly every 500 hours of operation, or less, depending on conditions.

The *Output* and *Lint Filters* should be replaced every 500 hours

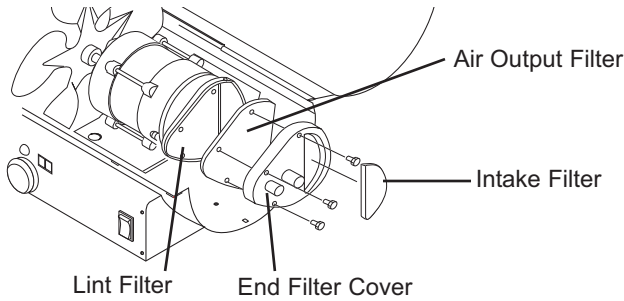

Figure 13. Filter Replacement

of operation or less, depending on conditions.

NOTE: Use of diesel may require additional maintenance.

FAN BLADES:

Blades should be cleaned at least once per heating season, depending on conditions.

Remove all accumulated dust and dirt with a damp cloth, taking care not to bend any of the fan blades. Be sure fan blades are

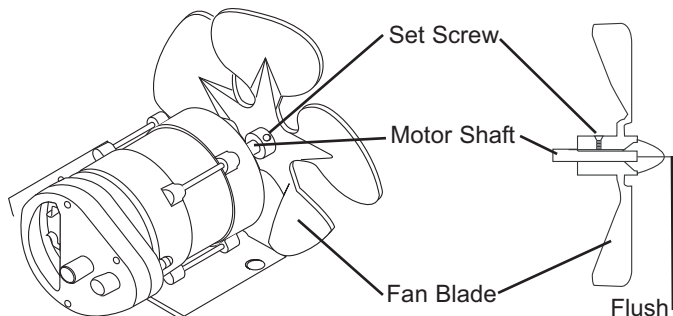

dry before re- **Figure 14. Fan Replacement**

starting the heater. For Fan removal, see **Figure 14.**

NOZZLES:

Nozzles should be cleaned or replaced at least once per heating season. Contaminated fuel could make this necessary immediately.

To clean dirt from nozzle, blow compressed air through nozzle front. It may be necessary to soak nozzle in clean 1-K kerosene

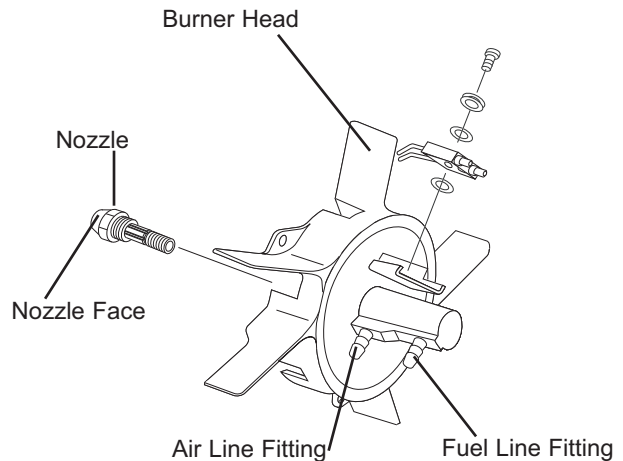
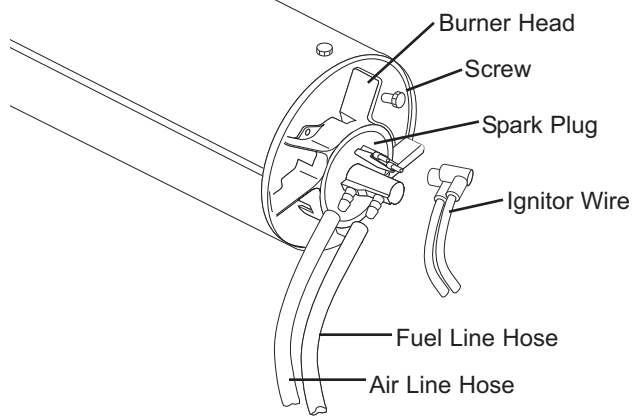

Figure 15. Nozzle Replacement

to help loosen any particles.

NOTE: Use of diesel may require additional maintenance. Using this heater without proper maintenance or with contaminated or old fuel may lead to improper combustion and possible soot production. **BE SURE FUEL USED IS APPROVED** (see OPERATION on page 6).

NEVER LEAVE HEATER UNATTENDED WHILE BURNING OR WHILE CONNECTED TO A POWER SOURCE

MASTER®

Kerosene Forced Air Heaters

Maintenance (Continued)

SPARK PLUG:

Clean and re-gap every 600 hours of operation, or replace as needed. After removing the Spark Plug, clean the terminals with a wire brush. Re-gap the terminals to 0.140" (3.5mm).

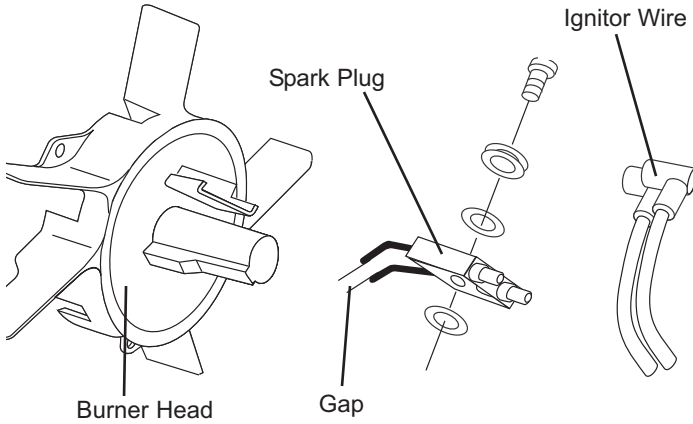

Figure 16. Spark Plug Replacement

PHOTOCELL:

The Photocell should be cleaned at least once per heating season or more depending on conditions. Use a cotton swap dipped in water or alcohol to clean the lens of the Photocell. Note the proper Photocell position as noted in **Figure 17** and **Figure 18**.

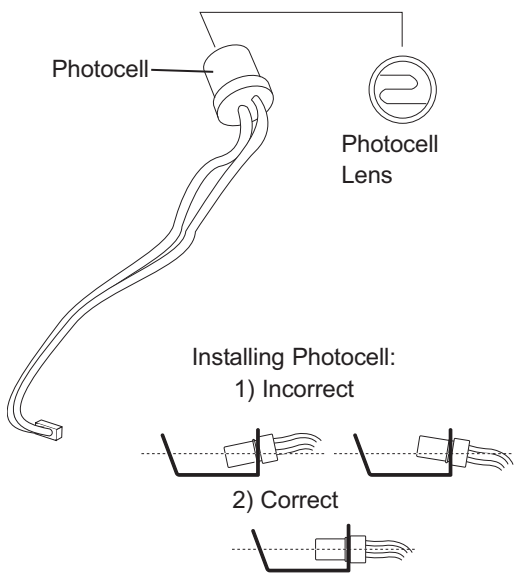

Figure 17. Photocell Positioning

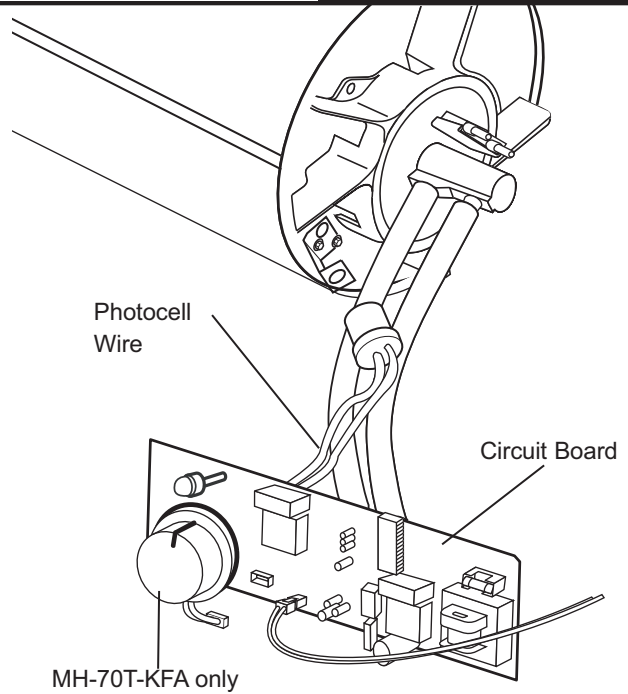

Figure 18. Photocell Position for MH-45 / 70T-KFA
FUEL FILTER:
The Fuel Filter should be cleaned at least twice per heating season by rinsing it in clean 1-K kerosene. Contaminated fuel could make this necessary immediately (See **Figure 19**).

NOTE: To remove the filter from models MH-45 / 70T-KFA, turn filter 90° clockwise. To remove the filter from models MH-125T / 175T / 215T-KFA, turn filter 90° counter-clockwise. Use of diesel may require additional maintenance. **Improper maintenance can lead to poor combustion and soot production.**

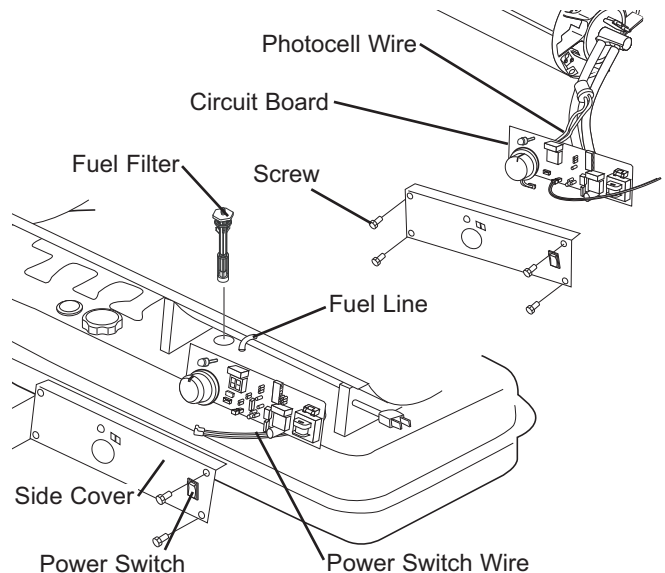

Figure 19. Fuel Filter Replacement

NEVER LEAVE HEATER
UNATTENDED WHILE BURN-
ING OR WHILE CONNECTED
TO A POWER SOURCE

MASTER®

Kerosene Forced Air Heaters

Maintenance (Continued)

PUMP PRESSURE ADJUSTMENT:

While heater is operating, turn relief valve clockwise to increase, counterclockwise to decrease (see **Figure 20**). Use flat blade screwdriver to turn valve. Correct pump pressure is as follows:

Model #	Pump Pressure
MH-45-KFA	3.0 PSI
MH-70T-KFA	4.0 PSI
MH-125T-KFA	5.0 PSI
MH-175T-KFA	7.5 PSI
MH-215T-KFA	9.0 PSI

Tolerance $\pm 10\%$

For best measurement of pressure, test with full tank of fuel. **Optimum pressure occurs when the nose cone is cherry red and there are no extending flames from the heater.**

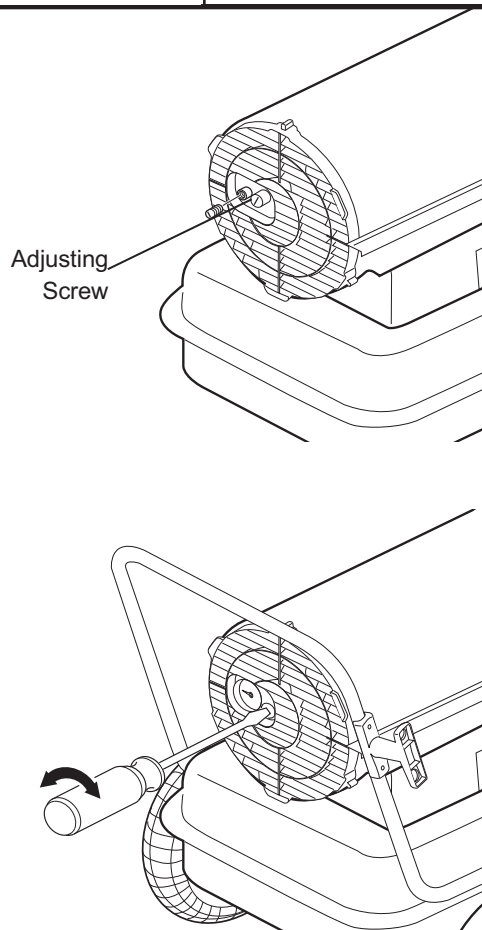

Figure 20. Pump Pressure Adjustment

NEVER LEAVE HEATER
UNATTENDED WHILE BURN-
ING OR WHILE CONNECTED
TO A POWER SOURCE

MASTER®

Kerosene Forced Air Heaters

Exploded Drawing Part Breakdown

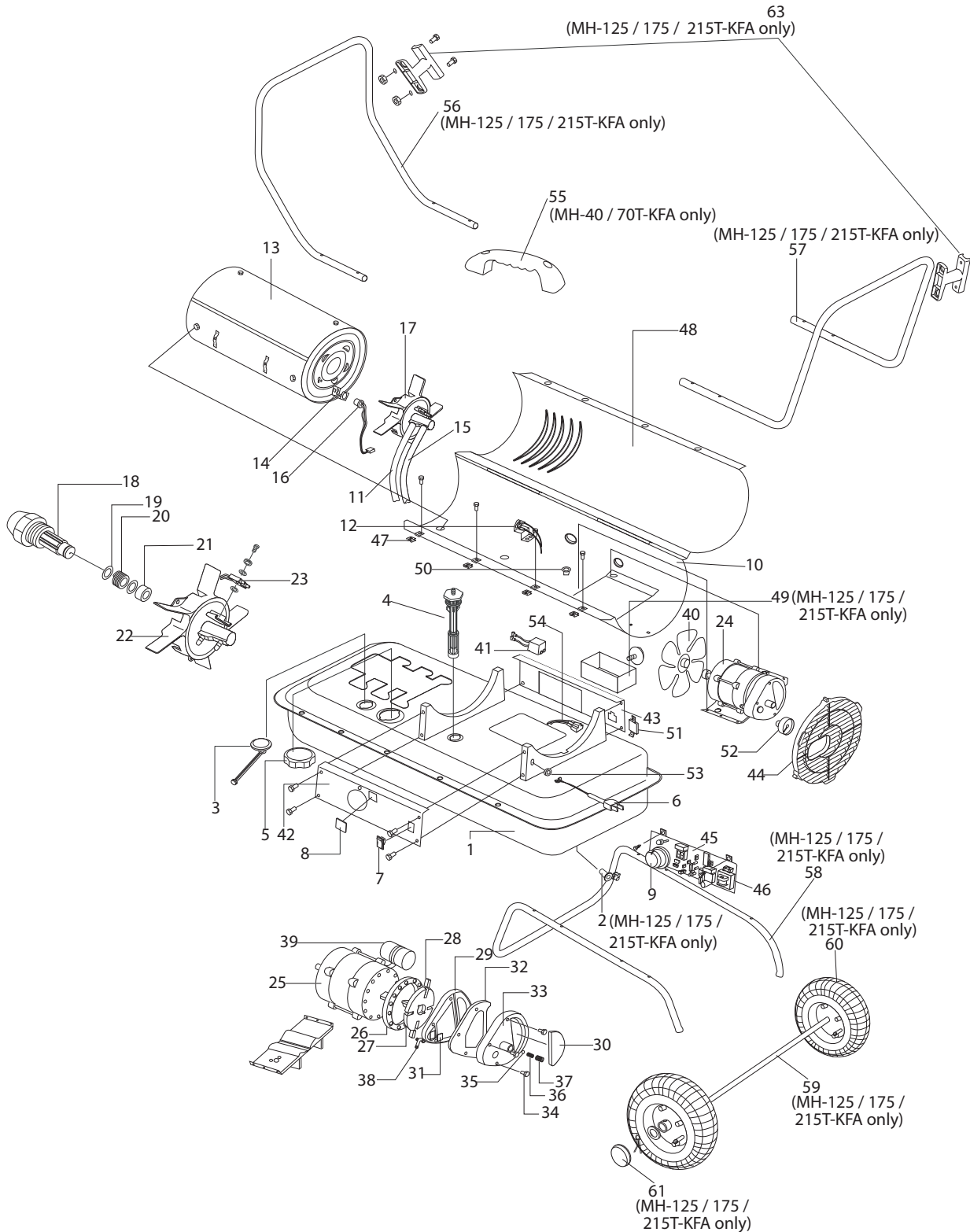

Figure 21. Exploded View Models MH-45/70T/125T/175T/215T-KFA

**NEVER LEAVE HEATER
UNATTENDED WHILE BURN-
ING OR WHILE CONNECTED
TO A POWER SOURCE**

MASTER®

**Kerosene
Forced Air Heaters**

Ref. No.	Description	Part Number for Models:				
		MH-45-KFA	MH-70T-KFA	MH-125T-KFA	MH-175T-KFA	MH-215T-KFA
1	Fuel Tank Assembly	70-002-0100	70-002-0100	70-002-0200	70-002-0300	70-002-0300
2	Drain Plug	—	—	70-002-0105	70-002-0105	70-002-0105
3	Fuel Gauge Assembly	70-007-0100	70-007-0100	70-007-0200	70-007-0200	70-007-0200
4	Fuel Filter Assembly	70-003-0100	70-003-0100	70-003-0200	70-003-0200	70-003-0200
5	Fuel Cap	70-006-0100	70-006-0100	70-006-0100	70-006-0100	70-006-0100
6	Power Cord	70-034-0100	70-034-0100	70-034-0200	70-034-0200	70-034-0200
7	Power Switch	70-038-0100	70-038-0100	70-038-0100	70-038-0100	70-038-0100
8	Window Display	—	—	70-040-0100	70-040-0100	70-040-0100
9	Thermostat Control Knob	—	70-031-0100	70-031-0100	70-031-0100	70-031-0100
10	Lower Shell	—	—	—	—	—
11	Air Line	70-035-0100	70-035-0200	70-035-0300	70-035-0400	70-035-0500
12	Thermostat Limit Control	70-019-0100	70-019-0100	70-019-0100	70-019-0100	70-019-0200
13	Combustion Chamber Assembly	70-011-0100	70-011-0200	70-011-0300	70-011-0400	70-011-0500
14	Photocell Bracket	70-010-0101	70-010-0101	70-010-0101	70-010-0101	70-010-0101
15	Fuel Line	70-036-0100	70-036-0200	70-036-0300	70-036-0400	70-036-0500
16	Photocell Assembly	70-016-0100	70-016-0100	70-016-0100	70-016-0100	70-016-0100
17	Burner Head Assembly	70-014-0100	70-014-0200	70-014-0300	70-014-0400	70-014-0500
18	Nozzle Kit	70-015-0100	70-015-0200	70-015-0300	70-015-0400	70-015-0500
19	Nozzle Seal Washer	—	—	—	—	—
20	Nozzle Seal Spring	—	—	—	—	—
21	Nozzle Sleeve	—	—	—	—	—
22	Burner Head	—	—	—	—	—
23	Spark Plug Kit	70-052-0100	70-052-0100	70-052-0200	70-052-0200	70-052-0200
24	Motor and Pump Assembly	70-020-0100	70-020-0100	70-020-0300	70-020-0400	70-020-0500
25	Motor	—	—	—	—	—
26	Pump Body	70-020-0101	70-020-0101	70-020-0101	70-020-0101	70-020-0401
27	Rotor Kit	70-022-0100	70-022-0100	70-022-0100	70-022-0100	70-022-0200
28	Blade	—	—	—	—	—
29	End Pump Cover	70-020-0102	70-020-0102	70-020-0102	70-020-0102	70-020-0102
30	Filter Kit	70-054-0100	70-054-0100	70-054-0100	70-054-0100	70-054-0100
31	Lint Filter	—	—	—	—	—
32	Output Filter	—	—	—	—	—
33	End Filter Cover	70-020-0103	70-020-0103	70-020-0103	70-020-0103	70-020-0103
34	Plug/Pump Adjustment Kit	70-055-0100	70-055-0100	70-055-0100	70-055-0100	70-055-0100
35	Ball	—	—	—	—	—
36	Spring	—	—	—	—	—
37	Adjusting Screw	—	—	—	—	—
38	Nipple	70-014-0104	70-014-0104	70-014-0104	70-014-0104	70-014-0104
39	Capacitor	70-020-0107	70-020-0107	70-020-0201	70-020-0201	70-020-0201
40	Fan Assembly	70-024-0100	70-024-0200	70-024-0300	70-024-0400	70-024-0400
41	Ignitor	70-037-0300	70-037-0300	70-037-0300	70-037-0300	70-037-0300
42	Right Side Cover	70-008-0100	70-008-0200	70-008-0300	70-008-0400	70-008-0450
43	Left Side Cover	70-009-0100	70-009-0100	70-009-0200	70-009-0300	70-009-0300
44	Fan Guard	70-016-0700	70-016-0700	70-016-0200	70-016-0200	70-016-0220
45	Main PCB Assembly	70-027-0100	70-027-0200	70-027-0300	70-027-0300	70-027-0300
46	Fuse	70-027-0101	70-027-0101	70-027-0101	70-027-0101	70-027-0101
47	Clip Nut	70-001-0105	70-001-0105	70-001-0105	70-001-0105	70-001-0105
48	Upper Shell	—	—	—	—	—
49	Storage Box	—	—	70-053-0100	70-053-0100	70-053-0100
50	Bushing Grommet	70-017-0100	70-017-0100	70-017-0100	70-017-0100	70-017-0100
51	Socket Cover	70-030-0100	70-030-0100	70-030-0100	70-030-0100	70-030-0100
52	Air Pressure Gauge	70-025-0100	70-025-0100	70-025-0100	70-025-0100	70-025-0100
53	Cord Bushing	70-033-0100	70-033-0100	70-033-0200	70-033-0200	70-033-0200
54	Electric Outlet	70-029-0100	70-029-0100	70-029-0100	70-029-0100	70-029-0100
55	Handle	70-001-0103	70-001-0103	—	—	—
56	Front Handle	—	—	70-042-0100	70-042-0200	70-042-0200
57	Rear Handle	—	—	70-043-0100	70-043-0200	70-043-0200
58	Wheel Support Frame	—	—	70-041-0101	70-041-0201	70-041-0201
59	Wheel Axle	—	—	70-041-0103	70-041-0203	70-041-0203
60	Wheel (Pneumatic)	—	—	70-041-0150	70-041-0150	70-041-0150
61	Wheel Cap	—	—	70-041-0104	70-041-0104	70-041-0104
62	Hardware Kit	70-056-0100	70-056-0100	70-056-0200	70-056-0200	70-056-0200
63	Cord Wrap	70-032-0100	70-032-0100	70-032-0200	70-032-0200	70-032-0200

**NEVER LEAVE HEATER
UNATTENDED WHILE BURN-
ING OR WHILE CONNECTED
TO A POWER SOURCE**

MASTER®

**Kerosene
Forced Air Heaters**

Wiring Diagrams

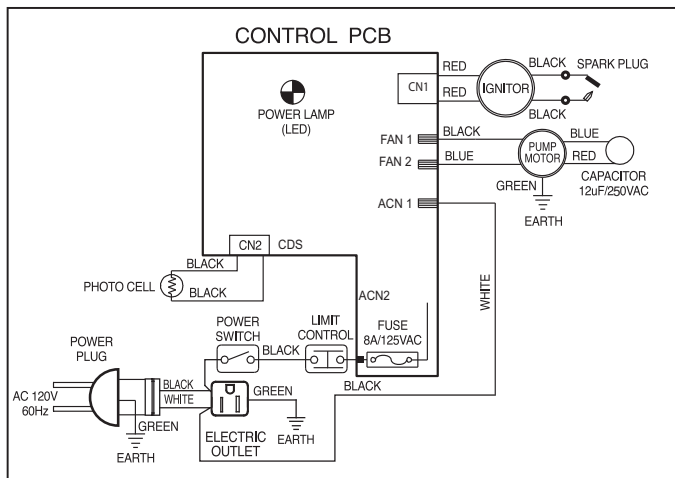

Figure 22 Model MH-45-KFA

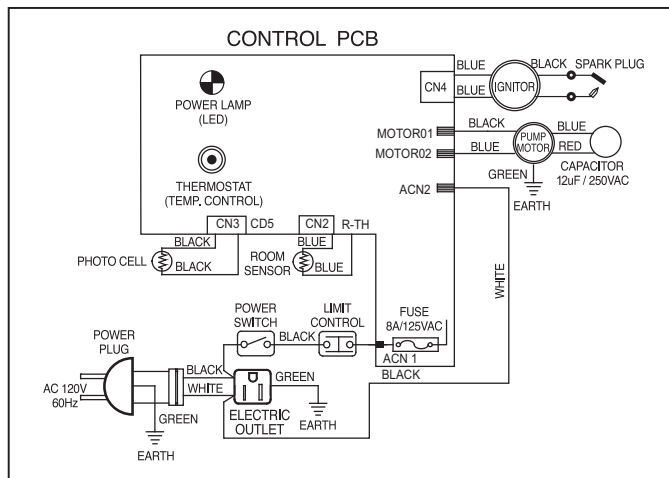

Figure 23 Model MH-70T-KFA

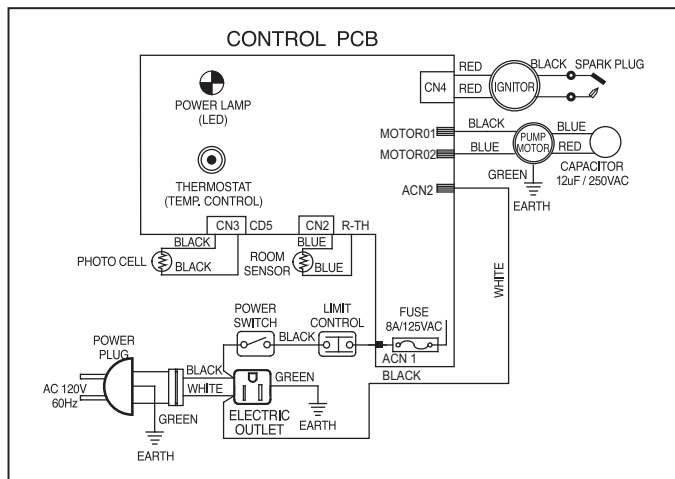

Figure 24 Model MH-125T/ 175T/ 215T-KFA

Troubleshooting Guide

Problem	Possible Cause	Solution
Heater fires, but Main PCB shuts heater off after a short period of time. Lamp is flickering, and LED display shows "E1".	<ol style="list-style-type: none"> 1. Incorrect pump pressure 2. Dirty Input, Output or Lint Filter 3. Dirty Fuel Filter 4. Nozzle is Dirty 5. Photocell lens is Dirty 6. Photocell not installed properly 7. Photocell Defective 8. Improper electrical connection between Main PCB and Photocell. 	<ol style="list-style-type: none"> 1. Adjust Pump Pressure (Page 11) 2. Clean/replace Air Filter (Page 9) 3. Clean/replace Fuel Filter (Page 10) 4. Clean/replace Nozzle (Page 9) 5. Clean/replace Photocell (Page 10) 6. Adjust Photocell position (Page 10) 7. Replace Photocell (Page 10) 8. Check wiring connections (See Wiring Diagrams, Page 14)
Heater will not operate, or motor runs for short time. Lamp flickers and LED display shows "E1".	<ol style="list-style-type: none"> 1. No kerosene in fuel tank 2. Incorrect pump pressure 3. Corroded Spark Plug or incorrect plug gap. 4. Dirty Fuel Filter 5. Dirty Nozzle 6. Moisture in Fuel/Fuel Tank 7. Improper electrical connection between Transformer and Circuit Board 8. Ignitor Wire not connected to Spark Plug 9. Defective Ignitor 	<ol style="list-style-type: none"> 1. Fill tank with fresh kerosene 2. Adjust Pump Pressure (Page 11) 3. Clean/replace Spark Plug (Page 10) 4. Clean/replace Fuel Filter (Page 10) 5. Clean/replace Nozzle (Page 9) 6. Rinse out fuel tank with clean fresh kerosene (Page 9) 7. Inspect all electrical connections. See Wiring Diagrams (Page 14) 8. Re-attach Ignitor wire to Spark Plug (Page 9) 9. Replace Ignitor
Fan does not operate when heater is plugged in and Power Switch is in the "ON" position. The lamp is flickering or on and LED Display shows "E1" or "E2".	<ol style="list-style-type: none"> 1. Thermostat is set too low (Does not apply to PT-45-KFA) 2. Broken electrical connection between Main PCB and motor 	<ol style="list-style-type: none"> 1. Rotate thermostat to a higher setting 2. Inspect all electrical connections. See Wiring Diagrams (Page 14)
Lamp is flickering, and LED display shows "E3"	<ol style="list-style-type: none"> 1. Thermostat Switch has failed 	<ol style="list-style-type: none"> 1. Replace Thermostat Switch. Wiring Diagrams (Page 14)
Poor Combustion and / or excess soot production	<ol style="list-style-type: none"> 1. Dirty Input, Output or Lint Filter 2. Dirty Fuel Filter 3. Poor quality of fuel 4. PSI is too high or too low 	<ol style="list-style-type: none"> 1. Clean/replace Air Filter (Page 9) 2. Clean/replace Fuel Filter (Page 10) 3. Be sure fuel is not contaminated or old 4. Use proper pressure (Page 11)
Heater does not turn on and the lamp is not lit	<ol style="list-style-type: none"> 1. Temperature limit sensor has overheated 2. No electrical power 3. Fuse Blown 4. Improper electrical connection between Temperature Limit Sensor and Circuit Board 	<ol style="list-style-type: none"> 1. Push Power Switch to "OFF" and allow heater to cool for 10 minutes. Push Power Switch to back to "ON" 2. Check power cord and extension cord to insure of proper connection. Test power supply 3. Check/replace Fuse 4. Inspect all electrical connections. Wiring Diagrams (Page 14)

NEVER LEAVE HEATER
UNATTENDED WHILE BURN-
ING OR WHILE CONNECTED
TO A POWER SOURCE

MASTER®

Kerosene
Forced Air Heaters

LIMITED WARRANTY

Pinnacle Products International, Inc. warrants this heater to the original retail purchaser only, to be free from defects in material and workmanship for a period of one (1) year from the date of initial purchase. This product must be properly installed, maintained and operated in accordance with the instructions provided.

Pinnacle Products International, Inc. requires reasonable proof of your date of purchase from an authorized retailer or distributor. Therefore, you should keep your sales slip, invoice, or cancelled check from the original purchase. This Limited Warranty shall be limited to the repair or replacement of parts, which prove defective under normal use and service within the warranty period, and which **Pinnacle Products International, Inc.** shall determine at its reasonable discretion.

This warranty does not apply to products purchased for rental use.

This Limited Warranty does not cover any failures or operating difficulties due to normal wear and tear, accident, abuse, misuse, alteration, misapplication, improper installation or improper maintenance and service by you or any third party. Failure to perform normal and routine maintenance on the heater, shipping damage, damage related to insects, birds, or animals of any kind, and damage due to weather conditions are also not covered. In addition, the Limited Warranty does not cover damage to the finish, such as scratches, dents, discoloration, rust or other weather damage, after purchase.

All transportation costs for the return of the damaged product or parts will be the responsibility of the purchaser. Upon receipt of damaged item, **Pinnacle Products International, Inc.** will examine the item and determine if defective. **Pinnacle Products International, Inc.** will repair or replace and return the item, freight pre-paid. If **Pinnacle Products International, Inc.** finds the item to be in normal operating condition, or not defective, the item will be returned freight collect. This Limited Warranty is in lieu of all other express warranties. **Pinnacle Products International, Inc.** disclaims all warranties for products that are purchased from sellers other than authorized retailers or distributors.

AFTER THE PERIOD OF THE ONE (1) YEAR EXPRESS WARRANTY EXPIRES, **Pinnacle Products International, Inc.** DISCLAIMS ANY AND ALL IMPLIED WARRANTIES, INCLUDING WITHOUT LIMITATION THE IMPLIED WARRANTIES OF MERCHANTABILITY AND FITNESS FOR A PARTICULAR APPLICATION. FURTHER, **Pinnacle Products International, Inc.** SHALL HAVE NO LIABILITY WHATSOEVER TO PURCHASER OR ANY THIRD PARTY FOR ANY SPECIAL, INDIRECT, PUNITIVE, INCIDENTAL, OR CONSEQUENTIAL DAMAGES. **Pinnacle Products International, Inc.** assumes no responsibility for any defects caused by third parties. This Limited Warranty gives the purchaser specific legal rights; a purchaser may have other rights depending upon where he or she lives. Some states do not allow the exclusion or limitation of special, incidental or consequential damages, or limitations on how long a warranty lasts, so the above exclusion and limitations may not apply to you.

Pinnacle Products International, Inc. does not authorize any person or company to assume for it any other obligation or liability in connection with the sale, installation, use, removal, return, or replacement of its equipment, and no such representations are binding on **Pinnacle Products International, Inc.**

Always be sure to specify model number and serial number when making any claim with **Pinnacle Products International, Inc.** For your convenience use the space provided below to list this information:

Model #: _____

Serial #: _____

Date of Purchase: _____