

REVISIONS				
REV.	DESCRIPTION	ECN#	APPROVED	DATE
A	NEW RELEASE	DC16-0005	Don H.	1/6/2016

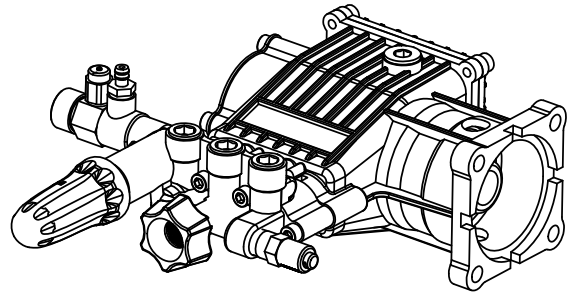

530008, 530009 PUMP SERVICE DRAWING

PUMPS	
PART NO.	MODEL
530008	8.7GA12
530009	9.6GA12

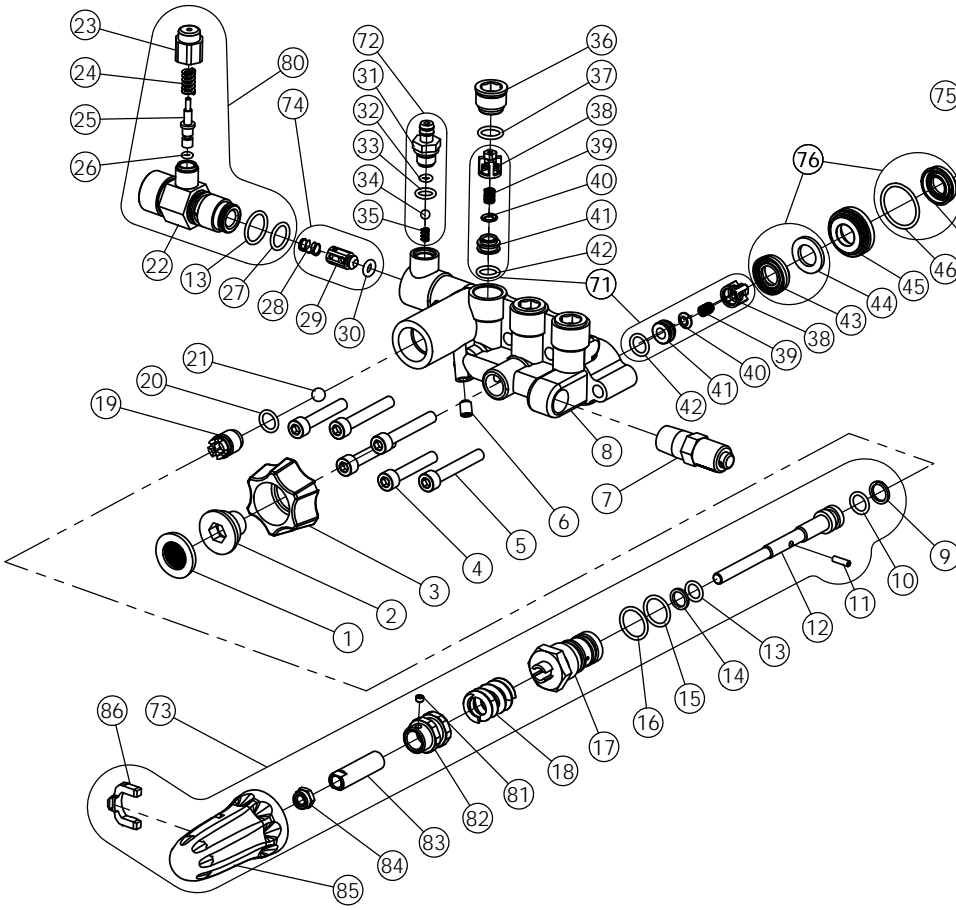
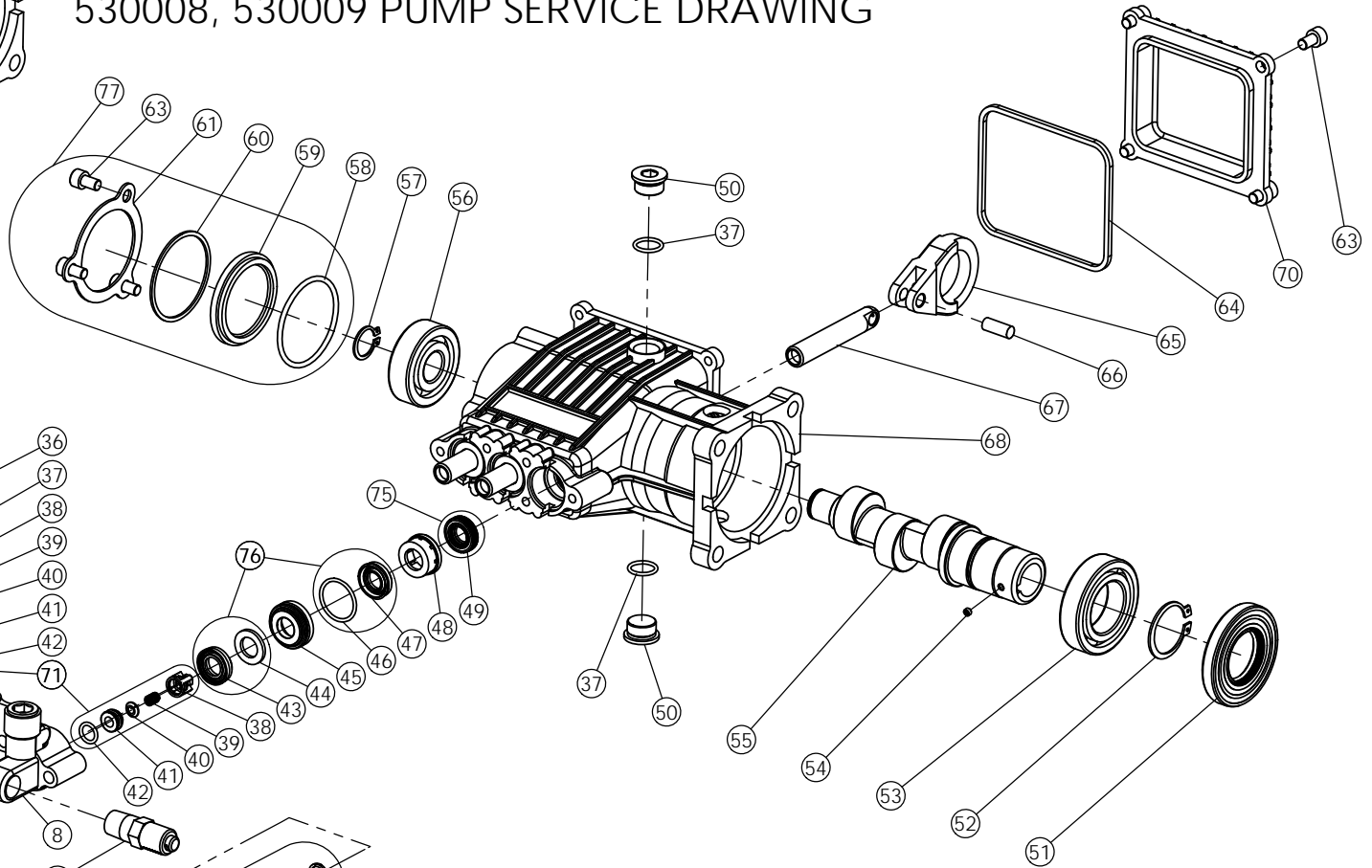

TORQUE SPECIFICATIONS			
ITEM	FT-LB	IN-LB	N-M
2	13	155	18
4	9	100	11
5	8	100	11
6	3	35	4
8	13	155	18
17	13	155	18
22	13	155	18
23	13	155	18
31	9	110	13
36	13	155	18
50	13	155	18
63	7	80	9

	NAME	DATE
DRAWN	KDB	12/29/2015
CHECKED	-	-
ENG APPR.	-	-
MFG APPR.	-	-
Q.A. APPR.	-	-
SERVICE APPR.	-	-

PROPRIETARY AND CONFIDENTIAL
 THE INFORMATION CONTAINED IN THIS DRAWING IS THE SOLE PROPERTY OF FNA-GROUP. ANY REPRODUCTION IN PART OR AS A WHOLE WITHOUT THE WRITTEN PERMISSION OF FNA-GROUP IS PROHIBITED.

FNA-GROUP
 1265 INDUSTRIAL STREET, DECATUR, AR 72722

TITLE:
C31 SERIES PUMP, 3400PSI @ 2.3 GPM/3200 @ 2.5 GPM, HORIZ

SIZE	DWG. NO.	REV.
A	530008, 530009	A

SCALE: N/A ECN# DC16-0005 SHEET 1 OF 5

530008, 530009 PARTS LIST

ITEM	PART NO.	DESCRIPTION	QTY
1	7000123	SCREEN, WATER INLET	1
2	7105704	CONNECTOR, WATER INLET	1
3	7105705	NUT, HAND TIGHT	1
4	7000325	SCREW, M6-1.0 X 35 GR 8.8	3
5	7105436	SCREW, M6-1.0 X 40 GR 8.8	3
6	7104692	SCREW, SET M6-1.0 X 8	1
7	7101359	VALVE, THERMAL RELIEF	1
8	7105706	MANIFOLD	1
9	N/A	BACK UP RING	1
10	N/A	O-RING, 9X1.8	1
11	N/A	LOCK PIN	1
12	N/A	STEM ASSY	1
13	N/A	O-RING, 8X1.8	1
14	N/A	BACK UP RING	1
15	N/A	O-RING, 14X1.8	1
16	N/A	O-RING, 15X1.8	1
17	N/A	UNLOADER VALVE	1
18	N/A	UNLOADER SPRING	1
19	7105708	VALVE SEAT	1
20	7105709	O-RING, 9X1.8	1
21	7105710	BALL, UNLOADER VALVE	1
22	7105711	BODY, SOAP INJECTOR	1
23	7105712	CAP, BOOST VALVE	1
24	7105713	SPRING, BOOST VALVE	1
25	7105714	VALVE, PRESSURE BOOST	1
26	7105715	O-RING, 2.5X1.8	1
27	7105716	O-RING, 11.8x1.8	1
28	N/A	SPRING, CHECK VALVE	1
29	N/A	CHECK VALVE	1
30	N/A	O-RING, 4.5X2.65	1
31	N/A	FITTING, SOAP INJECTION	1
32	N/A	O-RING, 7.5X1.8	1
33	N/A	O-RING, 3.5X 1.8	1
34	N/A	BALL, 3/16" SOAP VALVE	1
35	N/A	SPRING, SOAP VALVE	1
36	7105717	PLUG, MANIFOLD	3
37	7105718	O-RING, 13X1.8	5
38	N/A	CAGE, VALVE	6
39	N/A	SPRING, VALVE	6
40	N/A	DISK, VALVE	6
41	N/A	SEAT, VALVE	6
42	N/A	O-RING, 9X1.8	6
43	N/A	SEAL, HIGH PRESSURE	3
44	N/A	RING, ANTI-EXT	3
45	7105719	RETAINER	3
46	N/A	O-RING, 22X1.8	3
47	N/A	SEAL, LOW PRESSURE	3
48	7105720	RETAINER, SEAL	3
49	N/A	SEAL, OIL	3

530008, 530009 PARTS LIST

ITEM	PART NO.	DESCRIPTION	QTY
50	7105721	PLUG, CRANKCASE	2
51	7105722	SEAL, OIL 29.5X58X8	1
52	7105723	RING, M30 RETAINING	1
53	7105724	BEARING, CRANKSHAFT 6006	1
54	7103426	SCREW, M4-0.7 X 4	1
55	-	CRANKSHAFT	-
-	7105725	CRANKSHAFT 8.7GA12	1
-	7105726	CRANKSHAFT 9.6GA12	1
56	7105727	BEARING, CRANKSHAFT 6303	1
57	7105729	RING, M17 RETAINING	1
58	N/A	O-RING, 47.5X2.65	1
59	N/A	INTERNAL RETAINING RING, SELF LOCKING	1
60	N/A	SIGHT GLASS	1
61	N/A	BACK-UP RING	1
63	7103437	SCREW, M6x10	7
64	7105728	O-RING, 90X3.5	1
65	7105730	CONNECTING ROD	3
66	7105731	PIN, CONNECTING ROD	3
67	7105732	PISTON, CERAMIC COATED	3
68	7105733	CRANKCASE, HOUSING BLACK	1
70	7105737	CRANKCASE END COVER, BLACK	1
81	N/A	SET SCREW	1
82	N/A	ADJUST	1
83	N/A	NUT M6	1
84	N/A	HEX NUT	1
85	N/A	UNLOADER CAP	1
86	N/A	CAP LOCKER	1

530008, 530009 KITS

ITEM	PART NO.	DESCRIPTION	QTY
71	7104223	VALVE KIT	6
72	7104228	SOAP INJECTOR KIT	1
73	7108745	UNLOADER KIT	1
74	7105740	UNLOADER CHECK VALVE KIT	1
75	7105741	OIL SEAL KIT	1
76	7105742	HIGH AND LOW PRESSURE SEAL KIT	1
77	7105921	CRANKCASE SIDE COVER KIT	1
78	7108746	MANIFOLD KIT	1
79	-	CRANKCASE KIT	-
-	7105936	CRANKCASE KIT, 8.7GA12 BLACK	1
-	7105937	CRANKCASE KIT, 9.6GA12 BLACK	1
80	7106264	OUTLET FITTING KIT	1

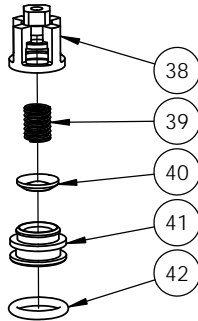

71 **PART NO. 7104223**
VALVE KIT

ITEM	QTY	DESCRIPTION
38	6	CAGE, VALVE
39	6	SPRING, VALVE
40	6	DISK, VALVE
41	6	SEAT, VALVE
42	6	O-RING

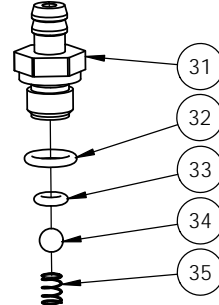

72 **PART NO. 7104228**
SOAP INJECTOR KIT

ITEM	QTY	DESCRIPTION
31	1	FITTING, SOAP INJECTOR
32	1	O-RING
33	1	O-RING
34	1	BALL, 3/16" SOAP VALVE
35	1	SPRING, SOAP VALVE

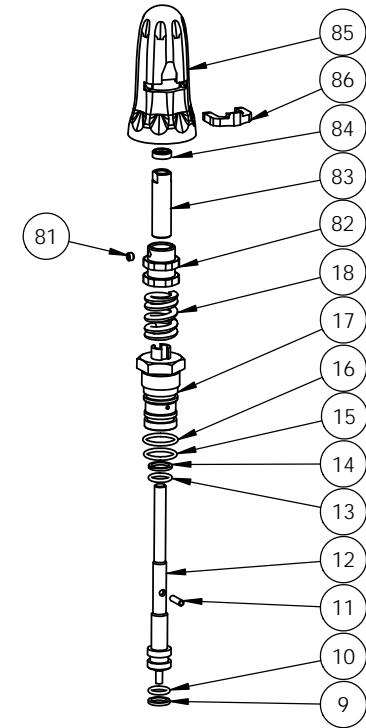

73 **PART NO. 7108745**
UNLOADER KIT

ITEM	QTY	DESCRIPTION
9	1	BACK UP RING
10	1	O-RING, 9X1.8
11	1	LOCK PIN
12	1	STEM ASSY
13	1	O-RING, 8X1.8
14	1	BACK UP RING
15	1	O-RING, 14X1.8
16	1	O-RING, 15X1.8
17	1	UNLOADER VALVE
18	1	UNLOADER SPRING
81	1	SET SCREW
82	1	ADJUST
83	1	NUT M6
84	1	HEX NUT
85	1	UNLOADER CAP
86	1	CAP LOCKER

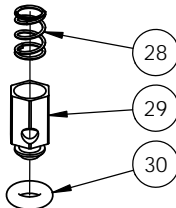

74 **PART NO. 7105740**
UNLOADER CHECK VALVE KIT

ITEM	QTY	DESCRIPTION
28	1	SPRING, CHECK VALVE
29	1	CHECK VALVE
30	1	O-RING

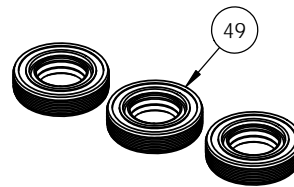

75 **PART NO. 7105741**
OIL SEAL KIT

ITEM	QTY	DESCRIPTION
49	3	SEAL, OIL

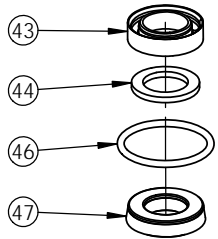

PART NO. 7105742

76 HIGH AND LOW PRESSURE SEAL KIT

ITEM	QTY	DESCRIPTION
43	3	SEAL, HIGH PRESSURE
44	3	RING, ANTI-EXT
46	3	O-RING
47	3	SEAL, LOW PRESSURE

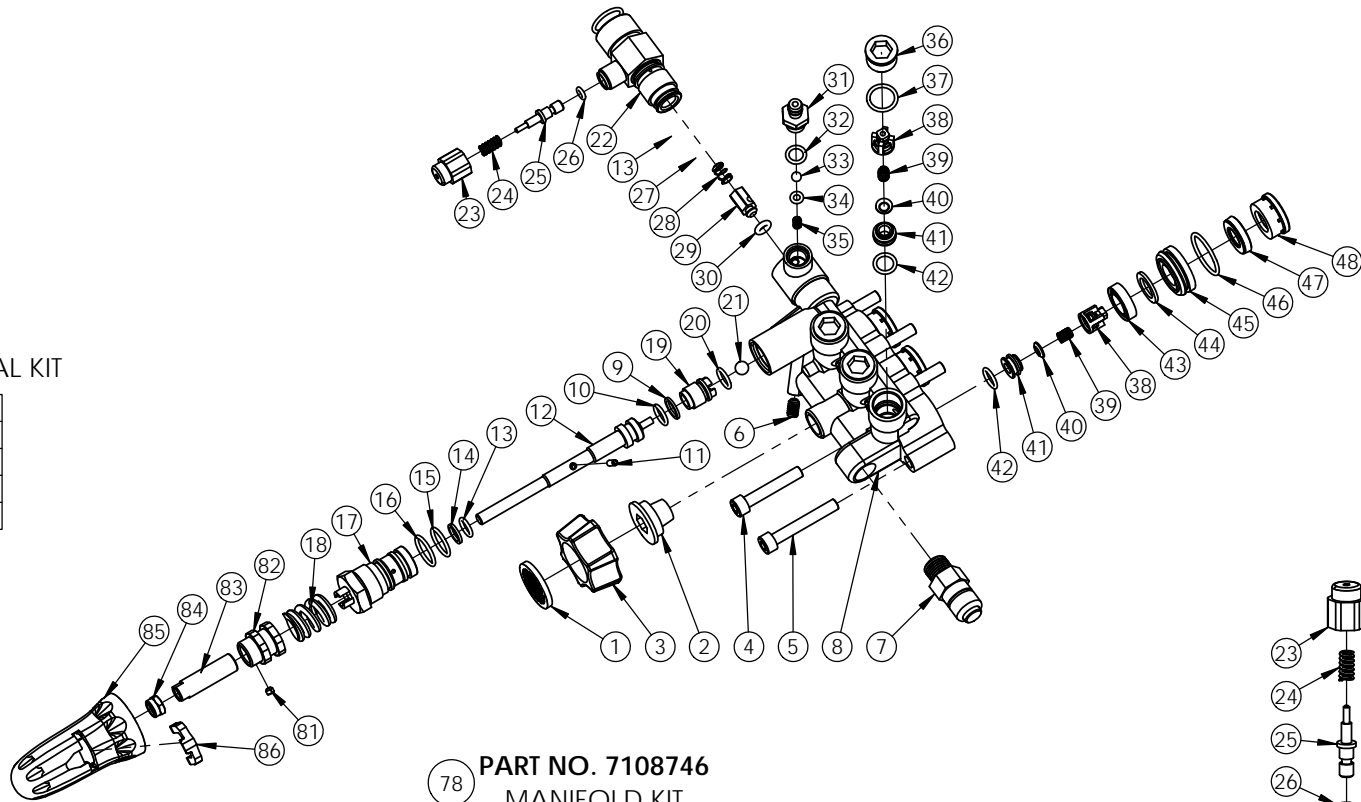

**78 PART NO. 7108746
MANIFOLD KIT**

ITEM	QTY	DESCRIPTION
1	1	SCREEN, WATER INLET
2	1	CONNECTOR, WATER INLET
3	1	NUT, HAND TIGHT
4	3	SCREW
5	3	SCREW
6	1	SCREW, SET
7	1	VALVE, THERMAL RELIEF
8	1	MANIFOLD
9	1	NUT, UNLOADER JAM
10	1	NUT, UNLOADER ADJUSTMENT
11	1	SPRING, UNLOADER
12	1	GUIDE BUSHING, UNLOADER
13	2	O-RING
14	1	BACK-UP RING, UNLOADER VALVE
15	1	O-RING
16	1	STEM, UNLOADER
17	1	O-RING
18	1	BACK-UP RING, SPLIT
19	1	VALVE SEAT
20	1	O-RING
21	1	BALL, UNLOADER VALVE
22	1	BODY, SOAP INJECTOR
23	1	CAP, BOOST VALVE
24	1	SPRING, BOOST VALVE

ITEM	QTY	DESCRIPTION
25	1	VALVE, PRESSURE BOOST
26	1	O-RING
27	1	O-RING
28	1	SPRING, CHECK VALVE
29	1	CHECK VALVE
30	1	O-RING
31	1	FITTING, SOAP INJECTION
32	1	O-RING
33	1	O-RING
34	1	BALL, 3/16" SOAP VALVE
35	1	SPRING, SOAP VALVE
36	3	PLUG, MANIFOLD
37	3	O-RING
38	6	CAGE, VALVE
39	6	SPRING, VALVE
40	6	DISK, VALVE
41	6	SEAT, VALVE
42	6	O-RING
43	3	SEAL, HIGH PRESSURE
44	3	RING, ANTI-EXT
45	3	RETAINER
46	3	O-RING
47	3	SEAL, LOW PRESSURE
48	3	RETAINER, SEAL

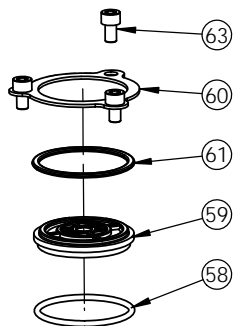

PART NO. 7105921

77 CRANKCASE END COVER KIT

ITEM	QTY	DESCRIPTION
58	1	O-RING
59	1	SIGHT GLASS
60	1	CRANKCASE, SIDE COVER
63	3	SCREW

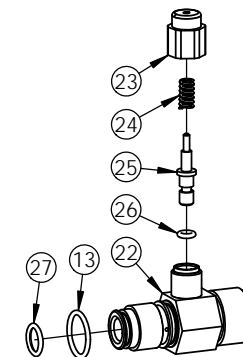

**80 PART NO. 7106264
OUTLET FITTING KIT**

ITEM	QTY	DESCRIPTION
23	1	CAP, BOOST VALVE
24	1	SPRING, POWER BOOST VALVE
25	1	VALVE, PRESSURE BOOST
26	1	O-RING
22	1	BODY, SOAP INJECTOR
13	1	O-RING
27	1	O-RING

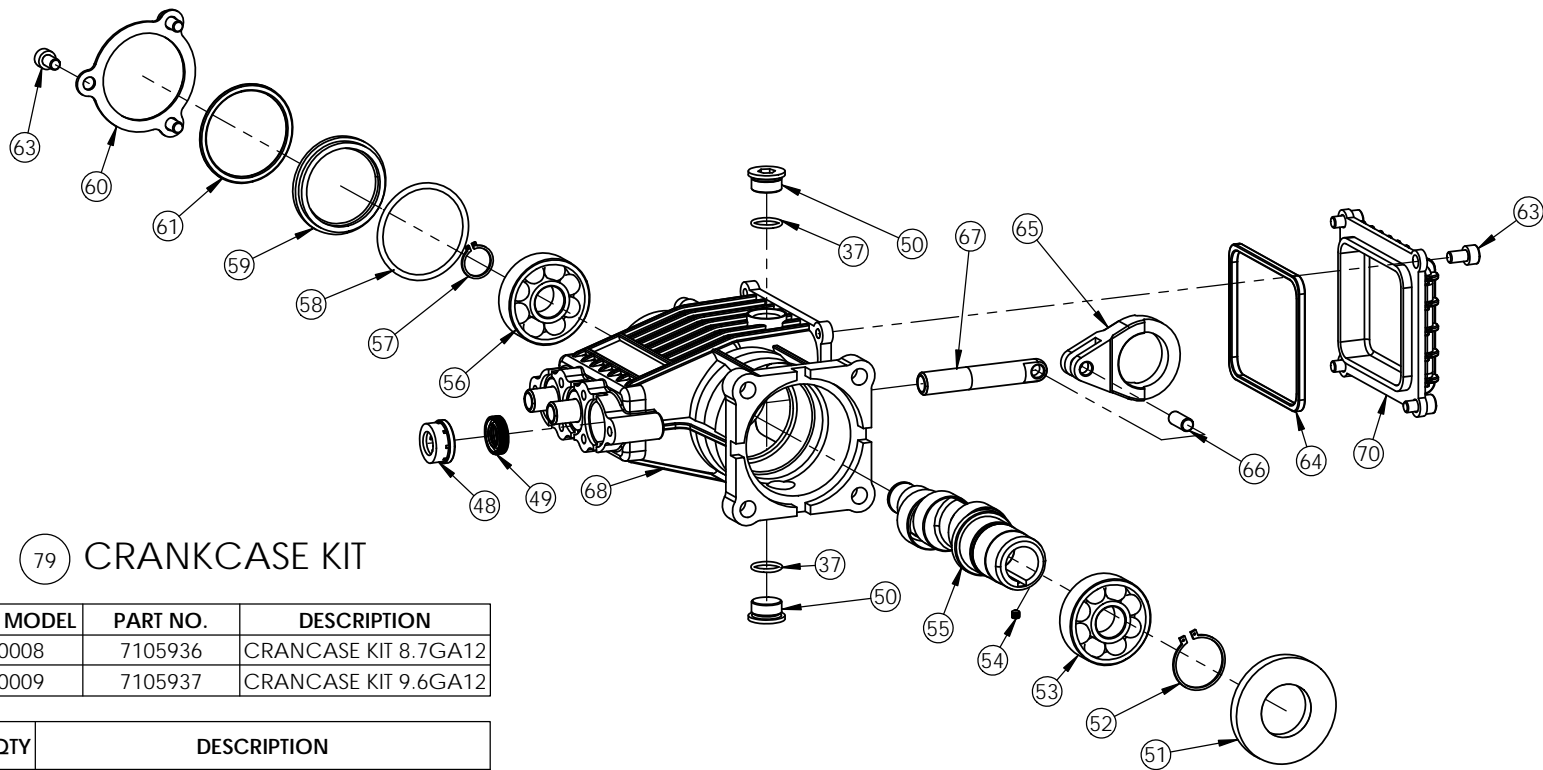

79 CRANKCASE KIT

PUMP MODEL	PART NO.	DESCRIPTION
530008	7105936	CRANKCASE KIT 8.7GA12
530009	7105937	CRANKCASE KIT 9.6GA12

ITEM	QTY	DESCRIPTION
37	2	O-RING
48	3	RETAINER, SEAL
49	3	SEAL, OIL
50	2	PLUG, CRANKCASE
51	1	SEAL, OIL
52	1	RING, RETAINING
53	1	BEARING, CRANKCASE
54	1	SCREW
55	-	CRANKSHAFT
-	1	CRANKSHAFT 8.7GA12
-	1	CRANKSHAFT 8.7GA12
56	1	BEARING, CRANKSHAFT
57	1	RING, RETAINING
58	1	O-RING
59	1	SIGHT GLASS
60	1	CRANKCASE SIDE COVER
61	1	RETAINGING RING
63	7	O-RING
64	1	GASKET
65	3	CONNECTING ROD
66	3	PIN, CONNECTING ROD
67	3	PISTON, CERAMIC COATED
68	1	CRANKCASE, HOUSING BLACK
70	1	CRANKCASE, END COVER