



The Item Numbers in the Chart(s) below refer to the Pump Breakdown on Page 2.

Item:	Part Number	Qty	Description
1	SS-29	6	3/8-16 x 2" HHCS
2	33382-112	2	Intake Valve Plug
3	44185-027	2	Intake Valve Assembly
4	356-9403	1	Intake Filter Assembly
5	357-9701	1	Intake Filter Element
6	SS-2037	1	1/4" Wing Nut
7	31438-124	1	Flywheel
8	32233-122	1	Flywheel Washer
9	SS-3607-CD	1	3/8" Medium Lockwasher
10	SS-25-CD	1	3/8-16 x 1" HHCS
11	SS-912	4	10-24 X 3/8" RHMS
12	33465-120	1	End Plate
13	38251-122	1	End Plate Gasket
14	130-111	1	Oil Seal
15	330-160	1	Washer
16	220-6	1	Oil Throw Ring Retainer
17	NCB-303-1	1	Oil Filler Plug
18	SS-2670	1	'O' Ring
19	33351-115	2	Exhaust Valve Cap
20	SS-2525	2	Gasket
21	33654-113	2	Exhaust Valve Retainer
22	44185-026	2	Exhaust Valve Assembly

Item:	Part Number	Qty	Description
23	37132-120	1	Cylinder Head
24	38547-108	1	Head Gasket
25	KK-9848	2	Ring Kit (Std.)
26	45855-131	2	Piston & Pin Assembly (Std.)
27	SS-3673	2	1/4" Shakeproof Lockwasher
28	SS-5	2	Screw
29	SS-3674	2	5/16" Shakeproof Lockwasher
30	21741-193	4	Screw
31	45856-170	2	Rod & Cap Assembly
32	37136-111	1	Cylinder & Crankcase
33	SS-1	6	1/4-20 x 1/2" HHCS
34	36883-105	1	Inspection Plate
35	38513-125	1	Inspection Plate Gasket
36	130-23	2	Ball Bearing
37	SS-1228	1	1/4" Oil Drain Plug
38	SS-1578	1	3/16" x 1" Key number 13
39	225-43	2	Oil Cup
40	45817-526	1	Crankshaft/Oil Cup Assembly
41	32541-115	2	Oil Throw Ring
42	38281-110	1	End Plate Gasket
43	37331-106	1	End Plate
44	SS-12	4	5/16-18 x 3/4" HHCS

Note: Item # 3 ('44185-027') and # 22 ('44185-026') have been labelled as 'Intake' and 'Exhaust' in the past. Recent Valves are similar, with only the orientation in the Head being different.

Kits Available for the '44633' Pump

Part Number	Qty	Description	Includes
45875-026	1	Complete Gasket Kit	# 13, 18, 20, 24, 35, 42, and CPR End Plate Gasket
VK-633	1	Valve Kit	# 3, 20, 22
OK-633	1	Overhaul Kit	# 14, 25, and (1) '45875-026', (1) 'VK-633'



Centrifugal Pressure Release Assembly

Old Style 'CPR' Assembly.

Please note that items marked 'NLA' are 'no longer available'.

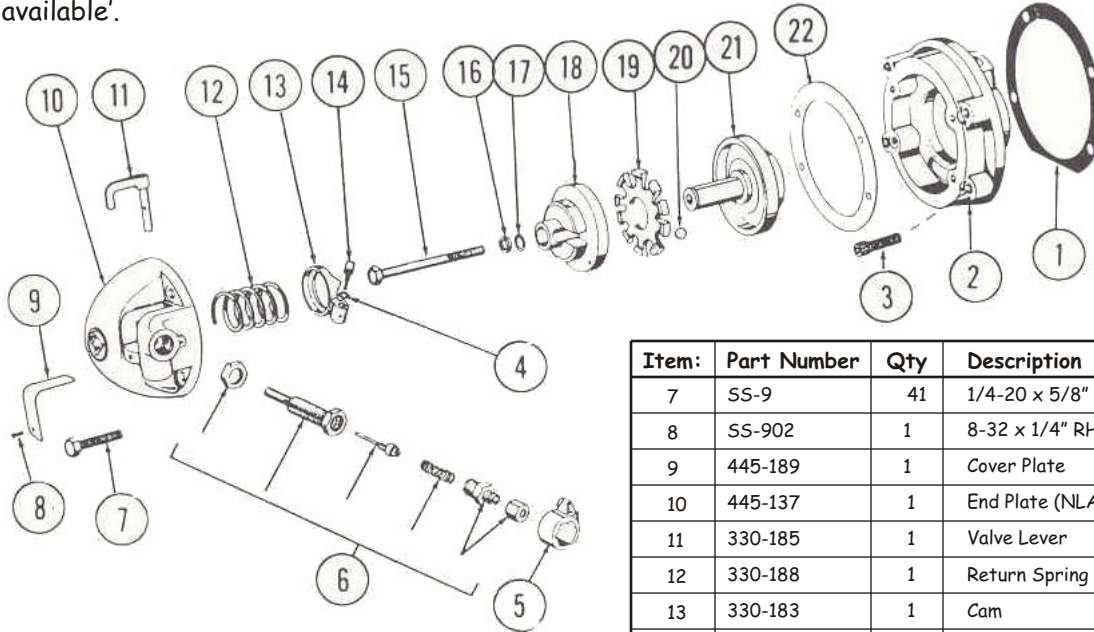

Item:	Part Number	Qty	Description
1	38281-110	1	End Plate Gasket
2	37335-105	1	Press. Release Housing (NLA)
3	SS-7840	4	5/16-18 x 1-1/4" HHCS
4	SS-3672	1	Lock Washer 3/16"
5	330-153-1	1	Seal Cap (No Longer Required)
6	330-430-3	1	CPR Valve Assembly

Item:	Part Number	Qty	Description
7	SS-9	41	1/4-20 x 5/8" HHCS
8	SS-902	1	8-32 x 1/4" RHMS
9	445-189	1	Cover Plate
10	445-137	1	End Plate (NLA)
11	330-185	1	Valve Lever
12	330-188	1	Return Spring
13	330-183	1	Cam
14	330-184	1	Screw (NLA)
15	SS-6914	1	5/16-18 x 2-3/4" HHCS
16	SS-1503	1	Med. Lock Washer 5/16"
17	330-182	1	Snap Ring
18	330-419-1	1	Ball Cam Assy (NLA)
19	330-139-1	1	Ball Cage (NLA)
20	SS-1555	1	5/16" Dia. Hard Steel Ball
21	330-433	1	Ball Cup Assy (NLA)
22	445-144	1	End Plate Gasket

Note: This Kit can only be used on Pumps that operate at 500 rpm or more.

New Style 'CPR' Assembly.

This CPR can be retro-fitted onto an existing '44633' Series Pump. Order:

- (1) 'CPR-9700' Kit
- (4) 'SS-7840' HHCS
- (1) '37335-106' CPR Housing
- (1) '38281-110' Gasket

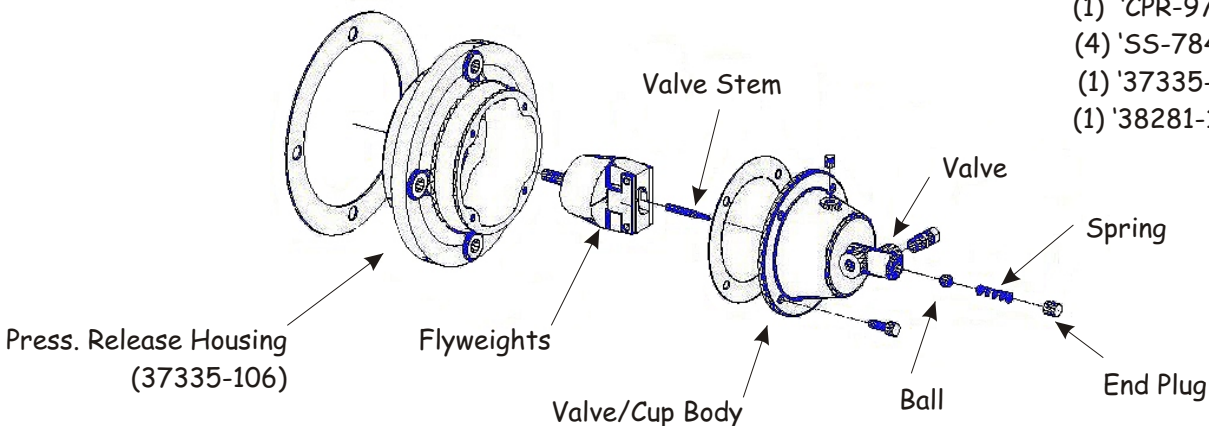



Compressor Torque Values

Item:	Description	In Lbs	Ft Lbs	Nm
1	Head Bolts	240	20	27.1
2	Valve Plug	180	15	20.3
3	CPR Housing (See Page 4)	144	12	16.2
7	CPR End Plate (See Page 4)	72	6	8.1
10	Flywheel Bolt	360	30	40.6
10	Ball Cam Assy (See Page 4)	144	12	16.2
16	Oil Retainer Ring	144	12	16.2
19	Valve Cap	125	10.5	14.2
28	Connecting Rod - Pin End	90	7.5	10.1
30	Connecting Rod - Crank End	228	19	25.7
33	Inspection Cover	72	6	8.1
44	Large End Plate	144	12	16.2

Honing Specifications

	Std. Cylinder Hone Diameter	Piston Skirt/ Cyl Dia Clear.
Low Pressure Cylinder	2.5000	.0035
	2.5005	.0055

1. Diametral Clearance of oversized Cylinders and Pistons is the same as standard Cylinders and Pistons.
2. Cylinders must be within diametral tolerance at all points, out of round or taper must not exceed .0005.
3. Hone 20 min to 35 max micro inches of surface roughness.
4. De-burr the sharp corners at the top of the Cylinder opening with a 1/64 to 1/32 x 30° chamfer.

'44633' Pump Specifications

Pump Model	HP	150 psi		100 psi		# of Cyl.	Bore	Stroke	Flywheel		Pump Dimensions (Refer to drawing)						Weight (Pounds) (Approx)
		RPM	Del'y (CFM)	RPM	Del'y (CFM)				Dia.	Groove	A	B	C	D	E	F	
44633	1	350	2.4	450	3.7	2	2.5"	2.25"	12"	1A	9"	14.125"	15.625"	13"	6.5"	6.5"	70
	1½	630	4.44	710	5.6												
	2	930	6.32	1000	7.7												

Note: Though the dimensions are correct, the Pump may not be exactly as shown.

