

**OWNERS MANUAL**  
**FORCED AIR PROPANE CONSTRUCTION HEATERS**  
Models  
30-FAS/SPC-30, 55-F/SPC-55, 85-FAC/SPC-85, 125-F/SPC-125



**QUESTIONS?**  
**MISSING / DAMAGED PARTS**

**Please do not return this product to the store.**  
If a part is damaged or missing, simply e-mail us at [php@allpro-heaters.com](mailto:php@allpro-heaters.com), or visit our website at <http://allpro-heaters.com>, or call our Customer Service Department at (888) 619-7060. We will be happy to assist you!  
You can register your heater on line at <http://allpro-heaters.com/warranty>.

**TABLE OF CONTENTS**

HEATER SPECIFICATIONS.....	2
 WARNINGS .....	2
OPERATING PRECAUTIONS .....	3
SAFETY PRECAUTIONS .....	3
ODOR FADE WARNING .....	4
OPERATING INSTRUCTIONS .....	5
SERVICING .....	5
SIZE AND CAPACITY OF PROPANE CYLINDERS REQUIRED.....	6
WIRING DIAGRAMS. ....	7
30-FAS / SPC-30 - PARTS.....	8
55-F / SPC-55 - PARTS .....	9
85-FAC / SPC-85 - PARTS .....	10
125-F / SPC-125 - PARTS .....	11
WARRANTY.....	12
SERVICE CENTERS .....	12
INSTRUCTIONS FOR ORDERING PARTS .....	12
WARRANTY REGISTRATION .....	13

**RETAIN THESE INSTRUCTIONS FOR FUTURE REFERENCE**

# Models

## 30-FAS/SPC-30, 55-F/SPC-55, 85-FAC/SPC-85, 125-F/SPC-125

### HEATER SPECIFICATIONS

Type of Gas:	For use with Propane Only			
Gas Supply Pressure to regulator regulator out	Maximum: Bottle Pressure 28" W.C. (6.97 kPa) (11" W.C. (2.74 kPa) for 30-FAS/SPC-30		Minimum: 5 psig (34.5 kPa)	
Electrical Input:	115V, 60 Hz, 1Ø, 3a		Minimum Operating Voltage: 100V	
Ignition:	Direct Spark (manually operated for 30-FAS/SPC-30 heaters)			
Primary Flame Control:	Thermocouple Operated Gas Valve			
High Temperature Control:	240°F (116°C)		Minimum Ambient Temp. Rating	0°F (-17.8°C)
<b>Model:</b>	<b>30-FAS / SPC-30</b>	<b>55-F/SPC-55</b>	<b>85-FAC / SPC-85</b>	<b>125-F / SPC-125</b>
Rating:	30,000 Btu/hr	30,000-55,000 Btu/hr	50,000 – 85,000 Btu/hr	75,000 – 125,000 Btu/hr
	(8.8 KW)	(8.8-16.1 kw)	(14.6 – 25.0 kW)	(21.9 – 36.6 kW)
Fuel Consumption:	1.4 lbs/hr	1.4-2.5 lbs/hr	2.3 – 3.9 lbs/hr	3.5 – 5.8 lbs/hr
	(.64 kg/hr)	(.64-1.1 kg/hr)	(1.04 – 1.77 kg/hr)	(1.59 – 2.63 kg/hr)
Fuel Orifice Port No.:	1	18	18	18
Fuel Orifice Port Size:	0.0730"	0.0196"	0.0240"	0.0295"
	(1.854mm)	(0.50mm)	(0.6024mm)	(0.75mm)
Heated Air Output:	140cfm	300cfm	350 cfm	350 cfm
	(3.96 cmm)	(8.49cmm)	(9.91 cmm)	(9.91 cmm)
Average Air Temp. Rise:	250°F (139°C)	200°F	200°F (111°C)	400°F (232°C)

### ⚠ WARNINGS

**YOUR SAFETY IS IMPORTANT TO YOU AND TO OTHERS, SO PLEASE READ THESE INSTRUCTIONS BEFORE YOU OPERATE THIS HEATER.**

#### ⚠ GENERAL HAZARD WARNING:

**FAILURE TO COMPLY WITH THE PRECAUTIONS AND INSTRUCTIONS PROVIDED WITH THIS HEATER, CAN RESULT IN DEATH, SERIOUS BODILY INJURY AND PROPERTY LOSS OR DAMAGE FROM HAZARDS OF FIRE, EXPLOSION, BURN, ASPHYXIATION, CARBON MONOXIDE POISONING, AND/OR ELECTRICAL SHOCK.**

**ONLY PERSONS WHO CAN UNDERSTAND AND FOLLOW THE INSTRUCTIONS SHOULD USE OR SERVICE THIS HEATER.**

**IF YOU NEED ASSISTANCE OR HEATER INFORMATION SUCH AS AN INSTRUCTIONS MANUAL, LABELS, ETC. CONTACT THE MANUFACTURER.**

#### ⚠ WARNING: NOT FOR HOME OR RECREATIONAL VEHICLE USE

**⚠ WARNING: FIRE, BURN, INHALATION, AND EXPLOSION HAZARD. KEEP SOLID COMBUSTIBLES, SUCH AS BUILDING MATERIALS, PAPER OR CARDBOARD, A SAFE DISTANCE AWAY FROM THE HEATER AS RECOMMENDED BY THE INSTRUCTIONS NEVER USE THE HEATER IN SPACES WHICH DO OR MAY CONTAIN VOLATILE OR AIRBORNE COMBUSTIBLES, OR PRODUCTS SUCH AS GASOLINE, SOLVENTS, PAINT THINNER, DUST PARTICLES OR UNKNOWN CHEMICALS.**

**Scheu Products Company, Incorporated**  
**Mail: P.O. Box 250, Upland, CA 91785**  
**Plant: 8855 Baker Ave., Rancho Cucamonga, CA 91730**  
**Telephone: 800-325-7057**  
**www.scheuco.com**  
**customerservice@scheuco.com**



ANSI Z83.7/CGA 2.14-2000

8784  
September 2003

## Models

### 30-FAS/SPC-30, 55-F/SPC-55, 85-FAC/SPC-85, 125-F/SPC-125

#### OPERATING PRECAUTIONS

This is a propane, direct-fired, forced air heater. It's intended use is primarily temporary heating of buildings under construction, alteration or repair.

Propane is heavier than air. If propane leaks from a connection or fitting, it sinks to the floor, collecting there with the surrounding air, forming a potentially explosive mixture. Obviously, propane leaks should be avoided, so set up the propane supply with utmost care. Read enclosed Odor Fade and Propane Sheet for additional information about detecting propane leaks. Leak check new connections or reconnections with a soap and water solution and follow all connection instructions herein. Also, ask your propane dealer for advice on the propane application and supply installation and ask him to check it if there are any questions.

This heater was designed and certified for use as a construction heater in accordance with ANSI Standard Z83.7/CGA 2.14-2000. Check with your local fire safety authority if you have any questions about your applications. Other standards govern the use of fuel gases and heat producing products in specific applications. Your local authority can advise you about these.

Direct-Fired means that all of the combustion products enter the heated space. Even though this heater operates very close to 100 percent combustion efficiency, it still produces small amounts of carbon monoxide. Carbon monoxide (called CO) is toxic. We can tolerate small amounts but not a lot. CO can build up in a heated space and failure to provide adequate ventilation could result in death. The symptoms of inadequate ventilation are:

headache	dizziness
burning eyes and nose	nausea
dry mouth or sore throat	

So, be sure to follow advice about ventilation in these operating instructions.

Forced Air means that a blower or fan pushes the air through the heater. Proper combustion depends upon this air flow; therefore, the heater must not be revised, modified or operated with parts removed or missing. Likewise, safety systems must not be circumvented or modified in order to operate the heater.

**When the heater is to be operated in the presence of other people the user is responsible for properly acquainting those present with the safety precautions and instructions, and of the hazards involved.**

#### SAFETY PRECAUTIONS

1. Check the heater thoroughly for damage. DO NOT operate a damaged heater.
2. DO NOT modify the heater or operate a heater which has been modified from its original condition.
3. Use only propane gas.
4. Use only VAPOR WITHDRAWAL propane supply. If there is any question about vapor withdrawal, ask your propane dealer.
5. Mount the propane cylinders vertically (shutoff valve up). Secure them from falling or being knocked over and protect them from damage.
6. Locate propane containers at least (USA) 7 ft. (2.13m), (Canada) 10 ft. (3m) from the heater and **do not** direct exhaust toward containers.
7. **IMPORTANT** Use only the hose and regulator assembly provided with the heater. Match the color stripe on the hangtag attached to the hose assembly with the color on the label located near the propane inlet fitting on the heater. Inspect hose assembly before each use of the heater. If there is excessive abrasion or wear, or hose is cut, replace with hose assembly listed on parts list before using heater.
8. For indoor use only. Area must be well ventilated. **Figure 1.** (also see "Operating Precautions").
9. If at any time gas odor is detected, IMMEDIATELY DISCONTINUE operation until the source of gas has been located and corrected. Read enclosed Odor fade and Propane Sheet for additional information about detecting propane leaks.
10. Install the heater such that it is not directly exposed to water spray, rain and/or dripping water.
11. Maintain minimum clearance from normal combustible material (like paper). **Figure 2.**
12. Due to the high surface and exhaust temperatures, adults and children must observe clearances to avoid burns or clothing ignition.
13. Operate only on a stable, level surface.
14. Do not use with duct work. Do not restrict inlet or exit.
15. Use only the electrical power specified. The electrical connection and grounding must comply with National Electrical Code - ANSI/NFPA 70 (USA) and CSA C22.1 Canadian Electrical Code, Part 1 (Canada).
16. Use only a properly grounded 3-prong receptacle or extension cord.
17. Do not move, handle or service while hot or burning.
18. Use only in accordance with local codes or, in the absence of local codes, with the Standard for the Storage and Handling of Liquefied Petroleum Gases ANSI/NFPA 58 and CSA B149.1, Natural Gas and Propane Installation Code.

**Figure 1**

VENTILATION: Minimum openings required

Heater	Opening near floor	Opening near ceiling
Infrared .....	1 ft <sup>2</sup>	1 ft <sup>2</sup>
Convection (25-VC) .....	1 ft <sup>2</sup>	1 ft <sup>2</sup>
Convection (All others) .....	2 ft <sup>2</sup>	2 ft <sup>2</sup>
Radiant .....	2 ft <sup>2</sup>	2 ft <sup>2</sup>
Forced air (30, 55) .....	1 ft <sup>2</sup>	1 ft <sup>2</sup>
Forced air (85, 125, 170F) .....	2 ft <sup>2</sup>	2 ft <sup>2</sup>
Forced air (3500-FACV, SPC-350) .....	3 ft <sup>2</sup>	3 ft <sup>2</sup>
Forced air (7000-FACV) .....	4 ft <sup>2</sup>	4 ft <sup>2</sup>

**Figure 2**

MINIMUM CLEARANCE: From normal combustible material

Clearance	Radiant		Forced Air	
	Infrared	Convection	7000-FACV	7000-FACV
From floor .....			0 ft	0 ft
From outlet .....			6 ft	10 ft
From sides .....	3 ft	4 ft	2 ft	3 ft
From top .....	6 ft		3 ft	5 ft
From front .....	6 ft			
From rear .....	2 ft			
Locate 10 ft. from canvas or plastic tarpaulins or similar coverings and secure them to prevent flapping or movement due to wind action.				

# Models

## 30-FAS/SPC-30, 55-F/SPC-55, 85-FAC/SPC-85, 125-F/SPC-125

### ODOR FADE WARNING



#### WARNING

##### Asphyxiation Hazard

- Do not use this heater for heating human living quarters.
- Do not use in unventilated areas.
- The flow of combustion and ventilation air must not be obstructed.
- Proper ventilation air must be provided to support the combustion air requirements of the heater being used.
- Refer to the specification section of the heater's manual, heater dataplate, or contact the *Scheu Products Company* to determine combustion air ventilation requirements of the heater.
- Lack of proper ventilation air will lead to improper combustion.
- Improper combustion can lead to carbon monoxide poisoning leading to serious injury or death. Symptom of carbon monoxide poisoning can include headaches, dizziness and difficulty in breathing.

#### FUEL GAS ODOR

**LP gas and natural gas have man-made odorants added specifically for detection of fuel gas leaks.**

**If a gas leak occurs you should be able to smell the fuel gas. Since Propane (LP) is heavier than air you should smell for the gas odor low to the floor. ANY GAS ODOR IS YOUR SIGNAL TO GO INTO IMMEDIATE ACTION!**

- Do not take any action that could ignite the fuel gas. Do not operate any electrical switches. Do not pull any power supply or extension cords. Do not light matches or any other source of flame. Do not use your telephone.
- Get everyone out of the building and away from the area immediately.
- Close all propane (LP) gas tank or cylinder fuel supply valves, or the main fuel supply valve located at the meter if you use natural gas.
- Propane (LP) gas is heavier than air and may settle in low areas. When you have reason to suspect a propane leak, keep out of all low areas.
- Use your neighbor's phone and call your fuel gas supplier and your fire department. Do not re-enter the building or area.
- Stay out of the building and away from the area until declared safe by the firefighters and your fuel gas supplier.
- FINALLY, let the fuel gas service person and the firefighters check for escaped gas. Have them air out the building and area before you return. Properly trained service people must repair any leaks, check for further leakages, and then relight the appliance for you.

#### ODOR FADING - NO ODOR DETECTED

- Some people cannot smell well. Some people cannot smell the odor of the man-made chemical added to propane (LP) or natural gas. You must determine if you can smell the odorant in these fuel gases.
- Learn to recognize the odor of propane (LP) gas and natural gas. Local propane (LP) gas dealers will be more than happy to give you a scratch and sniff pamphlet. Use it to become familiar with the fuel gas odor.
- Smoking can decrease your ability to smell. Being around an odor for a period of time can affect your sensitivity to that particular odor. Odors present in animal confinement buildings can mask fuel gas odor.
- **The odorant in propane (LP) gas and natural gas is colorless and the intensity of its odor can fade under some circumstances.**
- If there is an underground leak, the movement of gas through the soil can filter the odorant.
- Propane (LP) gas odor may differ in intensity at different levels. Since Propane (LP) gas is heavier than air, there may be more odor at lower levels.
- **Always be sensitive to the slightest gas odor.** If you continue to detect any gas odor, no matter how small, treat it as a serious leak. Immediately go into action as discussed previously.

#### ATTENTION - CRITICAL POINTS TO REMEMBER!

- Propane (LP) gas has a distinctive odor. Learn to recognize these odors. (Reference Fuel Gas Odor and Odor Fading sections above.)
- Even If you are not properly trained in the service and repair of the heater, ALWAYS be consciously aware of the odors of propane (LP) gas and natural gas.
- If you have not been properly trained in repair and service of propane (LP) gas then do not attempt to light heater, perform service or repairs, or make any adjustments to the heater on the propane (LP) gas fuel system.
- A periodic sniff test around the heater or at the heater's joints; i.e. hose, connections, etc., is a good safety practice under any conditions. If you smell even a small amount of gas, CONTACT YOUR FUEL GAS SUPPLIER IMMEDIATELY. DO NOT WAIT!

# Models

## 30-FAS/SPC-30, 55-F/SPC-55, 85-FAC/SPC-85, 125-F/SPC-125

### OPERATING INSTRUCTIONS

#### PREPARING FOR OPERATION

1. Check the heater for possible shipping damage. If any is found, *immediately* notify the factory.
2. Follow all of the "Precautions".
3. Connect the POL fitting of hose and regulator assembly to the propane cylinder by rotating the POL nut counterclockwise into the propane cylinder's valve outlet and securely tighten with a wrench.
4. Connect the hose to the heater by rotating the hose fitting clockwise.
5. Securely tighten all gas connections.
6. Open the cylinder's gas valve and check all gas connections with a soap and water solution. **DO NOT USE A FLAME.**
7. Connect power cord to well-grounded 115V, 60 Hz, 1Ø source of power.
8. When using an extension cord, make certain that it is a 3-wire (grounded) cord of proper wire size.

#### START

1. Before heater ignition, always allow heater fan (blower) to run for 20 seconds to purge fuel.
2. Slowly open the main valve at propane cylinder.
3. Depress the fuel valve button to light the 55-F/SPC-55, 85-FAC/SPC-85 and 125-F/SPC-125 models. On the 30-FAS/SPC-30 also push the ignition button until the heater lights.
4. After the heater lights, keep the gas valve button depressed for 15 seconds then release and the heater will continue to operate.
5. Adjust burn rate with ball valve to desired setting (55-F/SPC-55, 85-FAC/SPC-85 and 125-F/SPC-125 only).

#### STOP

1. Securely close valve on the propane cylinder.
2. Continue to operate heater until all fuel in the hose has burned.
3. Unplug the power cord.

#### RESTART AFTER SAFETY SHUTDOWN

1. Securely close valve at propane cylinder. Unplug heater.
2. Wait 5 minutes.
3. Restart following "Start" procedure.

#### MAINTENANCE AND STORAGE

1. The heater should be inspected before each use, and at least annually by a qualified person.
2. Before each use, check the soft "O" ring seat at the bullnose of the POL fitting. If the "O" ring is cut, scuffed, or otherwise damaged, replace it with part number 6681.
3. Turn off the gas at the LP-gas supply cylinder(s) when the heater is not in use.
4. When the heater is to be stored indoors, the connection between the LP-gas supply cylinder(s) and the heater must be disconnected and the cylinder(s) removed from the heater and stored out of doors and in accordance with Chapter 5 of the standard for Storage and Handling of Liquefied Petroleum Gases ANSI/NFPA 58 and CSA B149.1, Natural Gas and Propane Installation Code.

### SERVICING

A hazardous condition may result if a heater is used that has been modified or is not functioning properly. When the heater is working properly:

- \* The flame is contained within the heater.
- \* The flame is essentially blue with perhaps some yellow tipping.
- \* There is no strong disagreeable odor, eye burning or other physical discomfort.
- \* There is no smoke or soot internal or external to the heater.
- \* There are no unplanned or unexplained shut downs of the heater.

The parts lists and wiring diagram show the heater as it was constructed. Do not use a heater which is different from that shown. In this regard, use only the hose, regulator and cylinder connection fitting (called a POL fitting) supplied with the heater.

**IMPORTANT** Match the color stripe on the hangtag attached to the hose assembly with the color on the label located near the propane inlet fitting on the heater. Do not use alternates. For this heater, the regulator must be set as shown in "specifications". If there is any uncertainty about the regulator setting, have it checked.

A heater which is *not* working right must be repaired, but *only* by a trained, experienced service person. To find the service center closest to you, visit our website at [www.scheuco.com](http://www.scheuco.com) or call (888) 619-7060.

You may also obtain in-warranty or out-of-warranty service by taking the product to your local service center.

In-warranty products will be repaired with no charge for either parts or labor. Please include a brief statement indicating date, place of purchase, the nature of the problem and proof of purchase.

Out-of-warranty products will be repaired with a charge for parts and labor.

# Models 30-FAS/SPC-30, 55-F/SPC-55, 85-FAC/SPC-85, 125-F/SPC-125

## SIZE AND CAPACITY OF PROPANE CYLINDERS REQUIRED

The charts below show the approximate size of the cylinder required for these heaters. To use the chart:

1. Select the lowest air temperature expected (at the bottom of the chart).
2. Move straight up to time of operation desired (left side of chart).
3. Read the cylinder size required.

All heaters should have: full cylinders  
good air circulation  
no frost on cylinders

30,000 BTU/HR (11.8 kW)

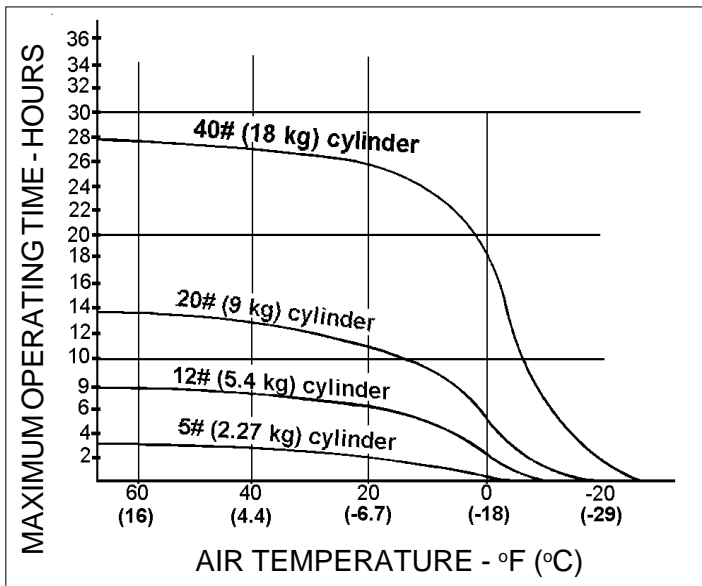

55,000 BTU/HR (16.1 kW)

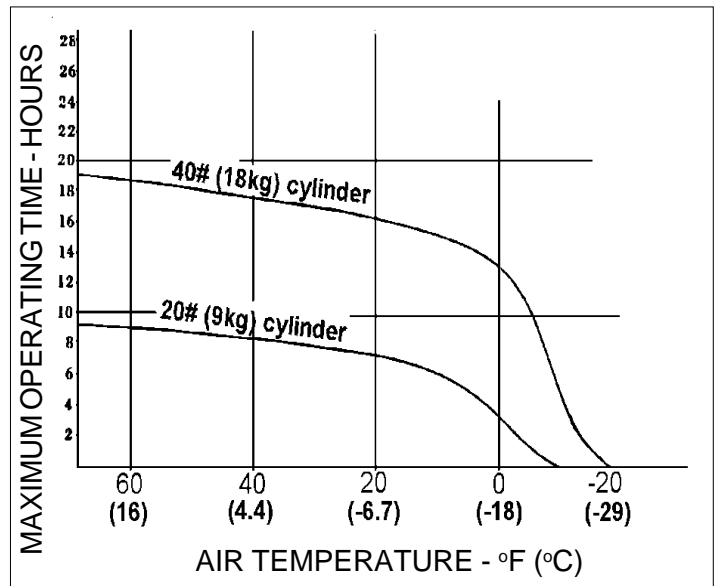

85,000 BTU/HR (33.4 kW)

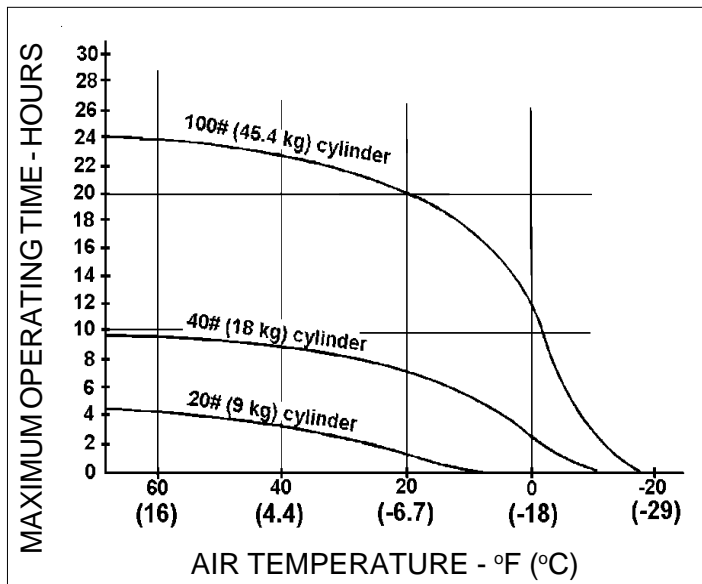

125,000 BTU/HR (49.1 kW)

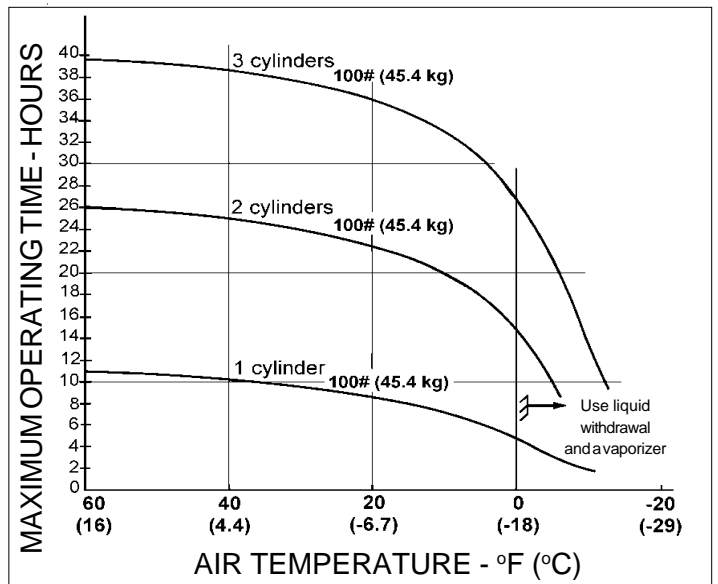

# Models 30-FAS/SPC-30, 55-F/SPC-55, 85-FAC/SPC-85, 125-F/SPC-125

## WIRING DIAGRAMS

**30-FAS/SPC-30**

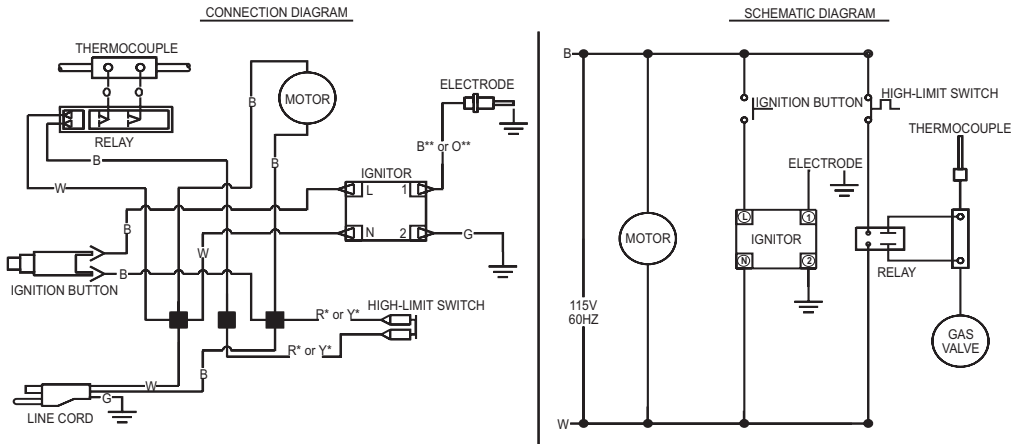

**SPC-55 85-FAC/SPC-85, 125-FAC/SPC-125**

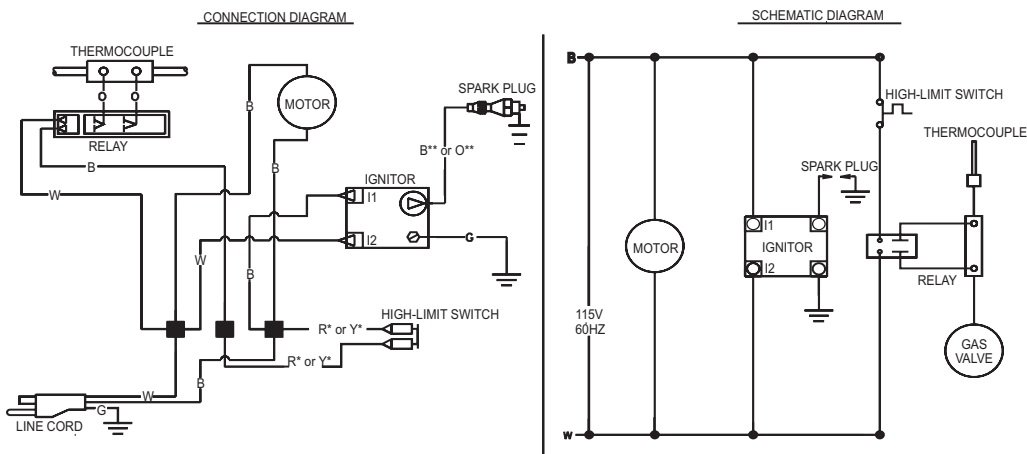

COLOR CODE		LEGEND	
B	BLACK	R	RED
BL	BLUE	Y	YEL
W	WHITE	O	ORG
G	GREEN		
		—	FEMALE CONN.
		○	RING CONN.
		■	TERMINAL BOARD

**NOTE:** IF ANY ORIGINAL WIRING AS SUPPLIED WITH THE HEATER MUST BE REPLACED, IT MUST BE REPLACED WITH TYPE AWG 105° C WIRE OR ITS EQUIVALENT EXCEPT AS INDICATED (\*TYPE SF 2-200, \*\*SGI-250°C)

### WIRING CHART

30-FAS/SPC-30					SPC-40,85-FAC/SPC-85,125-FAC/SPC-125				
Part No	Color	Length	From	To	Part No	Color	Length	From	To
1040	Black	6" (152mm)	Ignition Switch	T.B. Line	1040	Black	6" (152mm)	I1 (Ignitor)	T.B. Line
1040	Black	6" (152mm)	Ignition Switch	L (Ignitor)	1070	Orange	11" (279mm)	1 (Ignitor)	Spark Plug
1385	White	10" (253mm)	N (Ignitor)	T.B. Return	1041	White	4 1/2" (114mm)	I2 (Ignitor)	T.B. Return
1110	Green	4 1/2" (114mm)	2 (Ignitor)	Ground	1044	Yellow	16" (406mm)	High Limit	T.B. Middle
1370	Red	7" (177mm)	High Limit	T.B. Middle	1044	Yellow	16" (406mm)	High Limit	T.B. Line
1370	Red	7" (177mm)	High Limit	T.B. Line	1441	Black	5" (127mm)	Relay	T.B. Middle
1441	Black	5" (127mm)	Relay	T.B. Middle	1442	White	5" (127mm)	Relay	T.B. Return
1442	White	5" (127mm)	Relay	T.B. Return	1806	Orange	6" (152mm)	Relay	Thermocouple Junction Block
1806	Orange	6" (152mm)	Relay	Thermocouple Junction Block	1806	Orange	6" (152mm)	Relay	Thermocouple Junction Block
1806	Orange	6" (152mm)	Relay	Thermocouple Junction Block					





## 55-F / SPC-55 - PARTS

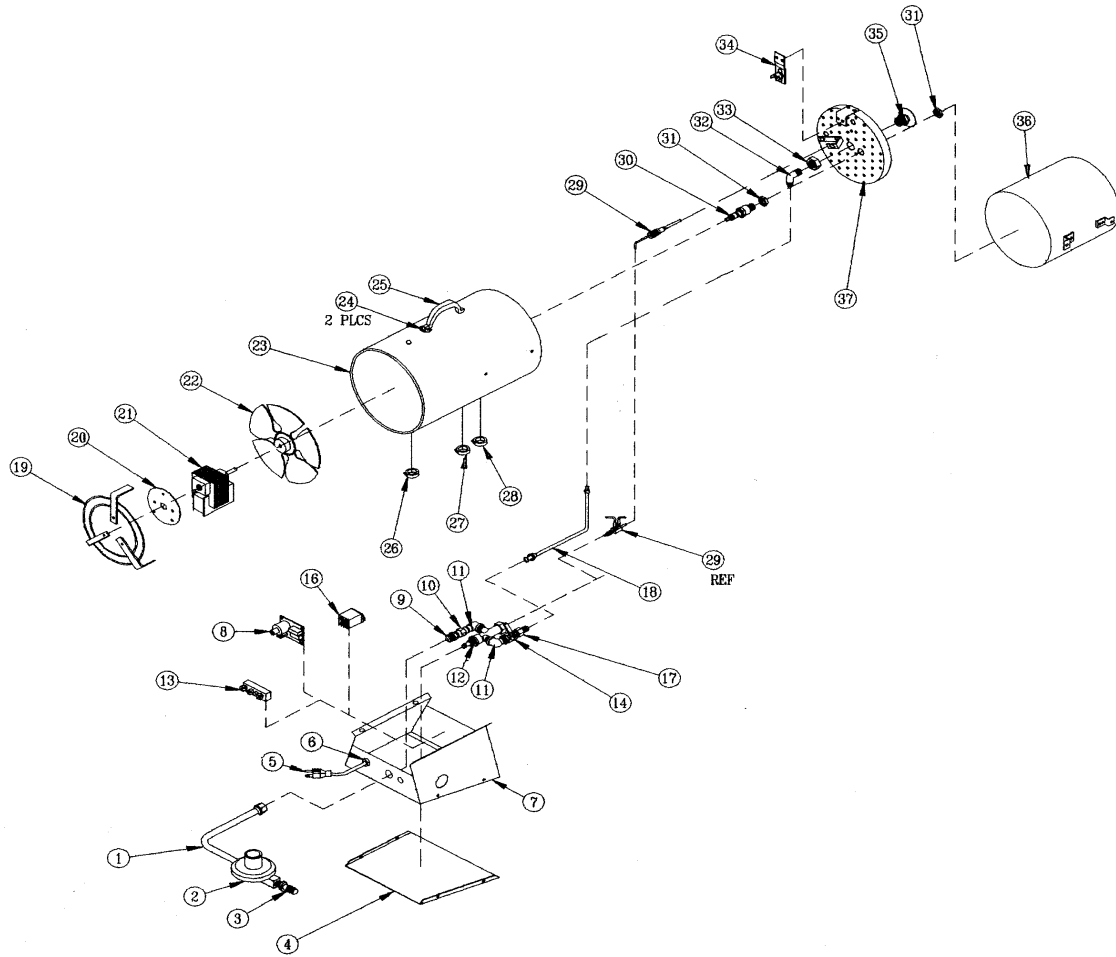

Item	55-F	SPC-55	Description	Qty	Item	55-F	SPC-55	Description	Qty.
1	6152	6152	Hose Assy, LP	1	27	6226	6226	Universal Bushing	1
2	6257	6257	Regulator 28" WC	1	28	6224	6224	Snap Bushing, 1/2	1
3	6433	6433	POL Excess Flow 1/4 MPT	1	29	6654	6654	Thermocouple 13" Lg w/J.B.	1
4	3955	3955	Panel, Bottom	1	30	1082	1082	Spark Plug	1
5	1036	1036	Power Cord Assy	1	31	3037	3037	Spark Plug Nut	2
6	6223	6223	Strain Relief Bushing	1	32	6121	6121	Ftg, Male Elbow	1
7	1904	1904	Control Box Assy	1	33	3038	3038	Orifice Nut Mtg	1
8	3275	3275	Ignitor HYLO 801	1	34	1751	1751	High Limit Control Assy	1
9	6127	6127	Ftg, Male Connector	1	35	2236	2236	Orifice Assy, LP	1
10	6133	6133	Ftg, Coupling	2	36	1651	1651	Middle Cylinder Assy	1
11	6265	6265	Ftg, Elbow Street	2	37	1931	1931	Flame Holder Assy	1
12	7285	7285	Thermoelectric Valve	1	*	8784	8784	Manual, Operating Instructions/Parts List	1
13	6641	6641	Terminal Board	1	*	8633	8633	Label, Model	1
14	7431	7431	Ball Valve	1	*	7783	7783	Label, Operating Instructions	1
*	6189	6189	Terminal "Y"	2	*	7781	7781	Label, BTU Rating	2
16	1811	1811	Relay Assembly	1	*	6374	6374	Label, Electrical Grounding	1
17	3141	3141	Ftg., Female Connector	1	*	7651	7651	Label, Fuel	1
18	1935	1935	Fuel Tube Assy	1	*	7503	7503	Label, Wiring Diagram	1
19	1654	1654	Motor Grille Assy	1	*	6383	8362	Label, Logo	2
20	3676	3676	Brkt, Motor Mounting	1	*	6373	6373	Label, Fan Rotation	1
21	1652	1652	Motor Assy	1	*	1667	1667	Hose & Regulator Assembly	1
22	6086	6086	Fan, 7"	1	*	8203	8203	Label Hang Tag, LP	1
23	2245	2246	Outer Cylinder	1	*	7709	7709	Label, Fuel	1
24	7094	7094	Clip Handle Mounting	2	*	7704	7704	Label Warning	1
25	7095	7095	Handle	1	*Not shown on exploded view				
26	6225	6225	Snap Bushing, 5/8	1					

# 85-FAC / SPC-85 - PARTS

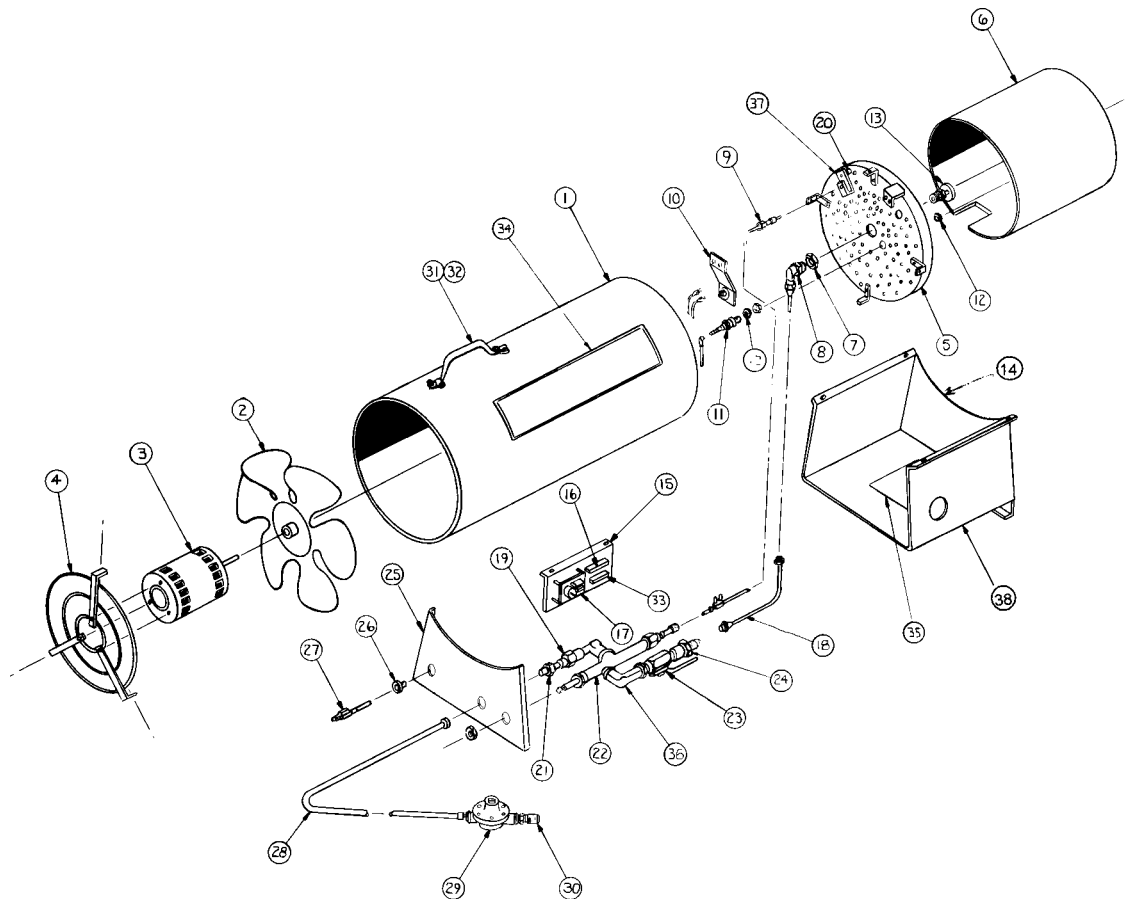

Item	SPC-85	85-FAC	Description	Qty.	Item	SPC-85	85FAC	Description	Qty.
1	1670	1730	Cylinder, Outer Assembly	1	26	6223	6223	Strain Relief Bushing	1
2	6086	6086	Fan, 7 inch	1	27	1036	1036	Power Cord	1
3	1551	1551	Motor Assembly, 80-FAS	1	28	6152	6152	Hose Assembly	1
4	1671	1671	Grille, Motor Mtg./Inlet Assy. 85	1	29	6257	6257	Regulator, 28" W.C. (6.97 kPa)	1
5	1750	1750	Flame Holder Assembly	1	30	6433	6433	POL Excess Flow	1
6	1674	1674	Cylinder, Middle Assembly	1	31	7094	7094	Clip Handle Mounting, 3 pcs.	2
7	3038	3038	Nut, Orifice Mounting 3/4-16	1	32	7095	7095	Handle, 3 pcs	1
8	7433	7433	Fitting, Male Elbow	1	33	1811	1811	Relay	1
9	6654	6654	Thermocouple	1	34	8362	6383	Label, Logo	2
10	1751	1751	High Limit Control Assembly	1	35	7503	7503	Label, Wiring	1
11	1083	1083	Spark Plug, 1/8 Gap	1	36	6265	6265	Fitting, Elbow	2
12	3037	3037	Nut-Spark Plug	3	37	3036	3036	Bracket, TC	1
13	1673	1673	Orifice Assembly	1	38	3775	3775	Side Panel	1
14	1752A	1752A	Control Box Assembly	1	*	8784	8784	Manual, Operating Instructions/Parts List	1
15	3044	3044	Ignition Relay Bracket	1	*	8507	8507	Label, Model	1
16	6641	6641	Terminal Board	1	*	8508	8508	Label, Operating Instructions	1
17	3275	3275	Spark Ignition, 115V	1	*	7432	7432	Label, BTU Rating	2
18	1668	1668	Fuel Tube Assembly	1	*	6374	6374	Label, Electrical Grounding	1
19	6133	6133	Fitting, Coupling	1	*	7709	7709	Label, Fuel Ignition	1
20	3787	3787	Spacer, TC Bracket	1	*	8203	8203	Label, Hang Tag, LP	1
21	6127	6127	Fitting, Male Connector	1	*	7704	7704	Label, Warning	1
22	7285	7285	TE Valve	1	*	6373	6373	Label, Fan	1
23	7404	7404	Ball Valve, Variable Rate	1					
24	7405	7405	Fitting, Female Connector	1					
25	3690	3690	Control Panel Assembly	1					
								*Not shown on exploded view	

# 125-F / SPC-125 - PARTS

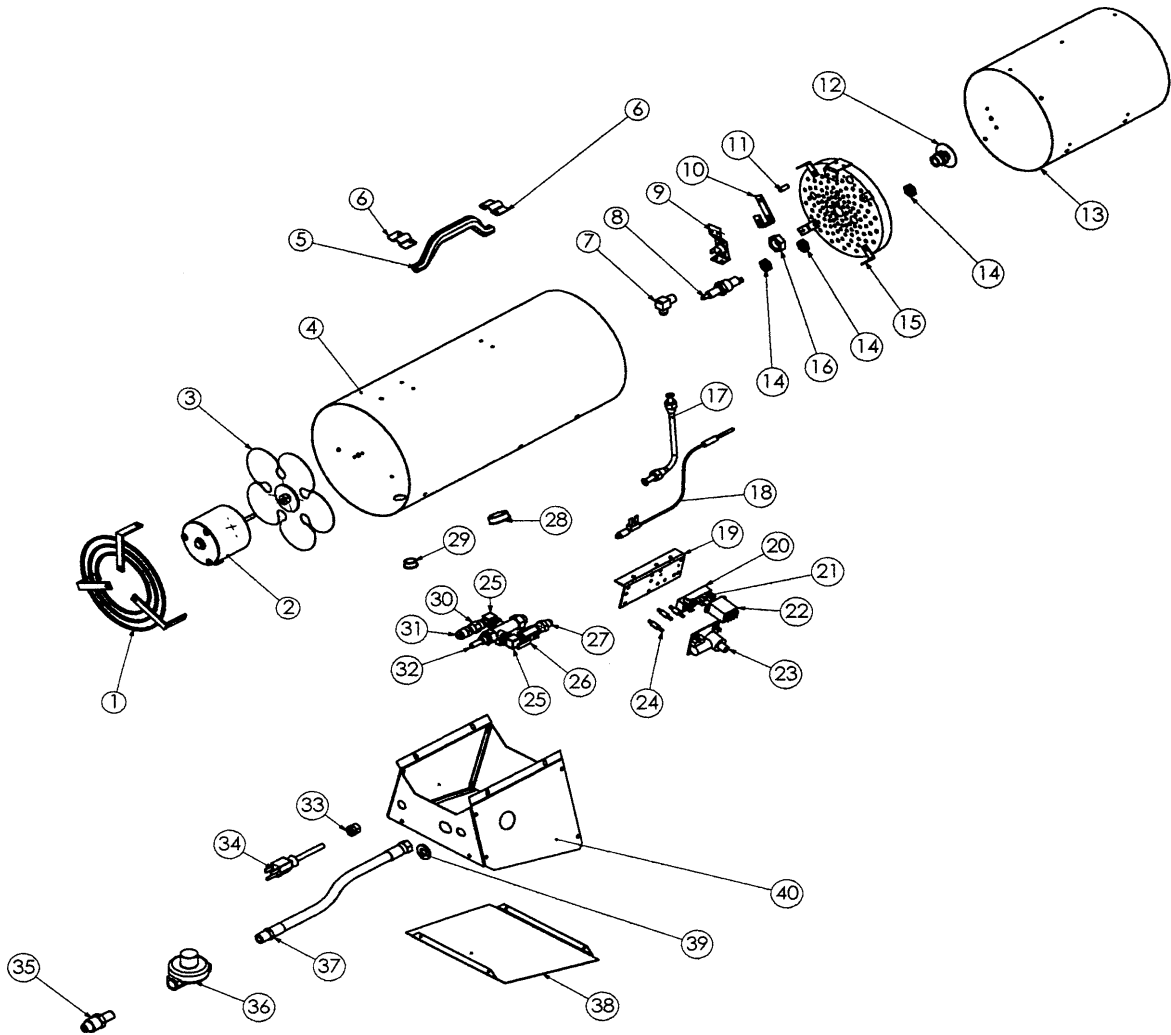

Item SPC-125 125-F	Description	Qty.	Item SPC-125 125-F	Description	Qty.
1 1671	1671 Grille Assembly	1	28 6227	6227 Snap Bushing, 1 1/4 Nylon	1
2 1551	1551 Motor Assembly	1	29 7158	7158 Snap Bushing, 3/4 Nylon	1
3 7898	7898 Fan, 8" (203.2mm)	1	30 6133	6133 Fitting, Coupling	1
4 1998	1999 Cylinder, Outer Shell Assembly	1	31 6127	6127 Fitting, Male Connector	1
5 7095	7095 Handle	1	32 7285	7285 Valve, Thermoelectric	1
6 7094	7094 Clip Handle Mounting	2	33 6223	6223 Bushing, Strain Relief	1
7 7433	7433 Fitting, Male Elbow	1	34 1036	1036 Power Cord	1
8 1083	1083 Spark Plug, 1/8 (3.18mm) Gap	1	35 6433	6433 POL Excess Flow (6.97 kPa)	1
9 2003	2003 Control, High Limit Switch Assy.	1	36 6257	6257 Regulator, 28" W.C.	1
10 3036	3036 Bracket, Thermocouple	1	37 6152	6152 Hose Assembly, LP	2
11 3787	3787 Spacer, Thermocouple	1	38 4019	4019 Bottom Control Box	1
12 2002	2002 Orifice, LP Assembly	1	39 7843	7843 Washer, Flat	1
13 2001	2001 Cylinder, Middle Assembly	1	40 2005	2005 Control Box Assembly	1
14 3037	3037 Nut, Spark Plug	3	* 6374	6374 Label, Electrical Ground	1
15 2004	2004 Flame Holder Assembly	1	* 6373	6373 Label, Fan	1
16 3038	3038 Nut, Orifice Mounting	1	* 8362	6383 Label, Logo	2
17 1668	1668 Fuel Tube Assembly	1	* 8784	8784 Label, Operating Instructions	1
18 6654	6654 Thermocouple	1	* 7709	7709 Label, Ignition/Fuel	1
19 3044	3044 Bracket Ignition Relay	1	* 8371	8371 Label, BTU Rating	2
20 6641	6641 Terminal Board	1	* 7503	7503 Label, Wiring	1
21 6065	6065 Spacer, Steel	1	* 8510	8510 Label, Model	1
22 1811	1811 Relay Assembly	1	* 8653	8653 Manual, Operating Instructions/Parts List	1
23 3275	3275 Ignitor, Hi-Lo 801 Mini	1	* 8203	8203 Label, Hang Tag, LP	1
24 6079	6079 Spacer, PC Standoff Nylon	3	* 7704	7704 Label, Warning	1
25 6265	6265 Fitting, Elbow Street	2			
26 7897	7897 Ball Valve, Variable Rate	1			
27 7405	7405 Fitting, Female Connector	1			

\*Not shown on exploded view

# Models

## 30-FAS/SPC-30, 55-F/SPC-55, 85-FAC/SPC-85, 125-F/SPC-125

### WARRANTY

We are pleased that you have selected our product and take this opportunity to assure you that qualified service facilities are available if required. With the cooperation of independent dealers, a nationwide network of authorized servicing dealers is available for your servicing requirements.

Should your product require servicing, read the section of the manual entitled "Servicing".

Who gets the warranty? The warranty is limited to the consumer who originally purchases the product.

What is covered? This limited warranty covers all imperfections in workmanship and material.

What is not covered? This limited warranty does not cover damage resulting from accident, misuse or abuse, lack of proper maintenance, affixing of any attachments not provided with the products, or loss of parts. IN NO EVENT SHALL SCHEU PRODUCTS COMPANY BE LIABLE FOR ANY SPECIAL, INCIDENTAL OR CONSEQUENTIAL DAMAGES NOR FOR ANY DAMAGES RESULTING FROM MISUSE OR MODIFICATION OF THIS PRODUCT.

Registering this heater within 10 days of date of purchase ensures the buyer the protection as stated on our limited warranty form.

#### LIMITED WARRANTY

The company warrants this product to be free from imperfections in material or workmanship, under normal and proper use in accordance with instructions of The Company, for a period of one year from the date of delivery to the buyer. The Company, at its option, will repair or replace (f.o.b. factory, California) products returned by the buyer to the factory, California, transportation prepaid within said one year period and found by the Company to have imperfections in material or workmanship.

If a part is damaged or missing, simply e-mail us at [php@scheuco.com](mailto:php@scheuco.com), visit our website at [scheuco.com](http://scheuco.com), or call our Technical Support Department at (888) 619-7060.

Address any Warranty Claims to the Customer Service Department, Scheu Products Company, Incorporated, P.O. Box 250, Upland, California 91785, or e-mail us at [php@scheuco.com](mailto:php@scheuco.com). Include your name, address and telephone number and include details concerning the claim. Also, supply us with the purchase date and the name and address of the dealer from whom you purchased our product.

The foregoing is the full extent of the responsibility of the Company. There are no other warranties, express or implied. Specifically there is no warranty of fitness for a particular purpose and there is no warranty of merchantability. In no event shall the Company be liable for delay caused by imperfections, for consequential damages, or for any charges of the expense of any nature incurred without its written consent. The cost of repair or replacement shall be the exclusive remedy for any breach of warranty. There is no warranty against infringement of

the like and no implied warranty arising from course of dealing or usage of trade. This warranty will not apply to any product which has been repaired or altered outside of the California factory in any respect which in our judgment affects its condition or operation.

Some states do not allow the exclusion or limitation of incidental or consequential damages, so the above limitation or exclusion may not apply to you. This Warranty gives you specific legal rights, and you may have other rights which vary from state to state.

### SERVICE CENTERS

Scheu Products Company has over 1,000 service centers throughout North America. Call (888) 619-7060 or e-mail [php@scheuco.com](mailto:php@scheuco.com) to request the service center nearest you. Include the Make and model of your heater in any e-mails.

### INSTRUCTIONS FOR ORDERING PARTS

We recommend that only parts supplied by the manufacturer be used on this unit. A locally purchased part may appear to be identical, although in reality it might endanger the heater or the persons operating the heater.

The heater should be serviced only by a trained, experienced service person.

Read the section on "Servicing" before ordering parts.

For parts orders, call 888-619-7060 or e-mail us at [php@scheuco.com](mailto:php@scheuco.com). Please have the model number of your heater and the replacement part number when placing your order.